

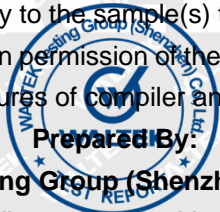


TEST REPORT

Reference No..... : WTF21X10112193W-3
 Manufacturer : Mid Ocean Brands B.V.
 Address : 7/F., Kings Tower, 111 King Lam Street, Cheung Sha Wan, Kowloon, Hong Kong
 Factory : 114889
 Product : Hub wireless charger penholder
 Test Model : MO6351
 Standards : EN 55032:2015+A11:2020; EN 55035:2017+A11:2020
 EN IEC 61000-3-2:2019; EN 61000-3-3:2013+A1:2019
 ETSI EN 301 489-1 V2.2.3 (2019-11)
 ETSI EN 301 489-3 V2.1.1 (2019-03)
 Date of Receipt sample : Oct. 21, 2021
 Date of Test..... : Oct. 21, 2021 to Jan. 14,2022
 Date of Issue : Jan. 14,2022
 Test Result..... : Pass

Remarks:

The results shown in this test report refer only to the sample(s) tested, this test report cannot be reproduced, except in full, without prior written permission of the company. The report would be invalid without specific stamp of test institute and the signatures of compiler and approver.



Prepared By:

Waltek Testing Group (Shenzhen) Co., Ltd.

Address: 1/F., Room 101, Building 1, Hongwei Industrial Park, Liuxian 2nd Road,
Block 70 Bao'an District, Shenzhen, Guangdong, China

Tel.: +86-755-33663308

Fax.: +86-755-33663309

Tested by:

Reviewed By:

Approved & Authorized By:

Mike Shi

Jason Su

Silin Chen

Mike Shi / Project Engineer

Jason Su / RF Manager

Silin Chen / Manager



TABLE OF CONTENTS

1. GENERAL INFORMATION.....	5
1.1 PRODUCT DESCRIPTION FOR EQUIPMENT UNDER TEST (EUT).....	5
1.2 TEST STANDARDS.....	6
1.3 TEST METHODOLOGY.....	6
1.4 TEST FACILITY.....	6
1.5 EUT SETUP AND OPERATION MODE.....	7
1.6 PERFORMANCE CRITERIA FOR EMS.....	8
1.7 MEASUREMENT UNCERTAINTY.....	10
1.8 TEST EQUIPMENT LIST AND DETAILS.....	11
2. SUMMARY OF TEST RESULTS.....	13
3. CONDUCTED EMISSIONS.....	14
3.1 TEST PROCEDURE.....	14
3.2 BASIC TEST SETUP BLOCK DIAGRAM.....	14
3.3 ENVIRONMENTAL CONDITIONS.....	14
3.4 CONDUCTED EMISSIONS TEST DATA.....	14
4. RADIATED EMISSIONS.....	19
4.2 TEST PROCEDURE.....	19
4.2 CORRECTED AMPLITUDE & MARGIN CALCULATION.....	19
4.3 ENVIRONMENTAL CONDITIONS.....	20
4.4 SUMMARY OF TEST RESULTS/PLOTS.....	20
5. HARMONIC CURRENT EMISSIONS.....	24
5.1 TEST PROCEDURE.....	24
5.2 TEST SETUP BLOCK DIAGRAM.....	24
5.3 TEST STANDARDS.....	24
5.4 ENVIRONMENTAL CONDITIONS.....	24
5.5 HARMONIC CURRENT EMISSIONS TEST DATA.....	24
6. VOLTAGE FLUCTUATION AND FLICKER.....	25
6.1 TEST PROCEDURE.....	25
6.2 TEST SETUP BLOCK DIAGRAM.....	25
6.3 TEST STANDARDS.....	25
6.4 ENVIRONMENTAL CONDITIONS.....	25
6.5 VOLTAGE FLUCTUATION AND FLICKER TEST DATA.....	25
7. ELECTROSTATIC DISCHARGE (ESD).....	27
7.1 TEST PROCEDURE.....	27
7.2 TEST SETUP BLOCK DIAGRAM.....	27
7.3 TEST PERFORMANCE.....	27
7.4 ENVIRONMENTAL CONDITIONS.....	27
7.5 ELECTROSTATIC DISCHARGE IMMUNITY TEST DATA.....	27
8. RADIO FREQUENCY ELECTROMAGNETIC FIELD (R/S).....	29
8.1 TEST PROCEDURE.....	29
8.2 TEST SETUP BLOCK DIAGRAM.....	29
8.3 TEST PERFORMANCE.....	29
8.4 ENVIRONMENTAL CONDITIONS.....	29
8.5 CONTINUOUS RADIATED DISTURBANCES TEST DATA.....	29
9. FAST TRANSIENTS, COMMON MODE (EFT).....	31
9.1 TEST PROCEDURE.....	31
9.2 TEST SETUP BLOCK DIAGRAM.....	31
9.3 TEST PERFORMANCE.....	31
9.4 ENVIRONMENTAL CONDITIONS.....	31
9.5 ELECTRICAL FAST TRANSIENTS TEST DATA.....	31



10. SURGES	33
10.1 TEST PROCEDURE.....	33
10.2 TEST SETUP BLOCK DIAGRAM.....	33
10.3 TEST PERFORMANCE.....	33
10.4 ENVIRONMENTAL CONDITIONS.....	33
10.5 SURGE TEST DATA.....	33
11. RADIO FREQUENCY, COMMON MODE (C/S)	35
11.1 TEST PROCEDURE.....	35
11.2 TEST SETUP BLOCK DIAGRAM.....	35
11.3 TEST PERFORMANCE.....	35
11.4 ENVIRONMENTAL CONDITIONS.....	35
11.5 CONTINUOUS CONDUCTED DISTURBANCES TEST DATA.....	35
12. VOLTAGE DIPS AND INTERRUPTIONS	37
12.1 TEST PROCEDURE.....	37
12.2 TEST SETUP BLOCK DIAGRAM.....	37
12.3 TEST PERFORMANCE.....	37
12.4 ENVIRONMENTAL CONDITIONS.....	37
12.5 VOLTAGE DIPS AND INTERRUPTIONS TEST DATA.....	37
EXHIBIT 1 - EUT PHOTOGRAPHS	38
EXHIBIT 2 - TEST SETUP PHOTOGRAPHS	39

WALTEK



Report version

Version No.	Date of issue	Description
Rev.00	Jan. 14,2022	Original
/	/	/

WALTEK



1. GENERAL INFORMATION

1.1 Product Description for Equipment Under Test (EUT)

Client Information

Manufacturer: Mid Ocean Brands B.V.
 Address of manufacturer: 7/F., Kings Tower, 111 King Lam Street, Cheung Sha Wan,
 Kowloon, Hong Kong

Factory: 114889

General Description of EUT	
Product Name:	Hub wireless charger penholder
Trade Name:	/
Model No.:	MO6351
Adding Model(s):	/
Rate Power:	Wireless output:5W/7.5W/10W
Software Version:	R9303-0080-V2.1
Hardware Version:	F5-10W-V1.0
<i>Note: The test data is gathered from a production sample, provided by the manufacturer.</i>	

Technical Characteristics of EUT	
EN 303417	
Frequency Range:	110-205kHz
Radiated H-Field:	42.54dBuA/m(@3m)
Type of Antenna:	Coil Antenna
<i>Note: The Antenna Gain is provided by the customer.</i>	



1.2 Test Standards

The tests were performed according to following standards:

EN 55032:2015+A11:2020: Electromagnetic compatibility of multimedia equipment - Emission requirements.

EN 55035:2017+A11:2020: Electromagnetic compatibility of multimedia equipment - Immunity requirements.

EN IEC 61000-3-2:2019: Electromagnetic compatibility (EMC) -- Part 3-2: Limits - Limits for harmonic current emissions (equipment input current up to and including 16 A per phase).

EN 61000-3-3:2013+A1:2019: Electromagnetic compatibility (EMC) -- Part 3-3: Limits - Limitation of voltage changes, voltage fluctuations and flicker in public low-voltage supply systems, for equipment with rated current ≤ 16 A per phase and not subject to conditional connection.

ETSI EN 301 489-1 V2.2.3 (2019-11): Electromagnetic Compatibility (EMC) standard for radio equipment and services; Part 1: Common technical requirements; Harmonised Standard for Electromagnetic Compatibility.

ETSI EN 301 489-3 V2.1.1 (2019-03): Electromagnetic Compatibility (EMC) standard for radio equipment and services; Part 3: Specific conditions for Short-Range Devices (SRD) operating on frequencies between 9 kHz and 246 GHz; Harmonised Standard covering the essential requirements of article 3.1(b) of Directive 2014/53/EU.

Maintenance of compliance is the responsibility of the manufacturer. Any modification of the product maybe which result in lowering the emission/immunity should be checked to ensure compliance has been maintained.

1.3 Test Methodology

All measurements contained in this report were conducted with the standard ETSI EN 301489-1, Electromagnetic compatibility and Radio spectrum Matters (ERM); Electromagnetic Compatibility (EMC) standard for radio equipment and services; Part 1: Common technical requirements.

1.4 Test Facility

FCC – Registration No.: 125990

Waltek Testing Group (Shenzhen) Co., Ltd. Laboratory has been recognized to perform compliance testing on equipment subject to the Commissions Declaration Of Conformity (DOC). The Designation Number is CN5010, and Test Firm Registration Number is 125990.

Industry Canada (IC) Registration No.: 11464A

The 3m Semi-anechoic chamber of Waltek Testing Group (Shenzhen) Co., Ltd. has been registered by Certification and Engineering Bureau of Industry Canada for radio equipment testing with Registration No.: 11464A.



1.5 EUT Setup and Operation Mode

The equipment under test (EUT) was configured to measure its highest possible emission/immunity level. The test modes were adapted according to the operation manual for use, more detailed description as follows:

Test Mode List		
Test Mode	Description	Remark
TM1	Wireless Charging & USB Output	Connect to the AC230V/50Hz ;Wireless Output 5W,USB port full load
TM2	Wireless Charging & USB Output	Connect to the AC230V/50Hz ;Wireless Output 10W and USB output 5W
TM3	Wireless Charging	TT,CT for EMS testing

EUT Cable List and Details			
Cable Description	Length (m)	Shielded/Unshielded	With / Without Ferrite
USB Cable	1.0	Unshielded	Without Ferrite

Special Cable List and Details			
Cable Description	Length (m)	Shielded/Unshielded	With / Without Ferrite
/	/	/	/

Auxiliary Equipment List and Details			
Description	Manufacturer	Model	Serial Number
Adapter	/	A138A-120150U-CN2	/



1.6 Performance Criteria for EMS

➤ EN 301 489-3, The performance criteria are:

In the table below:

- performance criterion A applies for immunity tests with phenomena of a continuous nature;
- performance criterion B applies for immunity tests with phenomena of a transient nature.

NOTE: Whether a phenomenon is considered transient, continuous or otherwise is indicated in the test procedures for the phenomenon in ETSI EN 301 489-1 [1], clause 9.

Table 2: Performance Requirements

Criterion	During test	After test
A	Operate as intended No loss of function No unintentional responses	Operate as intended No loss of function No degradation of performance No loss of stored data or user programmable functions
B	May show loss of function No unintentional responses	Operate as intended Lost function(s) shall be self-recoverable No degradation of performance No loss of stored data or user programmable functions

Where "operate as intended" or "no loss of function" is specified, the EUT shall demonstrate correct functioning as described in clause 5.

Where the EUT has more than one mode of operation (see clause 4.5.2), an unplanned transition from one mode to another is considered as an unintentional response. The EUT shall be tested in sufficient modes to confirm there are no such unintentional responses.



➤ **EN 55035, The performance criteria are:**

- A. The apparatus shall continue to operate as intended during and after the test. The manufacturer specifies some minimum performance level. The performance level may be specified by the manufacturer as a permissible loss of performance.
- B. The apparatus shall continue to operate as intended after the test. This indicates that the EUT does not need to function at normal performance levels during the test, but must recover. Again some minimal performance is defined by the manufacture. No change in operating state or loss or data is permitted.
- C. Temporary loss of function is allowed. Operation of the EUT may stop as long as it is either automatically reset or can be manually restored by operation of the controls.

WALTEK



1.7 Measurement Uncertainty

Measurement uncertainty	
Parameter	Uncertainty
Uncertainty for Radiated Emission in 3m chamber	@30-200MHz $\pm 4.52\text{dB}$ @0.2-1GHz $\pm 5.56\text{dB}$ @1-6GHz $\pm 3.84\text{dB}$ @6-18GHz $\pm 3.92\text{dB}$
Uncertainty for Conducted Emission	@9-150kHz $\pm 3.74\text{dB}$ @0.15-30MHz $\pm 3.34\text{dB}$
Uncertainty for Harmonic test	3.26%
Uncertainty for Flicker test	4.76%
Uncertainty for RS test	21%, k=2
Uncertainty for CS test	29%, k=2
Uncertainty for ESD test	The immunity measurement system uncertainty is within standard requirement and is based on a standard uncertainty multiplied by a coverage factor k=2, providing a level of confidence of approximately 95%.
Uncertainty for EFT test	
Uncertainty for Surges test	
Uncertainty for Voltage Dips, Voltage Variations and Short Interruptions Test	
Uncertainty for PFMF test	



1.8 Test Equipment List and Details

Description	Manufacturer	Model	Serial Number	Cal Date	Due Date
<input checked="" type="checkbox"/> Chamber A: Below 1GHz					
Spectrum Analyzer	Rohde & Schwarz	FSP30	836079/035	2021-03-30	2022-03-29
EMI Test Receiver	Rohde & Schwarz	ESVB	825471/005	2021-04-12	2022-04-11
Amplifier	Agilent	8447F	3113A06717	2022-01-07	2023-01-06
Loop Antenna	Schwarz beck	FMZB 1516	9773	2021-03-20	2023-03-19
Trilog Broadband Antenna	Schwarz beck	VULB9163	9163-333	2021-03-20	2023-03-19
<input checked="" type="checkbox"/> Chamber A: Above 1GHz					
Spectrum Analyzer	Rohde & Schwarz	FSP30	836079/035	2021-03-27	2022-03-26
Spectrum Analyzer	Rohde & Schwarz	FSP40	100612	2021-03-27	2022-03-26
EMI Test Receiver	Rohde & Schwarz	ESVB	825471/005	2021-04-12	2022-04-11
Amplifier	C&D	PAP-1G18	2002	2022-01-07	2023-01-06
Horn Antenna	ETS	3117	00086197	2021-03-19	2023-03-18
Horn Antenna	Schwarzbeck	BBHA 9170	BBHA9170582	2021-03-19	2023-03-18
Pre-amplifier	Direction Systems Inc.	PAP-2640	14145-14153	2021-04-27	2022-04-26
Power Limiter	Agilent	N9356B	MY45450376	2021-03-27	2022-03-26
<input type="checkbox"/> Chamber B: Below 1GHz					
Trilog Broadband Antenna	Schwarz beck	VULB9163(B)	9163-635	2021-04-09	2023-04-08
Amplifier	Agilent	8447D	2944A10179	2021-04-12	2022-04-11
EMI Test Receiver	Rohde & Schwarz	ESPI	101391	2021-05-06	2022-05-05
<input type="checkbox"/> Chamber C: Below 1GHz					
EMI Test Receiver	Rohde & Schwarz	ESIB 26	100401	2022-01-07	2023-01-06
Trilog Broadband Antenna	Schwarz beck	VULB 9168	1194	2021-05-28	2023-05-27
Amplifier	HP	8447F	2944A03869	2021-04-15	2022-04-14
<input checked="" type="checkbox"/> Conducted Room 1#					
EMI Test Receiver	Rohde & Schwarz	ESPI	101611	2021-04-12	2022-04-11
Pulse Limiter	Rohde & Schwarz	ESH3-Z2	100911	2021-04-15	2022-04-14
AC LISN	Schwarz beck	NSLK8126	8126-224	2021-04-12	2022-04-11
8-WIRE LISN	Schwarz beck	8158	CAT3-8158-0059	2021-04-12	2022-04-11
8-WIRE LISN	Schwarz beck	8158	CAT5-8158-0117	2021-04-12	2022-04-11
<input type="checkbox"/> Conducted Room 2#					
EMI Test Receiver	Rohde & Schwarz	ESPI	10129	2021-04-12	2022-04-11
LISN	Rohde & Schwarz	ENV 216	100097	2021-04-12	2022-04-11
EMF					
VDH Test Head	AFJ	VDH 30	SC022Z	2021-04-15	2022-04-14



3 Loop Antenna					
Loop Antenna	ZHINAN	ZN30401	19037	2021-04-26	2023-04-25
Clamp					
Clamp	Luthi	MDS21	3809	2021-04-16	2022-04-15
PFMF					
PMF Generator	LIONCEL	PMF-801C-C	0171101	2021-04-12	2022-04-11
PMF Antenna	LIONCEL	PMF-801C-A	0180302	2021-04-12	2022-04-11
Instantaneous PMF Generator Module	LIONCEL	PMF-801C-T	0171001	2021-04-12	2022-04-11
H/F					
Digital Power Analyzer	California Instrument	CTS	72831	2021-04-12	2022-04-11
Power Source	California Instrument	5001IX-CTS-400	25965	2021-04-12	2022-04-11
ESD					
ESD Generator	LIONCEL	ESD-203B	0170901	2021-04-16	2022-04-15
EFT/SURGE/DIPS					
Transient 2000	EMC PARTNER	TRA2000	863	2021-04-12	2022-04-11
Couple Clamp	EMC PARTNER	CN-EFT1000	513	2021-04-12	2022-04-11
CS					
CONDUCTED IMMUNITY TEST SYSTEM	FRANKONIA	CIT-10/75	126B1247/2013	2022-01-07	2023-01-06
Attenuator	EMTEST	MA-5100/6BF2	1009	2021-03-30	2022-03-29
CDN	Luthi	L-801M2/M3	2665	2021-04-12	2022-04-11
EM Injection Clamp	FCC	F-203I-23mm	91536	2021-04-12	2022-04-11
RS					
Signal Generator	HP	8688B	3438A00604	2021-03-30	2022-03-29
Power Meter	KEITHLEY	3500	1162591	2021-03-27	2022-03-26
Power Meter	KEITHLEY	3500	1121428	2021-03-27	2022-03-26
RF Power Amplifier	MicoTop	MPA-80-1000-250	MPA1906239	2021-03-27	2022-03-26
RF Power Amplifier	MicoTop	MPA-80-1000-100	MPA1906238	2021-03-27	2022-03-26
Antenna	SCHWARZBECK	STLP 9129	9129 114	N/A	N/A

Software List			
Description	Manufacturer	Model	Version
EMI Test Software (Radiated Emission)*	Farad	EZ-EMC	RA-03A1
EMI Test Software (Conducted Emission)*	Farad	EZ-EMC	RA-03A1

*Remark: indicates software version used in the compliance certification testing.



2. SUMMARY OF TEST RESULTS

Standards	Reference	Description of Test Item	Result
ETSI EN 301 489-1	8.2	Radiated Emissions	Pass
	8.3	Conducted Emissions for DC Power Port	N/A
	8.4	Conducted Emissions for AC Power Port	Pass
	8.5	Harmonic Current Emissions	N/A
	8.6	Voltage Fluctuations and Flicker	Pass
	8.7	Telecommunication Ports	N/A
	9.2	Radio Frequency Electromagnetic Field	Pass
	9.3	Electrostatic Discharge	Pass
	9.4	Fast Transients, Common Mode	Pass
	9.5	Radio Frequency, Common Mode	Pass
	9.6	Transient and Surges in the Vehicular Environment	N/A
	9.7	Voltage Dips and Interruptions	Pass
	9.8	Surges	Pass

Pass: The EUT complies with the essential requirements in the standard.

Fail: The EUT does not comply with the essential requirements in the standard.

N/A: Not applicable.

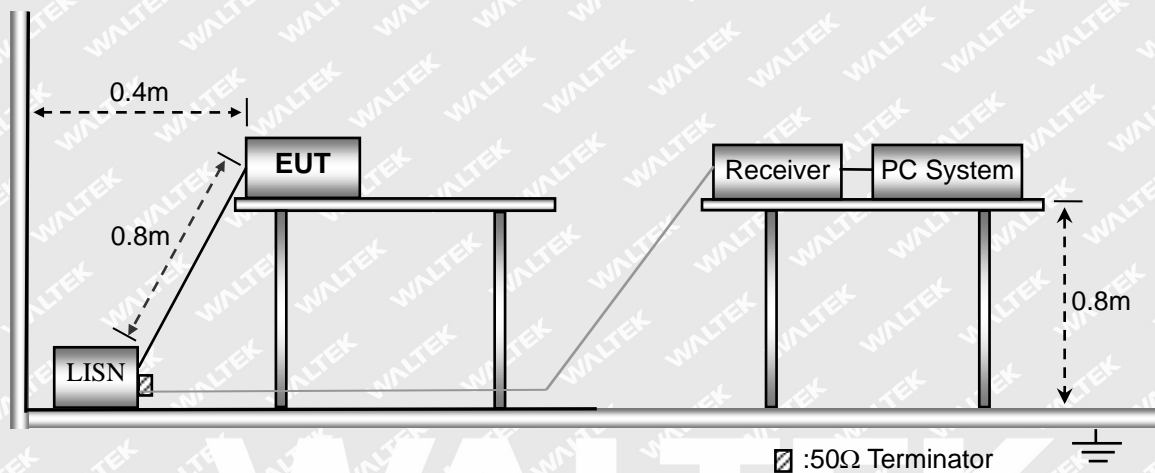


3. Conducted Emissions

3.1 Test Procedure

Test is conducting under the description of EN55032 Information technology equipment - Radio disturbance characteristics - Limits and methods of measurement.

3.2 Basic Test Setup Block Diagram



3.3 Environmental Conditions

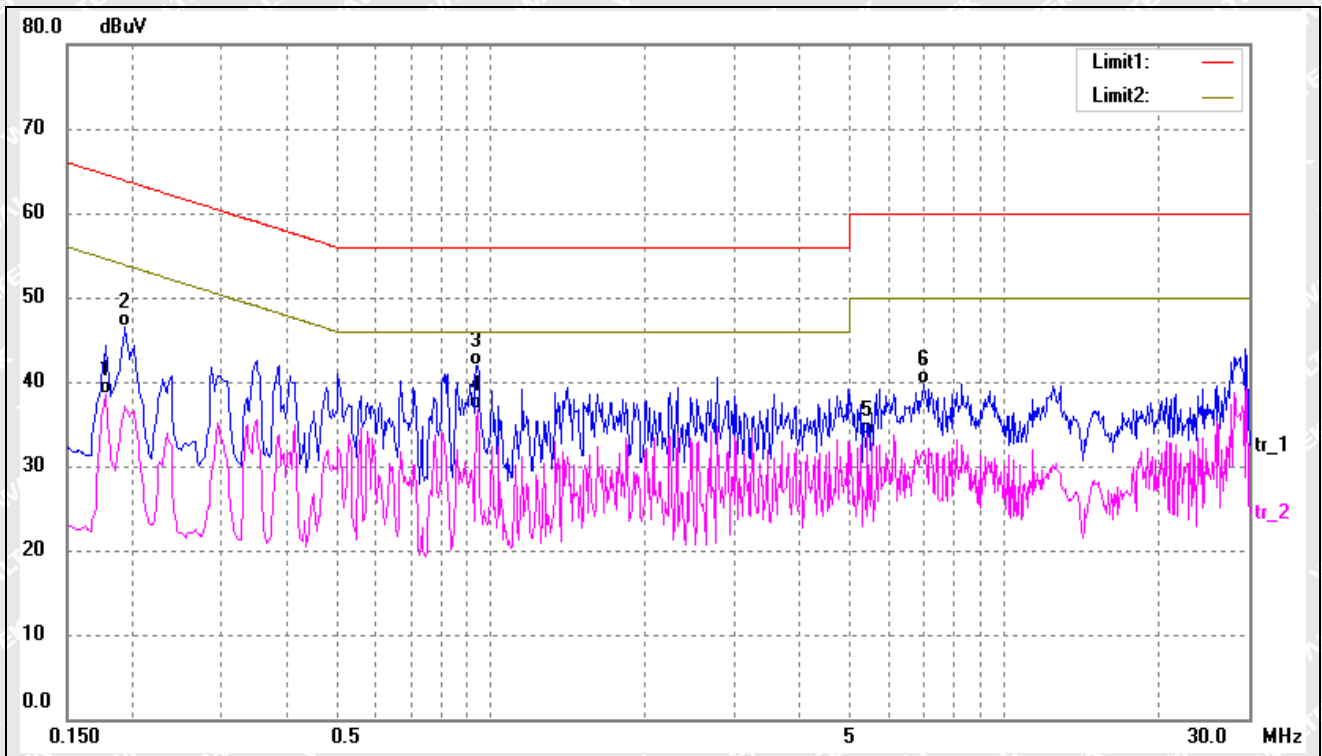
Temperature:	26 °C
Relative Humidity:	60 %
ATM Pressure:	1015 mbar

3.4 Conducted Emissions Test Data

Note: Only show the worst case in the test report.



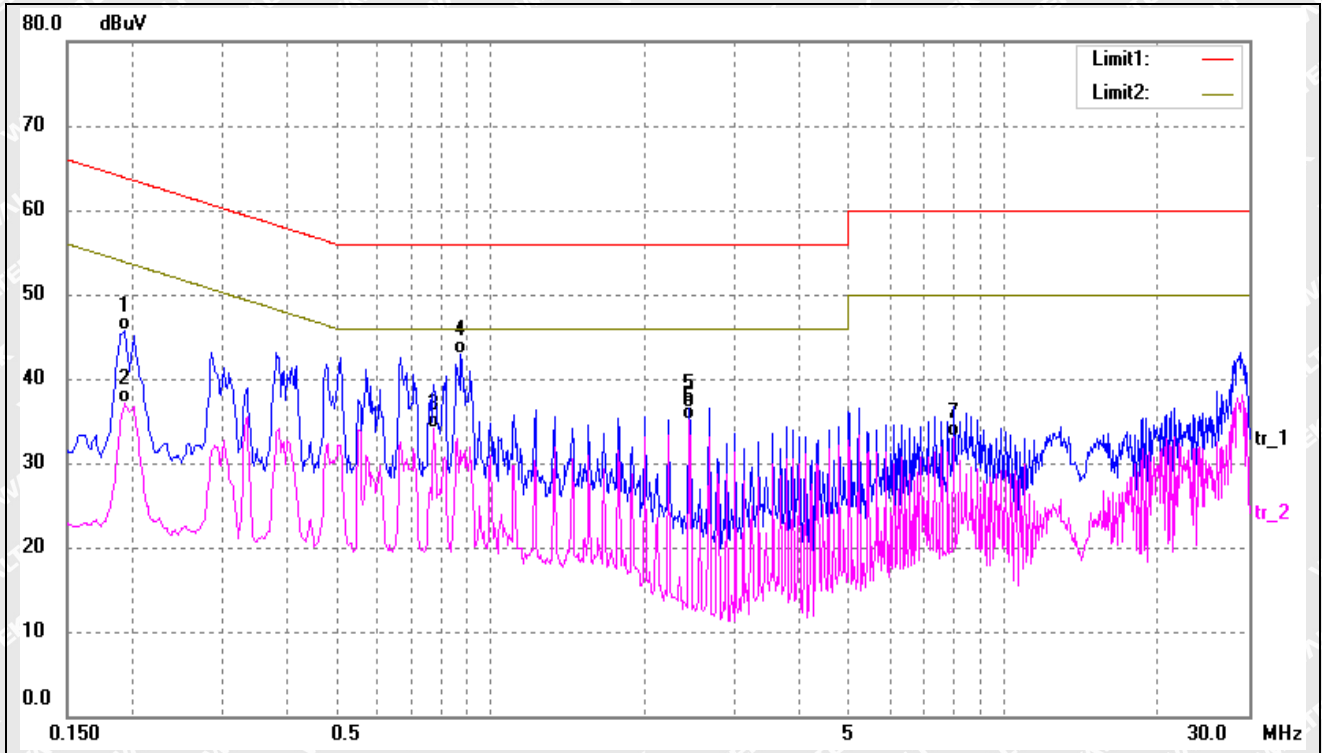
Test mode:	TM1	Polarity:	Neutral
------------	-----	-----------	---------



No.	Frequency (MHz)	Reading (dBuV)	Correct (dB)	Result (dBuV)	Limit (dBuV)	Margin (dB)	Detector
1	0.1779	28.21	10.37	38.58	54.58	-16.00	AVG
2	0.1940	36.14	10.37	46.51	63.86	-17.35	QP
3	0.9419	31.46	10.52	41.98	56.00	-14.02	QP
4*	0.9459	26.09	10.53	36.62	46.00	-9.38	AVG
5	5.4260	23.76	9.99	33.75	50.00	-16.25	AVG
6	6.9859	29.78	9.95	39.73	60.00	-20.27	QP



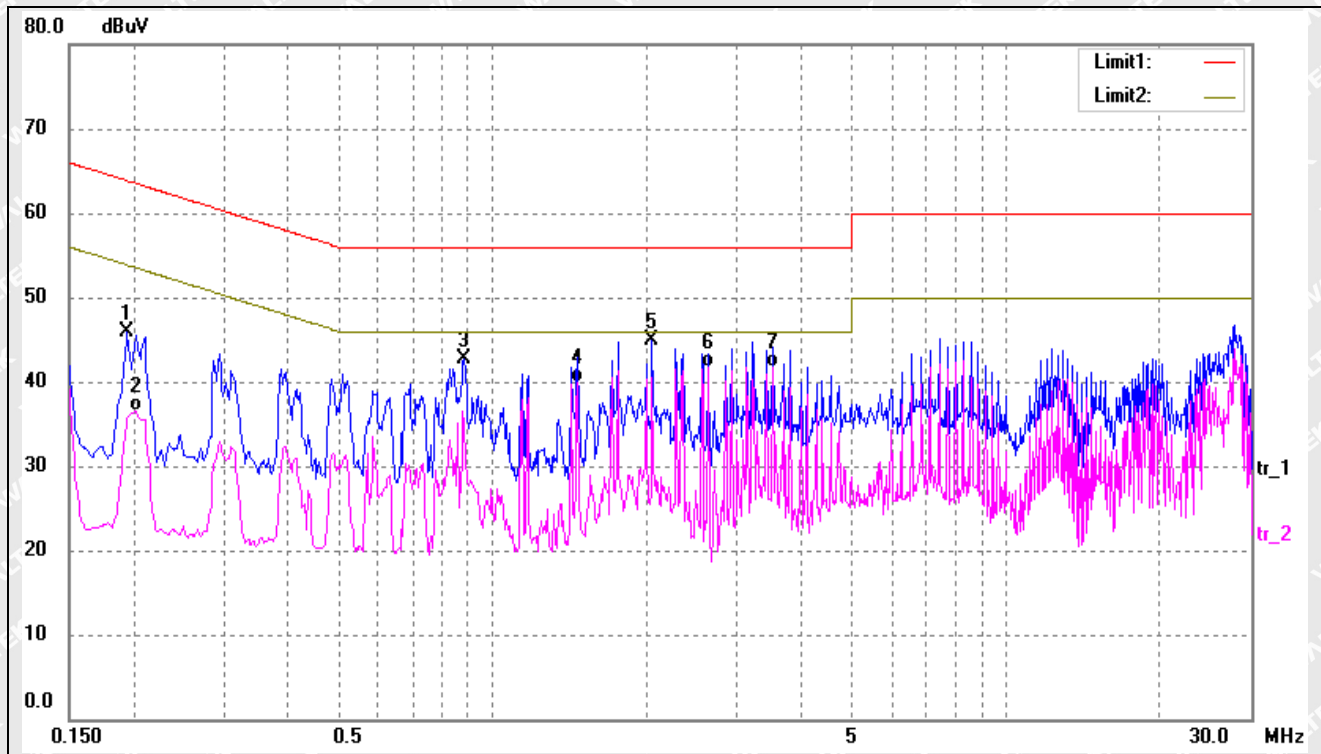
Test mode:	TM1	Polarity:	Line
------------	-----	-----------	------



No.	Frequency (MHz)	Reading (dBuV)	Correct (dB)	Result (dBuV)	Limit (dBuV)	Margin (dB)	Detector
1	0.1940	35.26	10.37	45.63	63.86	-18.23	QP
2	0.1940	26.80	10.37	37.17	53.86	-16.69	AVG
3	0.7780	23.76	10.43	34.19	46.00	-11.81	AVG
4	0.8780	32.37	10.49	42.86	56.00	-13.14	QP
5	2.4460	26.47	10.11	36.58	56.00	-19.42	QP
6*	2.4460	24.96	10.11	35.07	46.00	-10.93	AVG
7	8.0060	23.13	9.92	33.05	50.00	-16.95	AVG



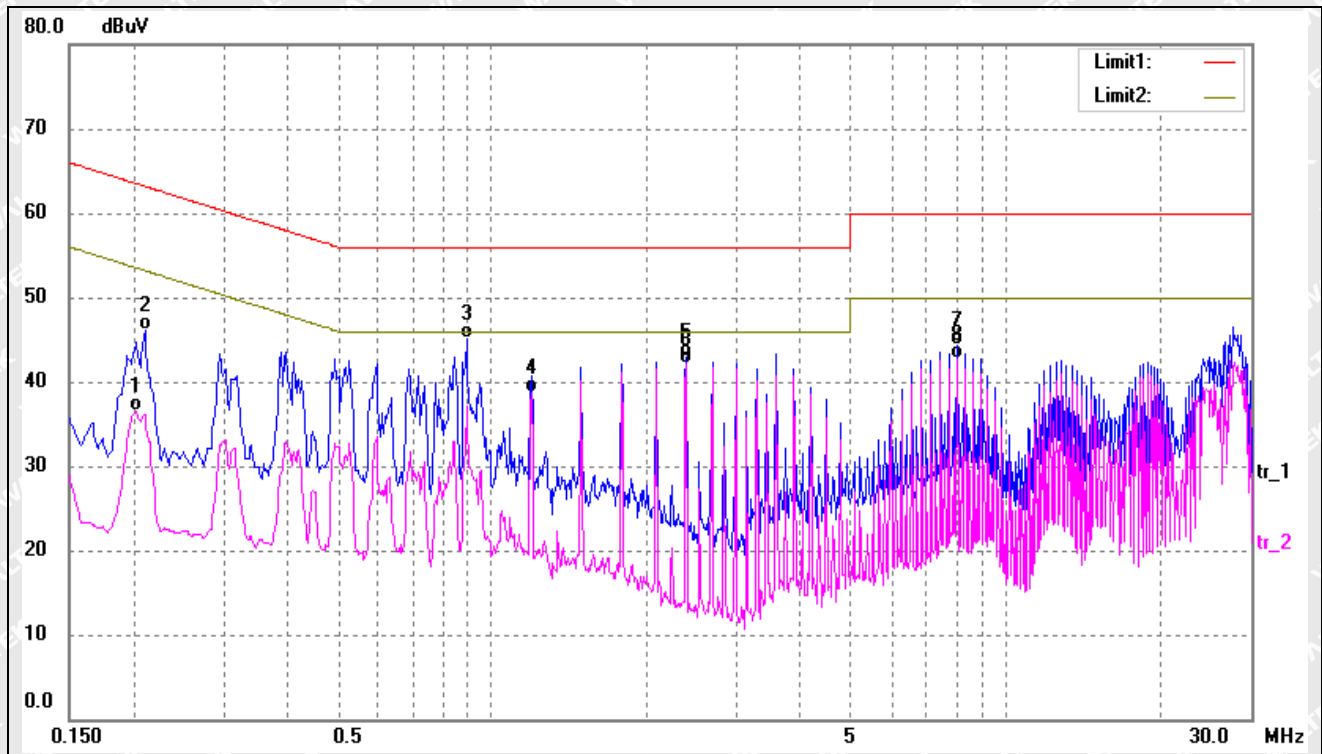
Test mode:	TM2	Polarity:	Neutral
------------	-----	-----------	---------



No.	Frequency (MHz)	Reading (dBuV)	Correct (dB)	Result (dBuV)	Limit (dBuV)	Margin (dB)	Detector
1	0.1940	35.58	10.37	45.95	63.86	-17.91	peak
2	0.2020	26.18	10.37	36.55	53.52	-16.97	AVG
3	0.8820	32.14	10.49	42.63	56.00	-13.37	peak
4	1.4660	29.52	10.36	39.88	46.00	-6.12	AVG
5	2.0500	34.84	10.13	44.97	56.00	-11.03	peak
6	2.6380	31.54	10.10	41.64	46.00	-4.36	AVG
7*	3.5180	31.73	10.06	41.79	46.00	-4.21	AVG



Test mode:	TM2	Polarity:	Line
------------	-----	-----------	------



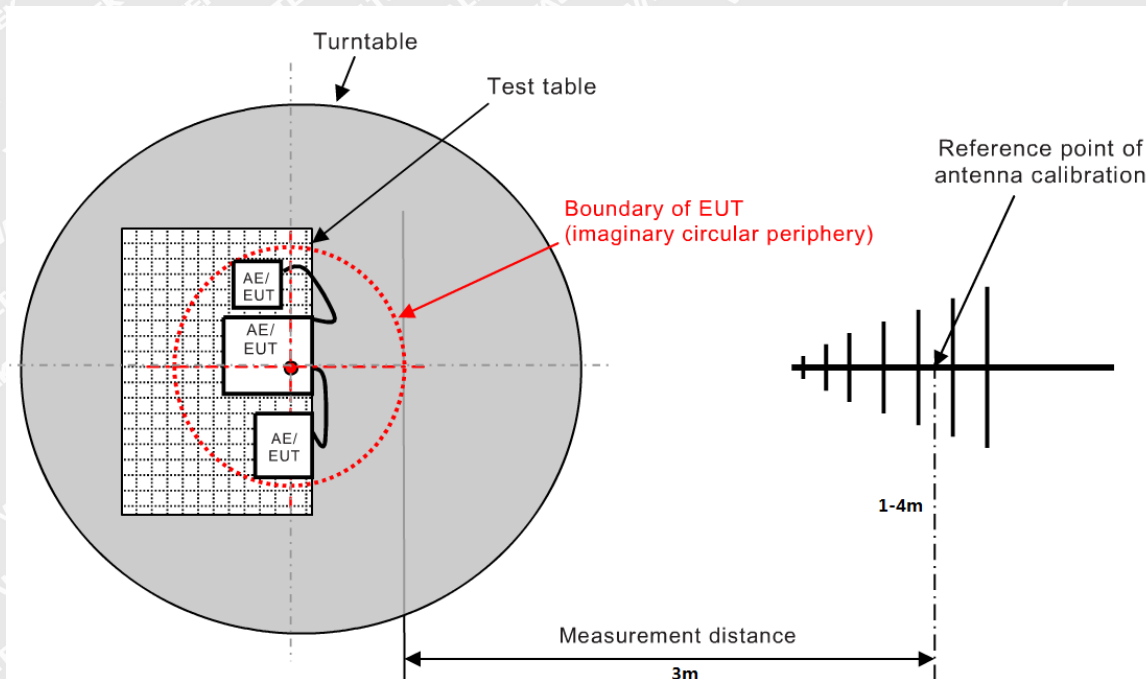
No.	Frequency (MHz)	Reading (dBuV)	Correct (dB)	Result (dBuV)	Limit (dBuV)	Margin (dB)	Detector
1	0.2020	26.11	10.37	36.48	53.53	-17.05	AVG
2	0.2100	35.65	10.37	46.02	63.21	-17.19	QP
3	0.8940	34.56	10.50	45.06	56.00	-10.94	QP
4	1.1940	28.20	10.47	38.67	46.00	-7.33	AVG
5	2.3860	32.72	10.11	42.83	56.00	-13.17	QP
6*	2.3860	31.97	10.11	42.08	46.00	-3.92	AVG
7	8.0500	34.32	9.92	44.24	60.00	-15.76	QP
8	8.0500	32.76	9.92	42.68	50.00	-7.32	AVG



4. Radiated Emissions

4.2 Test Procedure

Test is conducting under the description of EN55032 Information technology equipment - Radio disturbance characteristics - Limits and methods of measurement.



4.2 Corrected Amplitude & Margin Calculation

The Corrected Amplitude is calculated by adding the Antenna Factor and the Cable Factor, and subtracting the Amplifier Gain from the Amplitude reading. The basic equation is as follows:

$$\text{Corr. Ampl.} = \text{Indicated Reading} + \text{Antenna Factor} + \text{Cable Factor} - \text{Amplifier Gain}$$

The “**Margin**” column of the following data tables indicates the degree of compliance with the applicable limit. For example, a margin of $-6\text{dB}\mu\text{V}$ means the emission is $6\text{dB}\mu\text{V}$ below the maximum limit for Class B device. The equation for margin calculation is as follows:

$$\text{Margin} = \text{Corr. Ampl.} - \text{EN 301489 Class B Limit}$$



4.3 Environmental Conditions

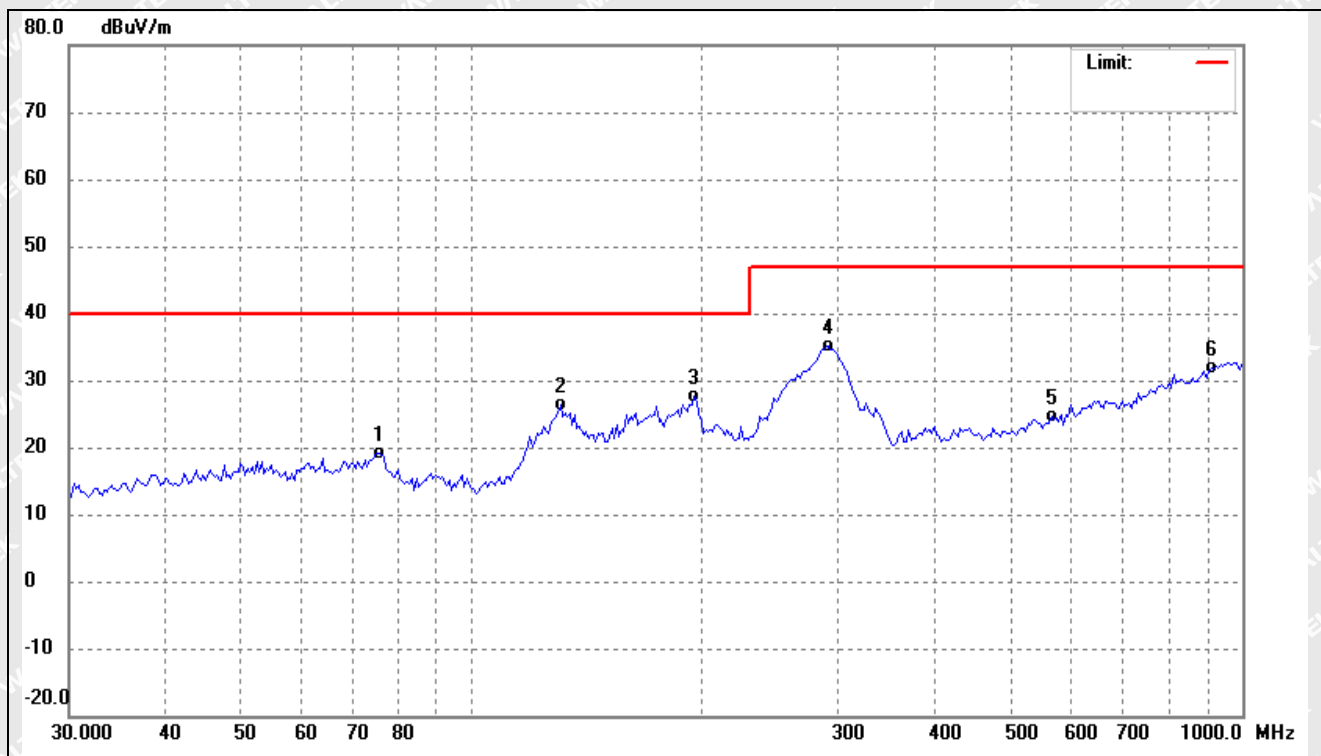
Temperature:	23.5° C
Relative Humidity:	54%
ATM Pressure:	1015 mbar

4.4 Summary of Test Results/Plots

Note: Only show the worst case in the test report

➤ 30MHz to 1GHz

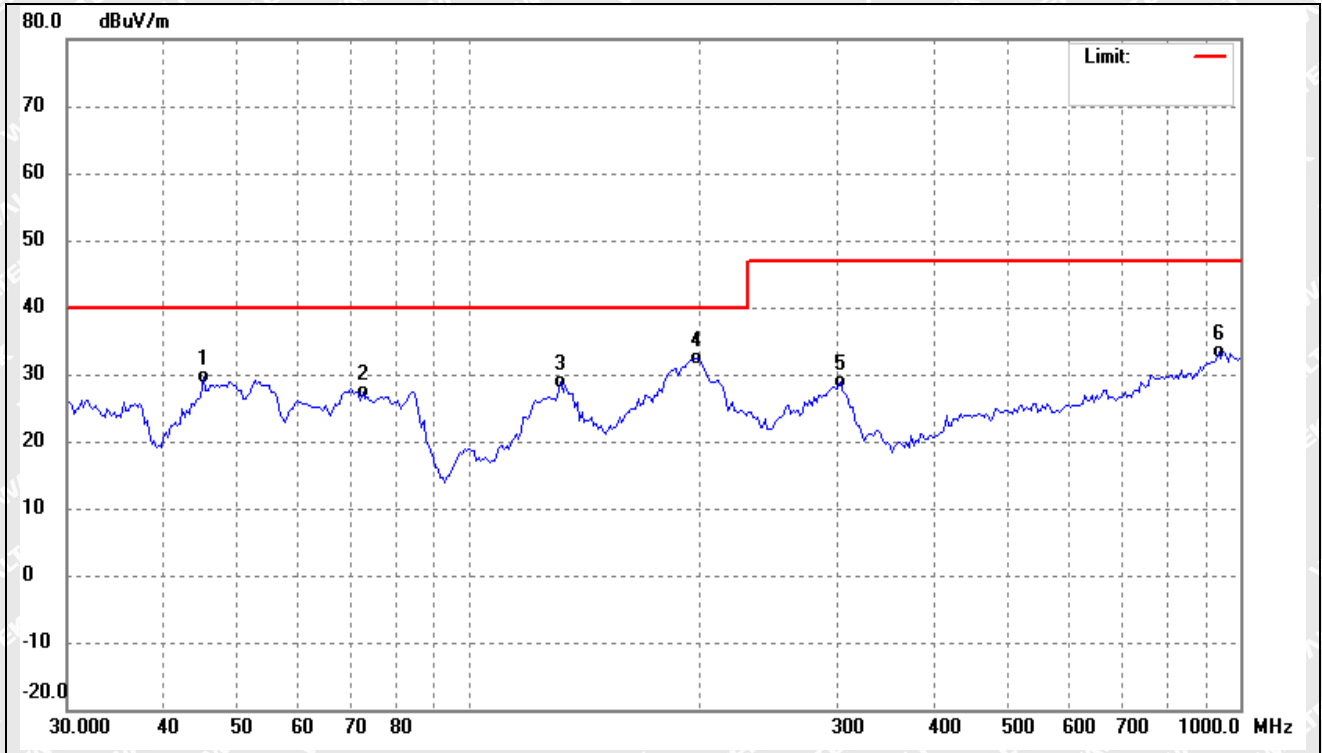
Test mode:	TM1	Polarity:	Horizontal
------------	-----	-----------	------------



No.	Frequency (MHz)	Reading (dBuV)	Correct (dB/m)	Result (dBuV/m)	Limit (dBuV/m)	Margin (dB)	Degree (deg.)	Height (cm)	Remark
1	75.8520	36.50	-17.29	19.21	40.00	-20.79	100	247	QP
2	130.3048	41.37	-15.06	26.31	40.00	-13.69	100	247	QP
3	194.4985	44.11	-16.58	27.53	40.00	-12.47	100	247	QP
4	290.3170	48.59	-13.44	35.15	47.00	-11.85	100	247	QP
5	565.9776	33.07	-8.51	24.56	47.00	-22.44	100	247	QP
6	912.6953	34.90	-3.12	31.78	47.00	-15.22	100	247	QP



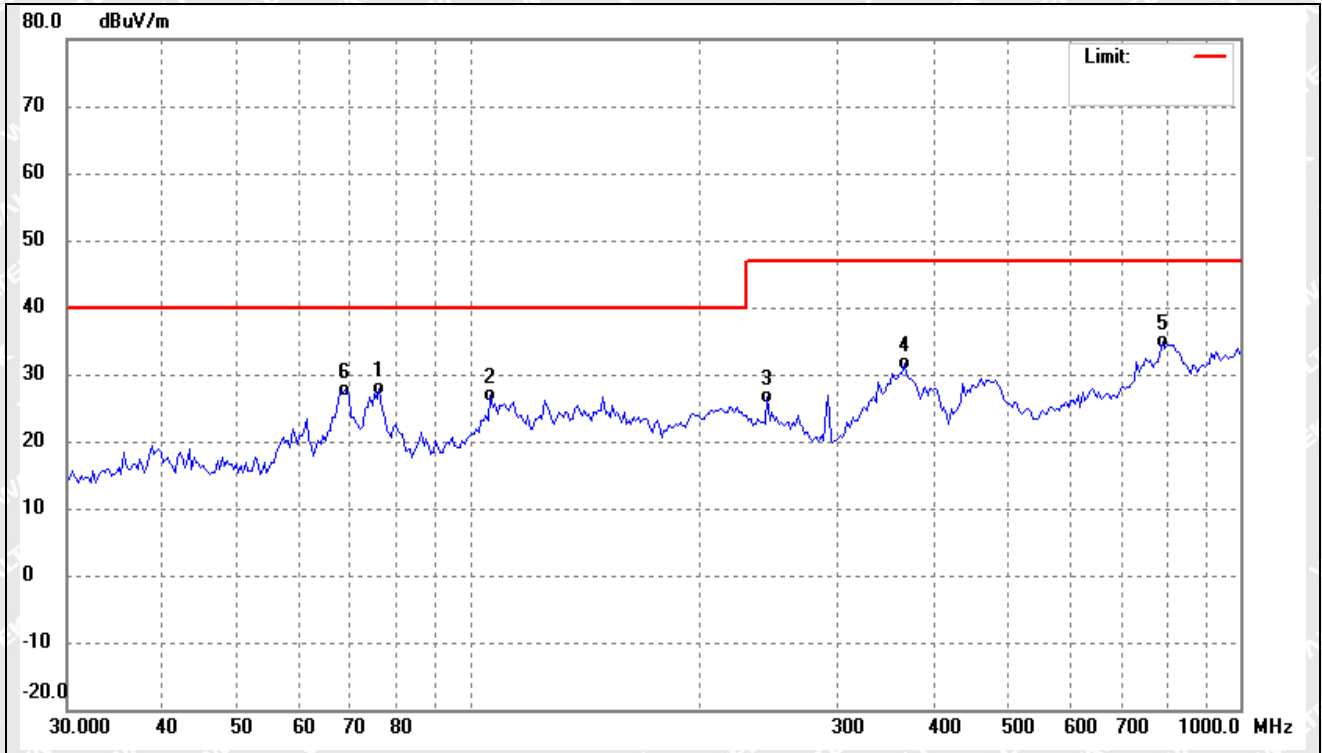
Test mode:	TM1	Polarity:	Vertical
------------	-----	-----------	----------



No.	Frequency (MHz)	Reading (dBuV)	Correct (dB/m)	Result (dBuV/m)	Limit (dBuV/m)	Margin (dB)	Degree (deg.)	Height (cm)	Remark
1	45.0951	43.19	-13.68	29.51	40.00	-10.49	100	47	QP
2	72.7203	44.07	-16.63	27.44	40.00	-12.56	100	47	QP
3	131.2236	43.80	-15.01	28.79	40.00	-11.21	100	47	QP
4	197.2514	49.10	-16.71	32.39	40.00	-7.61	100	47	QP
5	302.8193	41.77	-13.01	28.76	47.00	-18.24	100	47	QP
6	938.7139	36.11	-2.62	33.49	47.00	-13.51	100	47	QP



Test mode:	TM2	Polarity:	Horizontal
------------	-----	-----------	------------



No.	Frequency (MHz)	Reading (dBuV)	Correct (dB/m)	Result (dBuV/m)	Limit (dBuV/m)	Margin (dB)	Degree (deg.)	Height (cm)	Remark
1	76.3868	45.41	-17.41	28.00	40.00	-12.00			QP
2	106.2811	43.98	-17.05	26.93	40.00	-13.07			QP
3	243.5431	42.13	-15.47	26.66	47.00	-20.34			QP
4	366.0866	43.60	-12.08	31.52	47.00	-15.48			QP
5	793.0281	39.10	-4.21	34.89	47.00	-12.11			QP
6	68.7449	43.51	-15.85	27.66	40.00	-12.34			QP



Test mode:	TM2	Polarity:	Vertical
------------	-----	-----------	----------



No.	Frequency (MHz)	Reading (dBuV)	Correct (dB/m)	Result (dBuV/m)	Limit (dBuV/m)	Margin (dB)	Degree (deg.)	Height (cm)	Remark
1	30.2116	50.36	-14.56	35.80	40.00	-4.20	100	165	QP
2	75.8520	52.90	-17.29	35.61	40.00	-4.39	100	165	QP
3	97.0023	54.25	-17.80	36.45	40.00	-3.55	100	165	QP
4	107.7854	53.54	-16.92	36.62	40.00	-3.38	100	165	QP
5	124.0501	52.43	-15.45	36.98	40.00	-3.02	100	165	QP
6	142.7692	50.02	-14.47	35.55	40.00	-4.45	100	165	QP

Remark: '-' Means' the test Degree and Height are not recorded by the test software and only show the worst case in the test report.

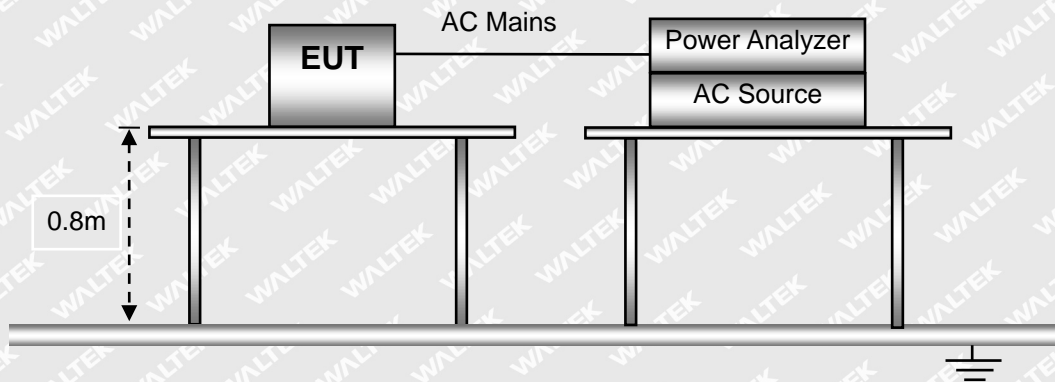


5. Harmonic Current Emissions

5.1 Test Procedure

Test is conducting under the description of EN 61000-3-2.

5.2 Test Setup Block Diagram



5.3 Test Standards

EN61000-3-2, Clause 7.1 Limits for Class A equipment.

5.4 Environmental Conditions

Temperature:	26 °C
Relative Humidity:	55%
ATM Pressure:	1015 mbar

5.5 Harmonic Current Emissions Test Data

According to Clause 7 of EN61000-3-2, the EUT rated power is less than 75W, belong to 'equipment with a rated power of 75W or less', therefore 'limits are not specified in this edition of the standards'. It is deem to full fit the requirements of the standards.

Result: The EUT complies with the requirements of this section.

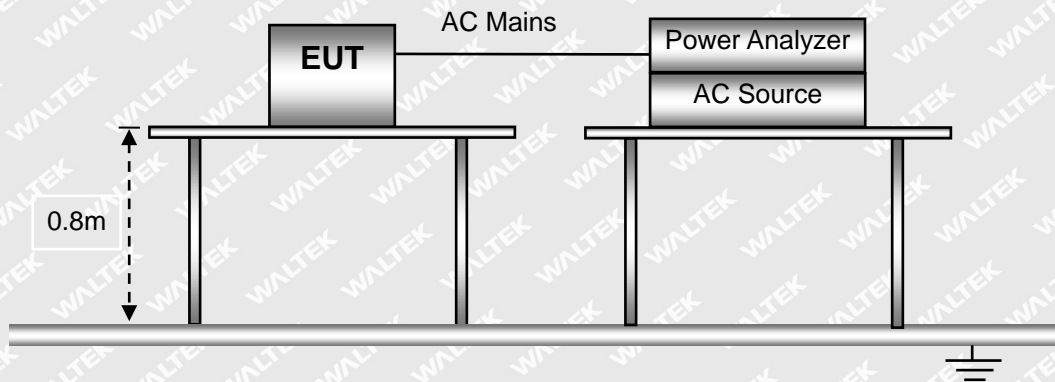


6. Voltage Fluctuation and Flicker

6.1 Test Procedure

Test is conducting under the description of EN 61000-3-3.

6.2 Test Setup Block Diagram



6.3 Test Standards

EN61000-3-3, Limit: Clause 5.

6.4 Environmental Conditions

Temperature:	26 °C
Relative Humidity:	55%
ATM Pressure:	1015 mbar

6.5 Voltage Fluctuation and Flicker Test Data

Result: The EUT is compliance with the requirements of this section.



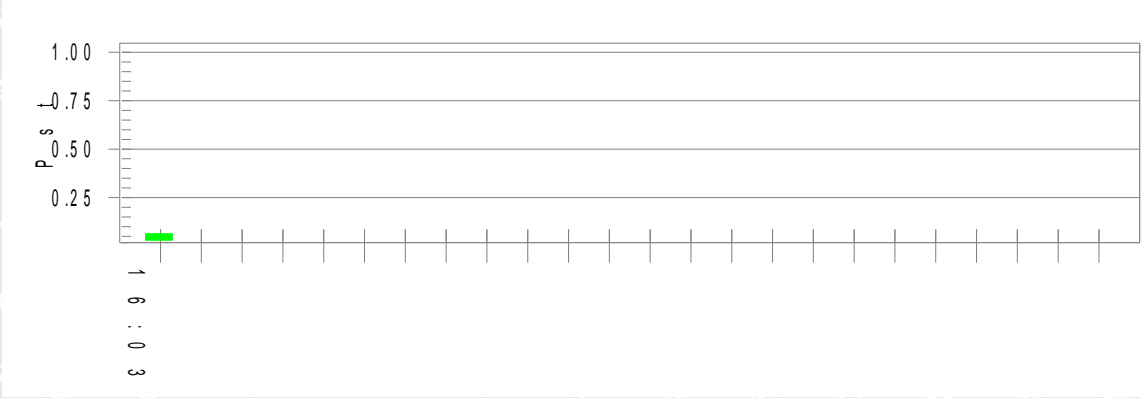
Test mode:	TM1
------------	-----

Test Result: Pass

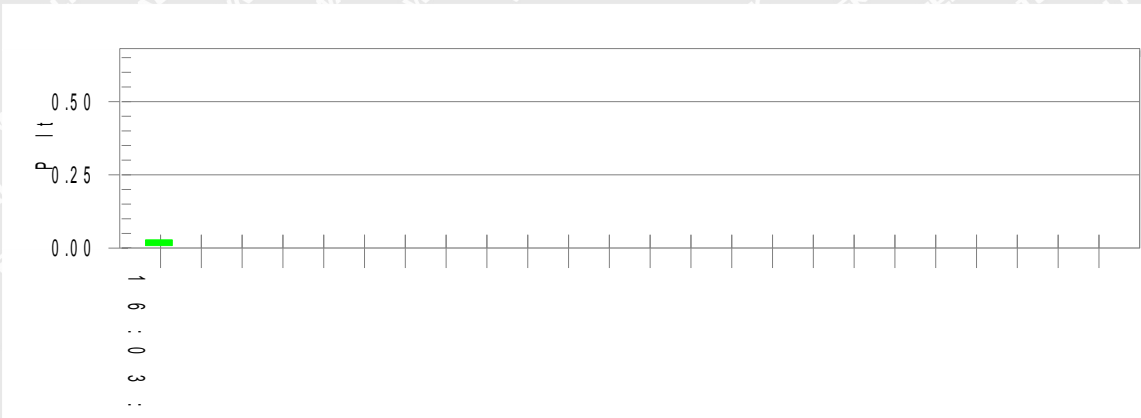
Status: Test Completed

Pst_i and limit line

European Limits



Plt and limit line



Parameter values recorded during the test:

Vrms at the end of test (Volt):	230.04			
T-max (mS):	0	Test limit (mS):	500.0	Pass
Highest dc (%):	0.00	Test limit (%):	3.30	Pass
Highest dmax (%):	0.00	Test limit (%):	4.00	Pass
Highest Pst (10 min. period):	0.064	Test limit:	1.000	Pass
Highest Plt (2 hr. period):	0.028	Test limit:	0.650	Pass



Test mode	TM1-TM3							
EN 61000-4-2 Test Points	Test Levels (kV)							
	-2	+2	-4	+4	-6	+6	-8	+8
Air Discharge								
TYPE-C Port	A	A	A	A	A	A	B	B
Enclosure	A	A	A	A	A	A	B	B
Direct Contact Discharge								
USB Port	A	A	B	B	/	/	/	/
Indirect Contact Discharge								
HCP (6 Sides)	A	A	A	A	/	/	/	/
VCP (4 Sides)	A	A	A	A	/	/	/	/

Test Result: Pass

WALTEK

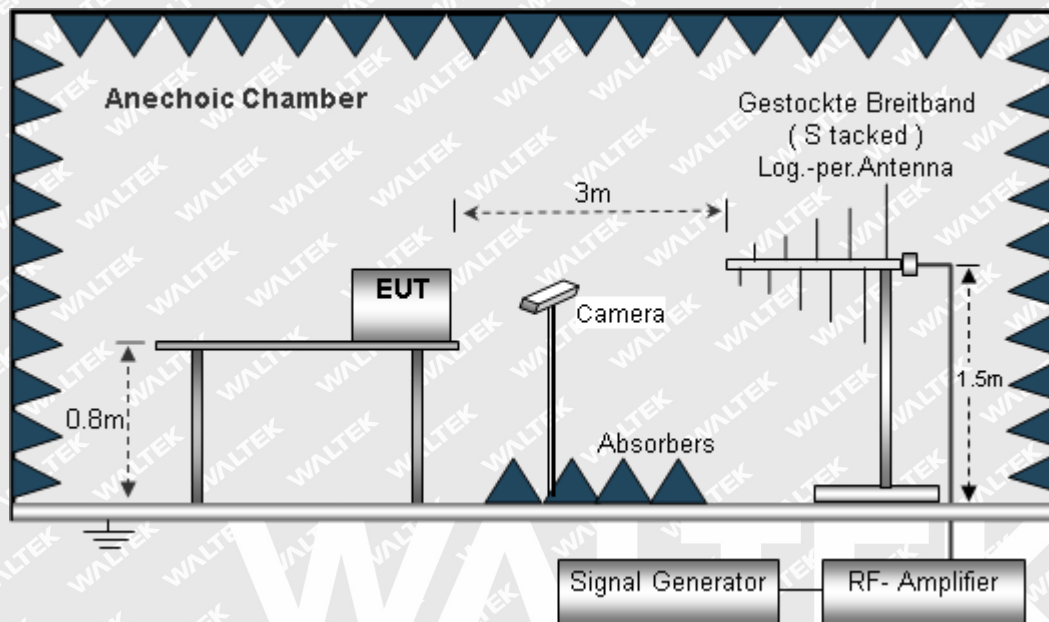


8. Radio Frequency Electromagnetic Field (R/S)

8.1 Test Procedure

Test is conducting under the description of EN 61000-4-3.

8.2 Test Setup Block Diagram



8.3 Test Performance

Performance Criterion:	Mode	Verdict
		TM1-TM3

Note: TM3 for CT,CR

8.4 Environmental Conditions

Temperature:	25 °C
Relative Humidity:	52%
ATM Pressure:	1010 mbar

8.5 Continuous Radiated Disturbances Test Data

Frequency step: 1% of fundamental

Dwell time: 1 second

Modulation: AM by 1kHz sine wave with 80% modulation depth



Test mode		TM1-TM3							
Frequency Range(MHz)	Field (V/m)	Front		Rear		Left Side		Right Side	
		VERT	HORI	VERT	HORI	VERT	HORI	VERT	HORI
80-1000	3	A	A	A	A	A	A	A	A
1000-3000	3	A	A	A	A	A	A	A	A
3000-6000	3	A	A	A	A	A	A	A	A

Test Result: Pass

WALTEK



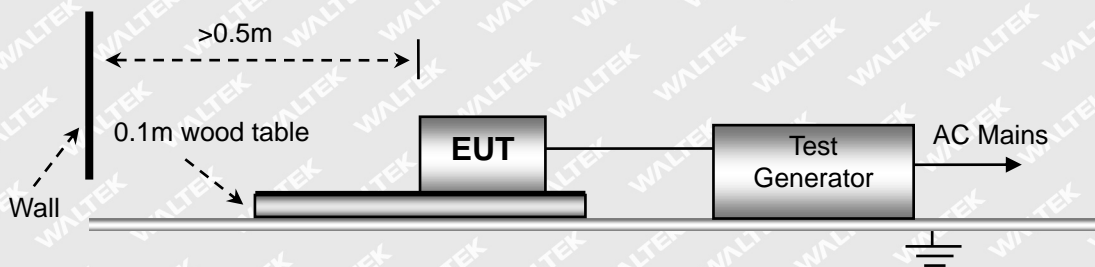
9. Fast Transients, Common Mode (EFT)

9.1 Test Procedure

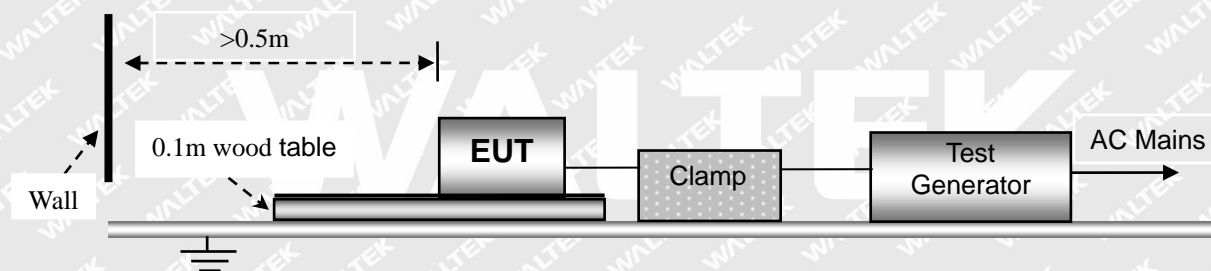
Test is conducting under the description of EN 61000-4-4.

9.2 Test Setup Block Diagram

For AC Mains or DC Ports:



For Signal or Telecommunication Ports:



9.3 Test Performance

Performance Criterion:	Mode	Verdict
		TM1-TM3

Note: TM3 for TT,TR

9.4 Environmental Conditions

Temperature:	22 °C
Relative Humidity:	53%
ATM Pressure:	1011 mbar

9.5 Electrical Fast Transients Test Data



Test Mode		TM1-TM3							
EN 61000-4-4 Test Line		Test Levels (kV)							
		+0.5	-0.5	+1.0	-1.0	+2.0	-2.0	+4.0	-4.0
AC Main Power port	L	A	A	A	A	/	/	/	/
	N	A	A	A	A	/	/	/	/
	PE	/	/	/	/	/	/	/	/
	L-N	A	A	A	A	/	/	/	/
	L-PE	/	/	/	/	/	/	/	/
	N-PE	/	/	/	/	/	/	/	/
	L-N-PE	/	/	/	/	/	/	/	/
Signal ports	/	/	/	/	/	/	/	/	

Test Result: Pass

WALTEK



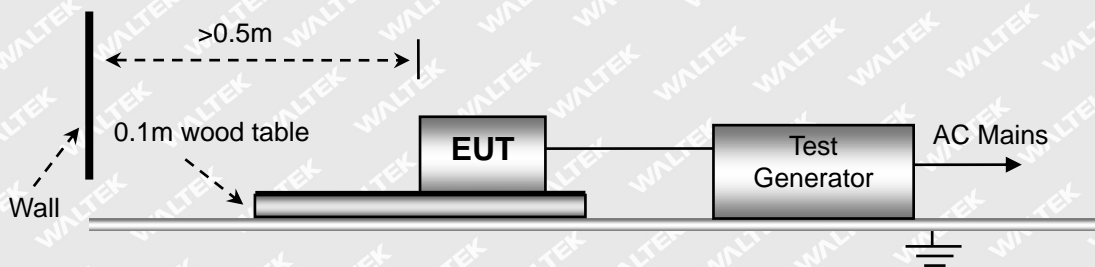
10. Surges

10.1 Test Procedure

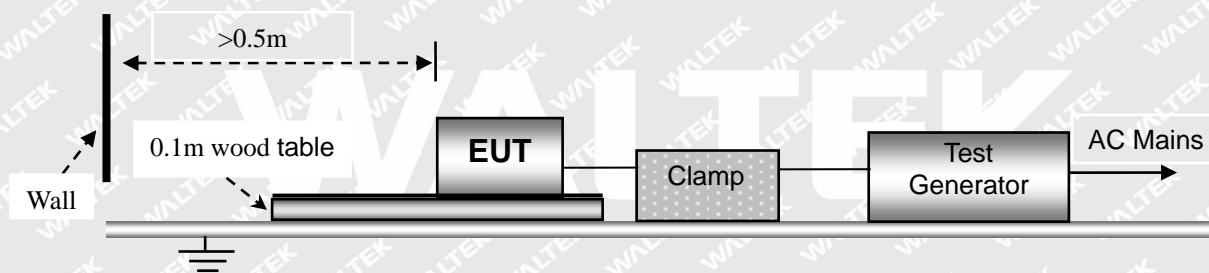
Test is conducting under the description of EN 61000-4-5.

10.2 Test Setup Block Diagram

For AC Mains or DC Ports:



For Signal or Telecommunication Ports:



10.3 Test Performance

Performance Criterion:	Mode	Verdict
		TM1-TM3

Note: TM3 for TT,TR

10.4 Environmental Conditions

Temperature:	25 °C
Relative Humidity:	53%
ATM Pressure:	1011 mbar

10.5 Surge Test Data



Test Mode	TM1-TM3			
Voltage	Poll	Path	Pass	Fail
0.5kV	±	L-N	A	/
1kV	±	L-N	A	/
2kV	±	L-N, L-PE, N-PE	/	/
4kV	±	L-N, L-PE, N-PE	/	/

Test Result: Pass

WALTEK



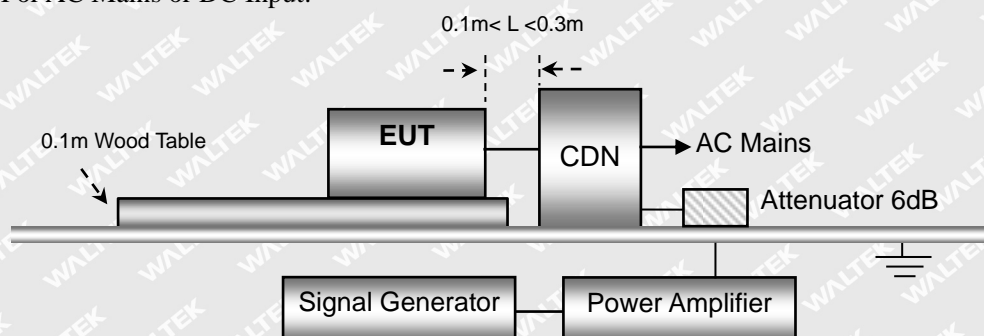
11. Radio Frequency, Common Mode (C/S)

11.1 Test Procedure

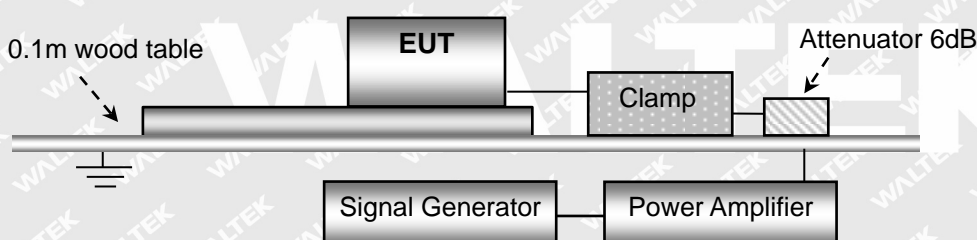
Test is conducting under the description of EN 61000-4-6.

11.2 Test Setup Block Diagram

For AC Mains or DC Input:



For Signal or Telecommunication Ports:



11.3 Test Performance

Performance Criterion:	Mode	Verdict
	TM1-TM3	A
Note: TM3 for CT,CR		

11.4 Environmental Conditions

Temperature:	25 °C
Relative Humidity:	53%
ATM Pressure:	1011 mbar

11.5 Continuous Conducted Disturbances Test Data

Sweep frequency range: 150kHz~80MHz

Frequency step: 1% of fundamental

Dwell time: 1 second

Waltek Testing Group (Shenzhen) Co., Ltd.

[Http://www.waltek.com.cn](http://www.waltek.com.cn)



Test Mode		TM1-TM3		
Level	Voltage (V) (rms, unmodulated)	Modulation:	Pass	Fail
1	1	AM 80%, 1kHz sinewave	/	/
2	3	AM 80%, 1kHz sinewave	A	/
3	10	AM 80%, 1kHz sinewave	/	/
X	Special	/	/	/

Test Result: Pass

WALTEK

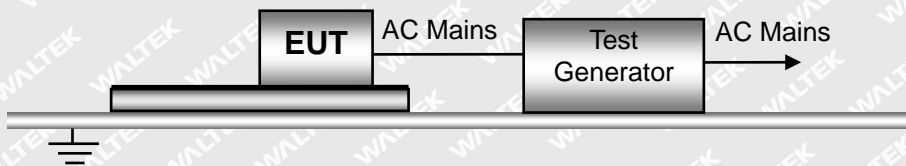


12. Voltage Dips and Interruptions

12.1 Test Procedure

Test is conducting under the description of EN 61000-4-11.

12.2 Test Setup Block Diagram



12.3 Test Performance

Performance Criterion:	Mode	Verdict
	TM1-TM3	B for voltage dip/ C for voltage interruption
Note: TM3 for TT,TR		

12.4 Environmental Conditions

Temperature:	25 °C
Relative Humidity:	50%
ATM Pressure:	1011 mbar

12.5 Voltage Dips And Interruptions Test Data

U: Voltage dips in % U_T (U_T is rated voltage for the EUT)

T: Test duration

Level	U	T	Phase Angle	N	Pass	Fail
1	100%	10ms	0/90/180/270	3	A	/
2	100%	20ms	0/90/180/270	3	B	/
3	30%	500ms	0/90/180/270	3	B	/
4	100%	5000ms	0/90/180/270	3	C	/

Test Result: Pass



EXHIBIT 1 - EUT PHOTOGRAPHS

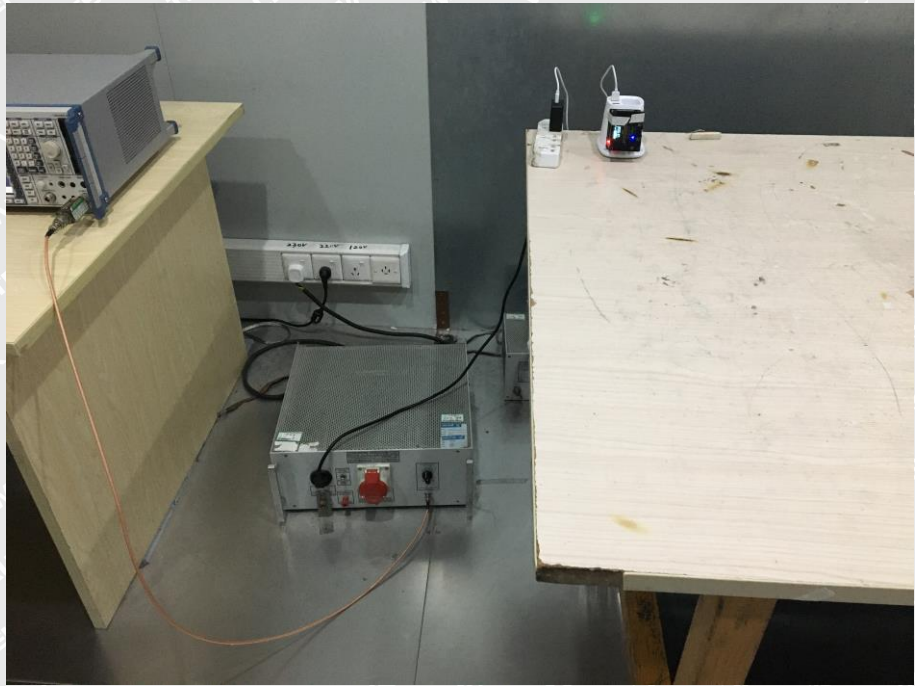
Please refer to “ANNEX”.

WALTEK

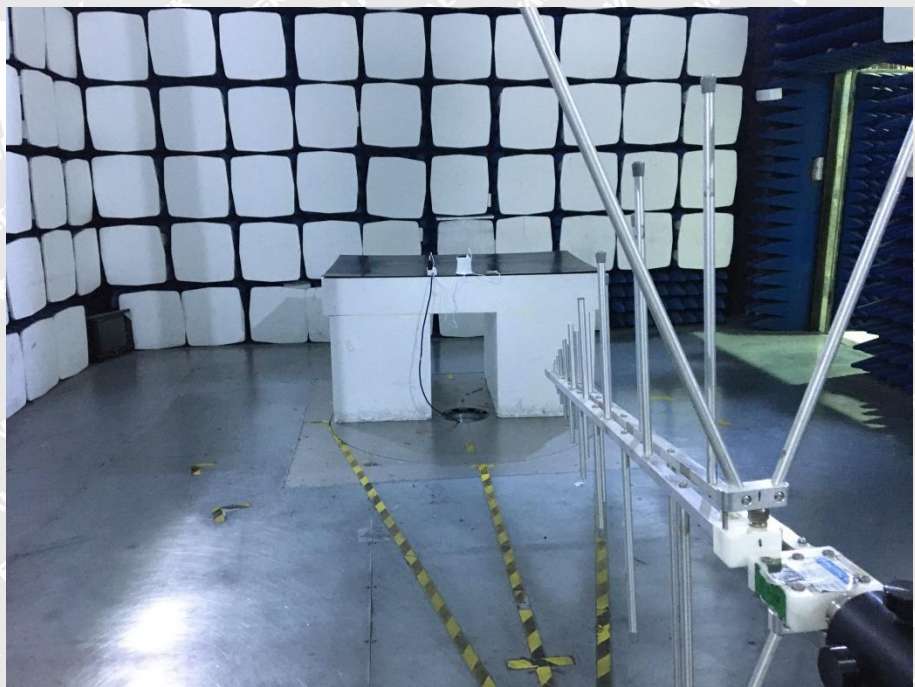


EXHIBIT 2 - TEST SETUP PHOTOGRAPHS

**Conducted Emission
Test Setup**



**Radiation Emission Test
View(30MHz to 1GHz)**

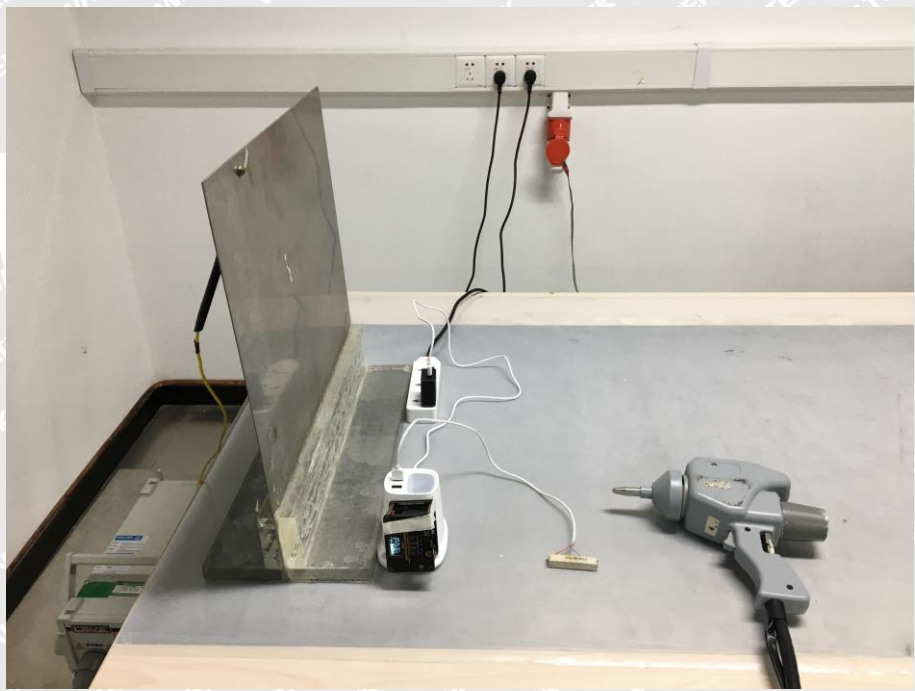




Flicker Test View

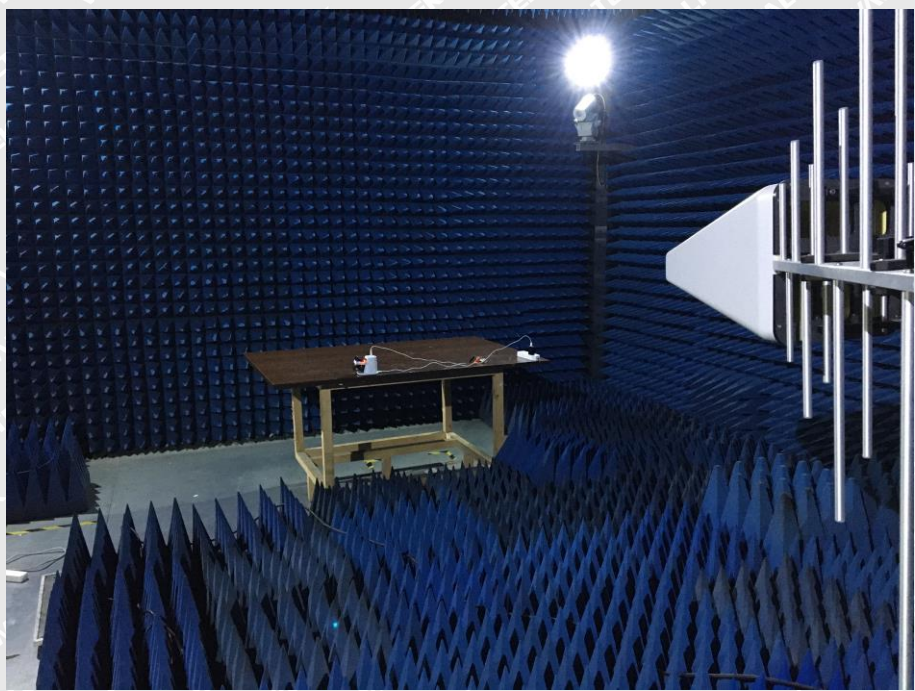


EN 61000-4-2 Test View

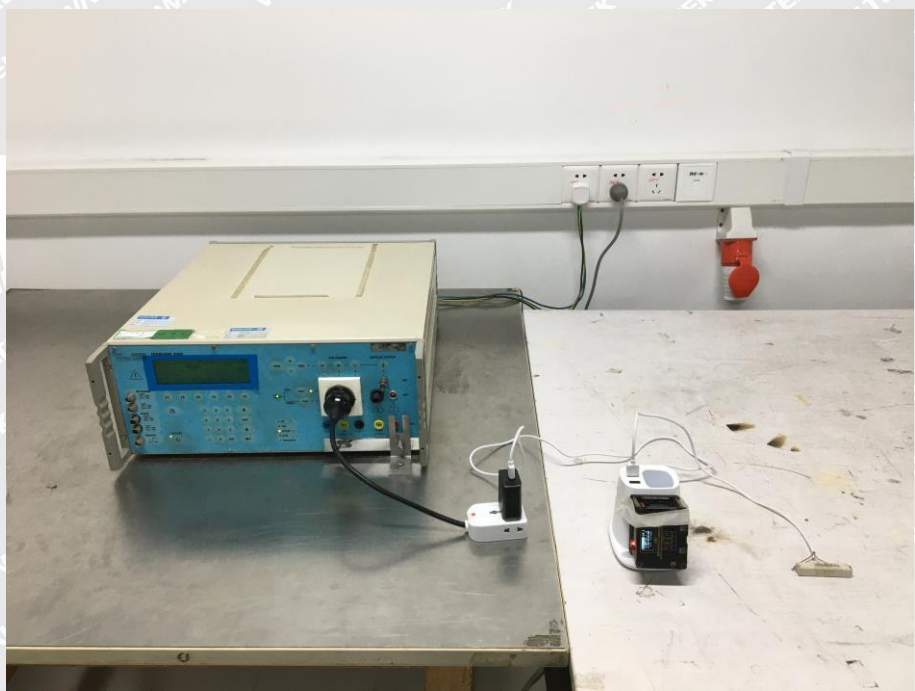




EN 61000-4-3 Test View

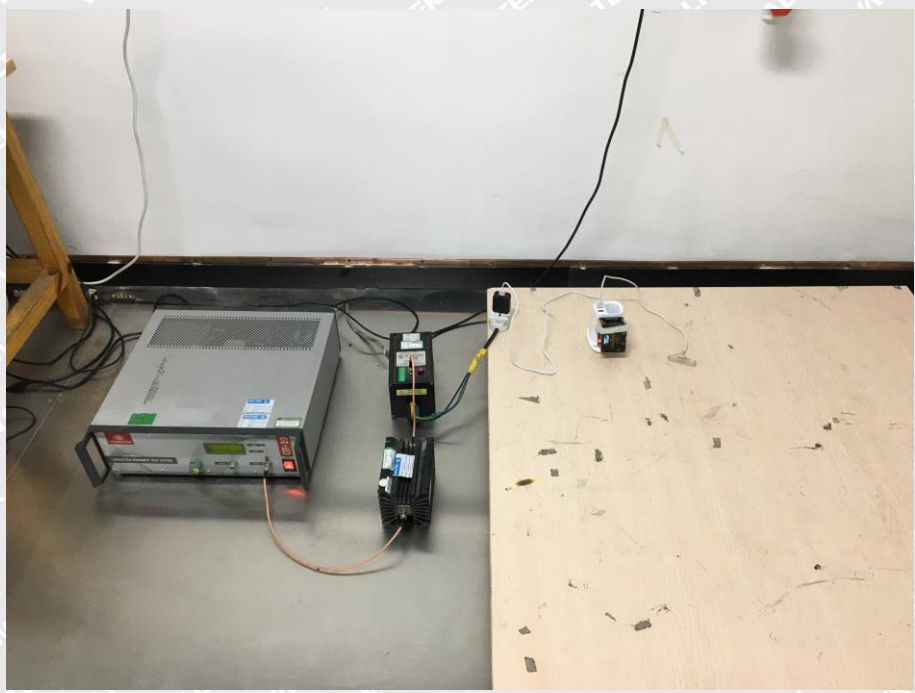


EN 61000-4-4/5/11 Test View





EN 61000-4-6 Test View



******* END OF REPORT *******

WALTEK