



TEST REPORT

Reference No...... : WTF21X10112642W-3
Manufacturer : Mid Ocean Brands B.V.
Address : 7/F., Kings Tower, 111 King Lam Street, Cheung Sha Wan, Kowloon, Hong Kong
Factory : 114538
Product : Desk light wireless charger
Test Model : MO6514
Standards : EN IEC 61000-6-1:2019
EN IEC 61000-3-2:2019
EN 61000-3-3:2014+A1:2019
ETSI EN 301 489-1 V2.2.3 (2019-11)
ETSI EN 301 489-3 V2.1.1 (2019-03)
Date of Receipt sample : Oct. 22, 2021
Date of Test..... : Oct. 22, 2021 to Nov. 25, 2021
Date of Issue : Nov. 25, 2021
Test Result..... : **Pass**

Remarks:

The results shown in this test report refer only to the sample(s) tested, this test report cannot be reproduced, except in full, without prior written permission of the company. The report would be invalid without specific stamp of test institute and the signatures of compiler and approver.

Prepared By:

Waltek Testing Group (Shenzhen) Co., Ltd.

Address: 1/F., Room 101, Building 1, Hongwei Industrial Park, Liuxian 2nd Road,
Block 70 Bao'an District, Shenzhen, Guangdong, China

Tel.: +86-755-33663308

Fax.: +86-755-33663309

Tested by:

Reviewed By:

Approved & Authorized By:

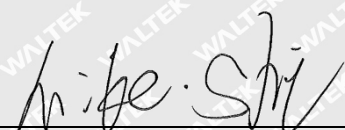
Jason Su / Project Engineer

Jason Su / RF Manager

Silin Chen / Manager



TABLE OF CONTENTS

1. GENERAL INFORMATION.....	5
1.1 PRODUCT DESCRIPTION FOR EQUIPMENT UNDER TEST (EUT).....	5
1.2 TEST STANDARDS.....	6
1.3 TEST METHODOLOGY.....	6
1.4 TEST FACILITY.....	6
1.5 EUT SETUP AND OPERATION MODE.....	6
1.6 PERFORMANCE CRITERIA FOR EMS.....	8
1.7 MEASUREMENT UNCERTAINTY.....	9
1.8 TEST EQUIPMENT LIST AND DETAILS.....	10
2. SUMMARY OF TEST RESULTS.....	12
3. CONDUCTED EMISSIONS.....	13
3.1 TEST PROCEDURE.....	13
3.2 BASIC TEST SETUP BLOCK DIAGRAM.....	13
3.3 ENVIRONMENTAL CONDITIONS.....	13
3.4 CONDUCTED EMISSIONS TEST DATA.....	13
4. RADIATED EMISSIONS.....	20
4.2 TEST PROCEDURE.....	20
4.2 CORRECTED AMPLITUDE & MARGIN CALCULATION.....	20
4.3 ENVIRONMENTAL CONDITIONS.....	21
4.4 SUMMARY OF TEST RESULTS/PLOTS.....	21
5. HARMONIC CURRENT EMISSIONS.....	27
5.1 TEST PROCEDURE.....	27
5.2 TEST SETUP BLOCK DIAGRAM.....	27
5.3 TEST STANDARDS.....	27
5.4 ENVIRONMENTAL CONDITIONS.....	27
5.5 HARMONIC CURRENT EMISSIONS TEST DATA.....	27
6. VOLTAGE FLUCTUATION AND FLICKER.....	28
6.1 TEST PROCEDURE.....	28
6.2 TEST SETUP BLOCK DIAGRAM.....	28
6.3 TEST STANDARDS.....	28
6.4 ENVIRONMENTAL CONDITIONS.....	28
6.5 VOLTAGE FLUCTUATION AND FLICKER TEST DATA.....	28
7. ELECTROSTATIC DISCHARGE (ESD).....	30
7.1 TEST PROCEDURE.....	30
7.2 TEST SETUP BLOCK DIAGRAM.....	30
7.3 TEST PERFORMANCE.....	30
7.4 ENVIRONMENTAL CONDITIONS.....	30
7.5 ELECTROSTATIC DISCHARGE IMMUNITY TEST DATA.....	30
8. RADIO FREQUENCY ELECTROMAGNETIC FIELD (R/S).....	32
8.1 TEST PROCEDURE.....	32
8.2 TEST SETUP BLOCK DIAGRAM.....	32
8.3 TEST PERFORMANCE.....	32
8.4 ENVIRONMENTAL CONDITIONS.....	32
8.5 CONTINUOUS RADIATED DISTURBANCES TEST DATA.....	32
9. FAST TRANSIENTS, COMMON MODE (EFT).....	34
9.1 TEST PROCEDURE.....	34
9.2 TEST SETUP BLOCK DIAGRAM.....	34
9.3 TEST PERFORMANCE.....	34
9.4 ENVIRONMENTAL CONDITIONS.....	34
9.5 ELECTRICAL FAST TRANSIENTS TEST DATA.....	34



10. SURGES	36
10.1 TEST PROCEDURE.....	36
10.2 TEST SETUP BLOCK DIAGRAM.....	36
10.3 TEST PERFORMANCE.....	36
10.4 ENVIRONMENTAL CONDITIONS.....	36
10.5 SURGE TEST DATA.....	36
11. RADIO FREQUENCY, COMMON MODE (C/S)	38
11.1 TEST PROCEDURE.....	38
11.2 TEST SETUP BLOCK DIAGRAM.....	38
11.3 TEST PERFORMANCE.....	38
11.4 ENVIRONMENTAL CONDITIONS.....	38
11.5 CONTINUOUS CONDUCTED DISTURBANCES TEST DATA.....	38
12. VOLTAGE DIPS AND INTERRUPTIONS	40
12.1 TEST PROCEDURE.....	40
12.2 TEST SETUP BLOCK DIAGRAM.....	40
12.3 TEST PERFORMANCE.....	40
12.4 ENVIRONMENTAL CONDITIONS.....	40
12.5 VOLTAGE DIPS AND INTERRUPTIONS TEST DATA.....	40
EXHIBIT 1 - EUT PHOTOGRAPHS	41
EXHIBIT 2 - TEST SETUP PHOTOGRAPHS	42

WALTEK



Report version

Version No.	Date of issue	Description
Rev.00	Nov. 25, 2021	Original
/	/	/

WALTEK



1. GENERAL INFORMATION

1.1 Product Description for Equipment Under Test (EUT)

Client Information

Manufacturer: Mid Ocean Brands B.V.
Address of manufacturer: 7/F., Kings Tower, 111 King Lam Street, Cheung Sha Wan,
Kowloon, Hong Kong

Factory: 114538

General Description of EUT	
Product Name:	Desk light wireless charger
Trade Name:	/
Model No.:	MO6514
Adding Model(s):	/
Rate Power:	Wireless output:5W/7.5W/10W/15W
Battery Capacity:	/
Power Adaptor Model:	/
Software Version:	7919BD
Hardware Version:	DF-1080
<i>Note: The test data is gathered from a production sample, provided by the manufacturer.</i>	

Technical Characteristics of EUT	
EN 303417	
Frequency Range:	110-205kHz
Radiated H-Field:	43.70dBuA/m(@3m)
Type of Antenna:	Coil Antenna



1.2 Test Standards

The tests were performed according to following standards:

EN IEC 61000-6-1:2019 Electromagnetic compatibility (EMC) —Part 6-1: Generic standards —Immunity for residential, commercial and light-industrial environments.

EN IEC 61000-3-2:2019 Electromagnetic compatibility (EMC) -- Part 3-2: Limits - Limits for harmonic current emissions (equipment input current up to and including 16 A per phase).

EN 61000-3-3:2013+A1:2019 Electromagnetic compatibility (EMC) -- Part 3-3: Limits - Limitation of voltage changes, voltage fluctuations and flicker in public low-voltage supply systems, for equipment with rated current ≤ 16 A per phase and not subject to conditional connection.

ETSI EN 301 489-1 V2.2.3 (2019-11): Electromagnetic Compatibility (EMC) standard for radio equipment and services; Part 1: Common technical requirements; Harmonised Standard for Electromagnetic Compatibility.

ETSI EN 301 489-3 V2.1.1 (2019-03): Electromagnetic Compatibility (EMC) standard for radio equipment and services; Part 3: Specific conditions for Short-Range Devices (SRD) operating on frequencies between 9 kHz and 246 GHz; Harmonised Standard covering the essential requirements of article 3.1(b) of Directive 2014/53/EU.

Maintenance of compliance is the responsibility of the manufacturer. Any modification of the product maybe which result in lowering the emission/immunity should be checked to ensure compliance has been maintained.

1.3 Test Methodology

All measurements contained in this report were conducted with the standard ETSI EN 301489-1, Electromagnetic compatibility and Radio spectrum Matters (ERM); Electromagnetic Compatibility (EMC) standard for radio equipment and services; Part 1: Common technical requirements.

1.4 Test Facility

FCC – Registration No.: 125990

Waltek Testing Group (Shenzhen) Co., Ltd. Laboratory has been recognized to perform compliance testing on equipment subject to the Commissions Declaration Of Conformity (DOC). The Designation Number is CN5010, and Test Firm Registration Number is 125990.

Industry Canada (IC) Registration No.: 11464A

The 3m Semi-anechoic chamber of Waltek Testing Group (Shenzhen) Co., Ltd. has been registered by Certification and Engineering Bureau of Industry Canada for radio equipment testing with Registration No.: 11464A.

1.5 EUT Setup and Operation Mode

Waltek Testing Group (Shenzhen) Co., Ltd.
[Http://www.waltek.com.cn](http://www.waltek.com.cn)



The equipment under test (EUT) was configured to measure its highest possible emission/immunity level. The test modes were adapted according to the operation manual for use, more detailed description as follows:

Test Mode List		
Test Mode	Description	Remark
TM1	Wireless Charging& Light on	Connect to the AC230V/50Hz Voltage; Output 5W, and Light on
TM2	Wireless Charging& Light on	Connect to the AC230V/50Hz Voltage; Output 10W, and Light on
TM3	Wireless Charging& Light on	Connect to the AC230V/50Hz Voltage; Output 15W, and Light on
TM3	Wireless Charging	TT,CT for EMS testing

EUT Cable List and Details			
Cable Description	Length (m)	Shielded/Unshielded	With / Without Ferrite
USB Cable	0.98	Unshielded	Without Ferrite

Special Cable List and Details			
Cable Description	Length (m)	Shielded/Unshielded	With / Without Ferrite
/	/	/	/

Auxiliary Equipment List and Details			
Description	Manufacturer	Model	Serial Number
Adapter	/	QC01	/



1.6 Performance Criteria for EMS

➤ EN 301 489-3, The performance criteria are:

In the table below:

- performance criterion A applies for immunity tests with phenomena of a continuous nature;
- performance criterion B applies for immunity tests with phenomena of a transient nature.

NOTE: Whether a phenomenon is considered transient, continuous or otherwise is indicated in the test procedures for the phenomenon in ETSI EN 301 489-1 [1], clause 9.

Table 2: Performance Requirements

Criterion	During test	After test
A	Operate as intended No loss of function No unintentional responses	Operate as intended No loss of function No degradation of performance No loss of stored data or user programmable functions
B	May show loss of function No unintentional responses	Operate as intended Lost function(s) shall be self-recoverable No degradation of performance No loss of stored data or user programmable functions

Where "operate as intended" or "no loss of function" is specified, the EUT shall demonstrate correct functioning as described in clause 5.

Where the EUT has more than one mode of operation (see clause 4.5.2), an unplanned transition from one mode to another is considered as an unintentional response. The EUT shall be tested in sufficient modes to confirm there are no such unintentional responses.



1.7 Measurement Uncertainty

Measurement uncertainty	
Parameter	Uncertainty
Uncertainty for Radiated Emission in 3m chamber	@30-200MHz $\pm 4.52\text{dB}$ @0.2-1GHz $\pm 5.56\text{dB}$ @1-6GHz $\pm 3.84\text{dB}$ @6-18GHz $\pm 3.92\text{dB}$
Uncertainty for Conducted Emission	@9-150kHz $\pm 3.74\text{dB}$ @0.15-30MHz $\pm 3.34\text{dB}$
Uncertainty for Harmonic test	3.26%
Uncertainty for Flicker test	4.76%
Uncertainty for RS test	21%, k=2
Uncertainty for CS test	29%, k=2
Uncertainty for ESD test	The immunity measurement system uncertainty is within standard requirement and is based on a standard uncertainty multiplied by a coverage factor k=2, providing a level of confidence of approximately 95%.
Uncertainty for EFT test	
Uncertainty for Surges test	
Uncertainty for Voltage Dips, Voltage Variations and Short Interruptions Test	
Uncertainty for PFMF test	



1.8 Test Equipment List and Details

Description	Manufacturer	Model	Serial Number	Cal Date	Due Date
Chamber A					
Spectrum Analyzer	Rohde & Schwarz	FSP	836079/035	2021-03-30	2022-03-29
EMI Test Receiver	Rohde & Schwarz	ESVB	825471/005	2021-04-12	2022-04-11
Amplifier	Agilent	8447F	3113A06717	2021-04-12	2022-04-11
Amplifier	C&D	PAP-1G18	2002	2021-04-12	2022-04-11
Trilog Broadband Antenna	Schwarz beck	VULB9163	9163-333	2021-03-20	2023-03-19
Horn Antenna	ETS	3117	00086197	2021-03-19	2023-03-18
Loop Antenna	Schwarz beck	FMZB 1516	9773	2021-03-20	2023-03-19
Chamber B					
Trilog Broadband Antenna	Schwarz beck	VULB9163(B)	9163-635	2021-04-09	2023-04-08
Amplifier	Agilent	8447D	2944A10179	2021-04-12	2022-04-11
EMI Test Receiver	Rohde & Schwarz	ESPI	101391	2021-04-27	2022-04-26
CE					
EMI Test Receiver	Rohde & Schwarz	ESPI	101611	2021-04-12	2022-04-11
Pulse Limiter	Rohde & Schwarz	ESH3-Z2	100911	2021-04-15	2022-04-14
AC LISN	Schwarz beck	NSLK8126	8126-224	2021-04-12	2022-04-11
8-WIRE LISN	Schwarz beck	8158	CAT3-8158-0059	2021-04-12	2022-04-11
8-WIRE LISN	Schwarz beck	8158	CAT5-8158-0117	2021-04-12	2022-04-11
EMF					
VDH Test Head	AFJ	VDH 30	SC022Z	2021-04-15	2022-04-14
3 Loop Antenna					
Loop Antenna	ZHINAN	ZN30401	19037	2021-04-26	2023-04-25
Clamp					
Clamp	Luthi	MDS21	3809	2021-04-16	2022-04-15
PFMF					
PMF Generator	LIONCEL	PMF-801C-C	0171101	2021-04-12	2022-04-11
PMF Antenna	LIONCEL	PMF-801C-A	0180302	2021-04-12	2022-04-11
Instantaneous PMF Generator Module	LIONCEL	PMF-801C-T	0171001	2021-04-12	2022-04-11
H/F					
Digital Power Analyzer	California Instrument	CTS	72831	2021-04-12	2022-04-11
Power Source	California Instrument	5001IX-CTS-400	25965	2021-04-12	2022-04-11
ESD					
ESD Generator	LIONCEL	ESD-203B	0170901	2021-04-16	2022-04-15
EFT/SURGE/DIPS					

Waltek Testing Group (Shenzhen) Co., Ltd.

[Http://www.waltek.com.cn](http://www.waltek.com.cn)



Transient 2000	EMC PARTNER	TRA2000	863	2021-04-12	2022-04-11
Couple Clamp	EMC PARTNER	CN-EFT1000	513	2021-04-12	2022-04-11
CS					
CONDUCTED IMMUNITY TEST SYSTEM	FRANKONIA	CIT-10/75	126B1247/2013	2021-01-08	2022-01-07
Attenuator	EMTEST	MA-5100/6BF2	1009	2021-03-30	2022-03-29
CDN	Luthi	L-801M2/M3	2665	2021-04-12	2022-04-11
EM Injection Clamp	FCC	F-203I-23mm	91536	2020-05-28	2021-05-27
RS					
Signal Generator	HP	8688B	3438A00604	2021-03-30	2022-03-29
Power Meter	KEITHLEY	3500	1162591	2021-03-27	2022-03-26
Power Meter	KEITHLEY	3500	1121428	2021-03-27	2022-03-26
RF Power Amplifier	MicoTop	MPA-80-1000-250	MPA1906239	2021-03-27	2022-03-26
RF Power Amplifier	MicoTop	MPA-80-1000-100	MPA1906238	2021-03-27	2022-03-26
Antenna	SCHWARZBECK	STLP 9129	9129 114	N/A	N/A

Software List			
Description	Manufacturer	Model	Version
EMI Test Software (Radiated Emission)*	Farad	EZ-EMC	RA-03A1
EMI Test Software (Conducted Emission)*	Farad	EZ-EMC	RA-03A1

*Remark: indicates software version used in the compliance certification testing.



2. SUMMARY OF TEST RESULTS

Standards	Reference	Description of Test Item	Result
ETSI EN 301 489-1	8.2	Radiated Emissions	Pass
	8.3	Conducted Emissions for DC Power Port	N/A
	8.4	Conducted Emissions for AC Power Port	Pass
	8.5	Harmonic Current Emissions	N/A
	8.6	Voltage Fluctuations and Flicker	Pass
	8.7	Telecommunication Ports	N/A
	9.2	Radio Frequency Electromagnetic Field	Pass
	9.3	Electrostatic Discharge	Pass
	9.4	Fast Transients, Common Mode	Pass
	9.5	Radio Frequency, Common Mode	Pass
	9.6	Transient and Surges in the Vehicular Environment	N/A
	9.7	Voltage Dips and Interruptions	Pass
	9.8	Surges	Pass

Pass: The EUT complies with the essential requirements in the standard.

Fail: The EUT does not comply with the essential requirements in the standard.

N/A: Not applicable.



3. Conducted Emissions

3.1 Test Procedure

Test is conducting under the description of EN55032 Information technology equipment - Radio disturbance characteristics - Limits and methods of measurement.

3.2 Basic Test Setup Block Diagram

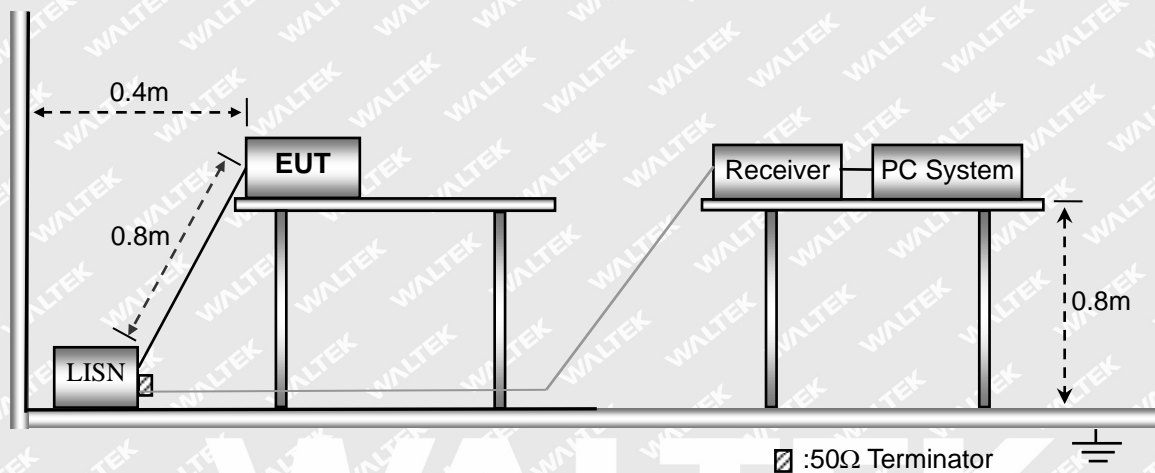

3.3 Environmental Conditions

Temperature:	23.5° C
Relative Humidity:	54 %
ATM Pressure:	1015 mbar

3.4 Conducted Emissions Test Data

Note: Only show the worst case in the test report.



Test mode:	TM1	Polarity:	Neutral
------------	-----	-----------	---------

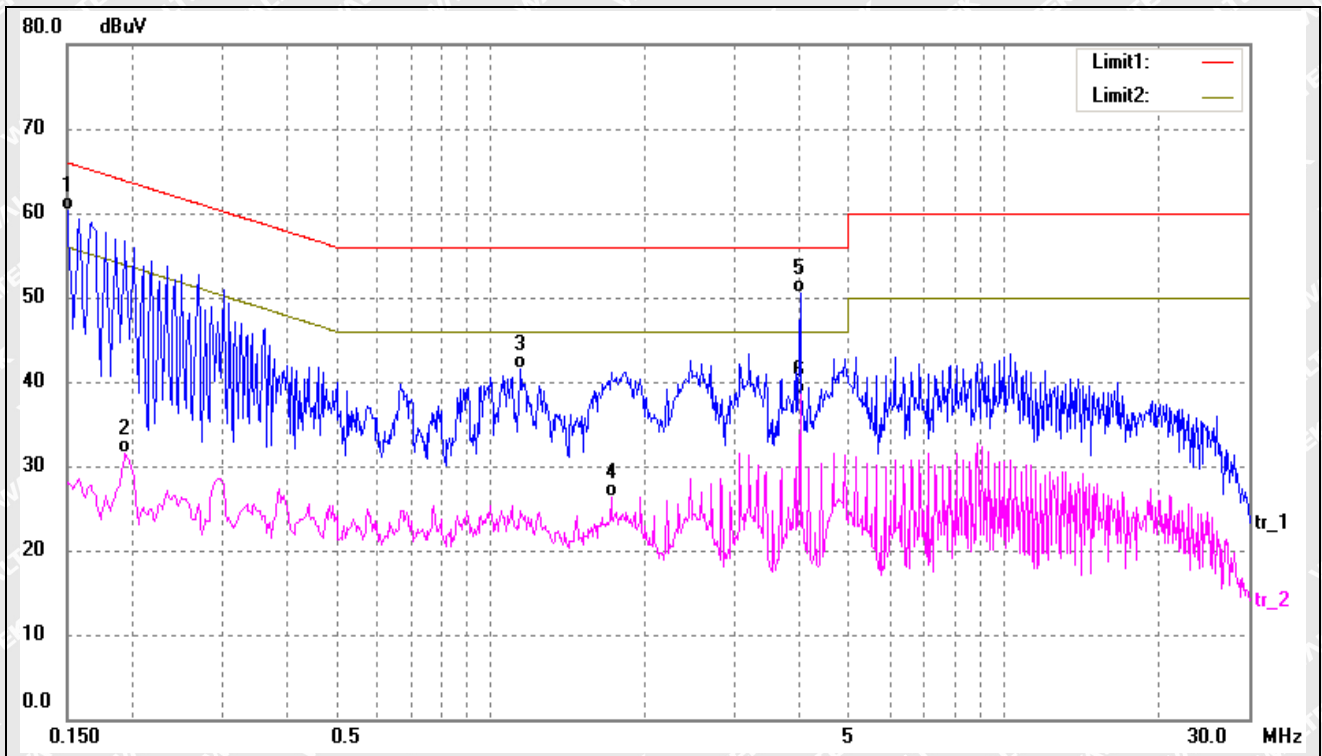

No.	Frequency (MHz)	Reading (dBuV)	Correct (dB)	Result (dBuV)	Limit (dBuV)	Margin (dB)	Detector
1	0.1500	49.87	10.38	60.25	66.00	-5.75	QP
2	0.1940	21.18	10.37	31.55	53.86	-22.31	AVG
3	1.1460	30.95	10.50	41.45	56.00	-14.55	QP
4	1.7180	16.13	10.25	26.38	46.00	-19.62	AVG
5*	4.0140	40.51	10.04	50.55	56.00	-5.45	QP
6	4.0140	28.38	10.04	38.42	46.00	-7.58	AVG



Test mode:	TM1	Polarity:	Line
------------	-----	-----------	------

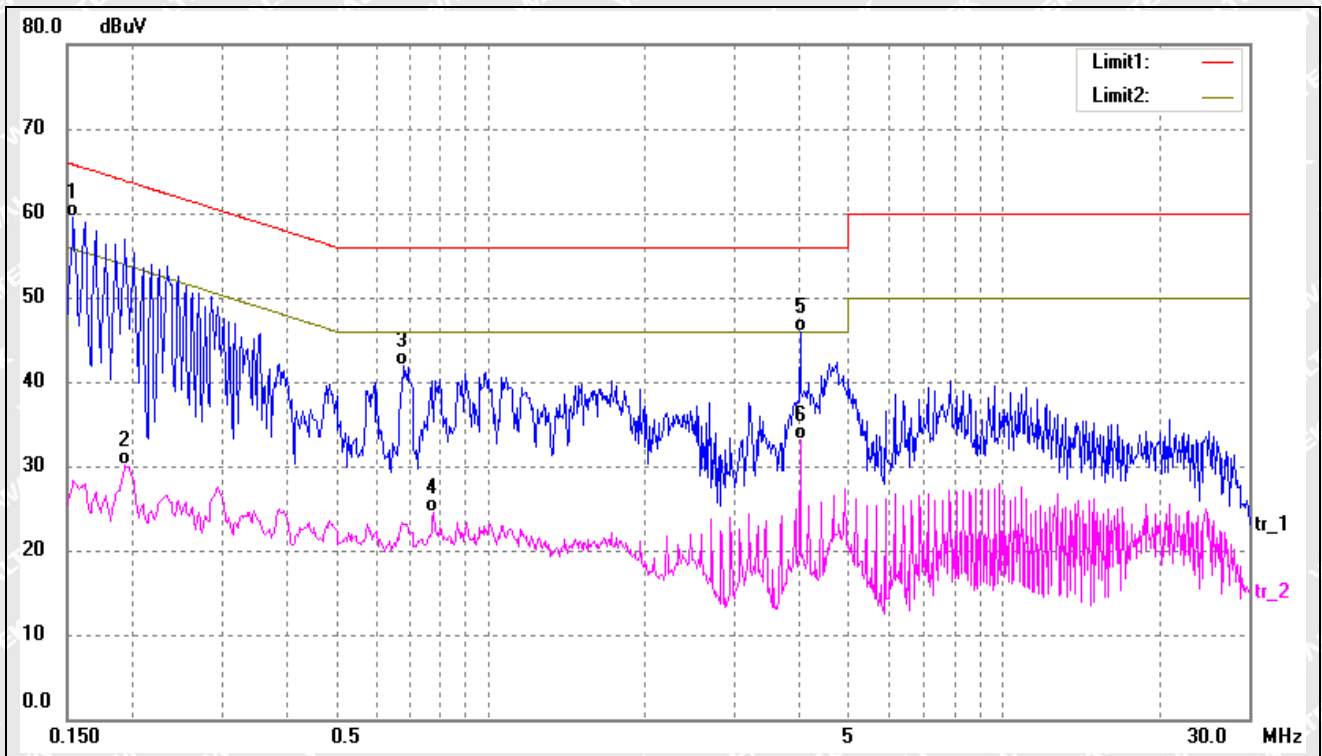

No.	Frequency (MHz)	Reading (dBuV)	Correct (dB)	Result (dBuV)	Limit (dBuV)	Margin (dB)	Detector
1*	0.1539	49.10	10.37	59.47	65.78	-6.31	QP
2	0.1940	19.65	10.37	30.02	53.86	-23.84	AVG
3	0.6820	31.49	10.37	41.86	56.00	-14.14	QP
4	0.7780	14.06	10.43	24.49	46.00	-21.51	AVG
5	4.0140	35.88	10.04	45.92	56.00	-10.08	QP
6	4.0140	23.03	10.04	33.07	46.00	-12.93	AVG



Test mode:	TM2	Polarity:	Neutral
------------	-----	-----------	---------

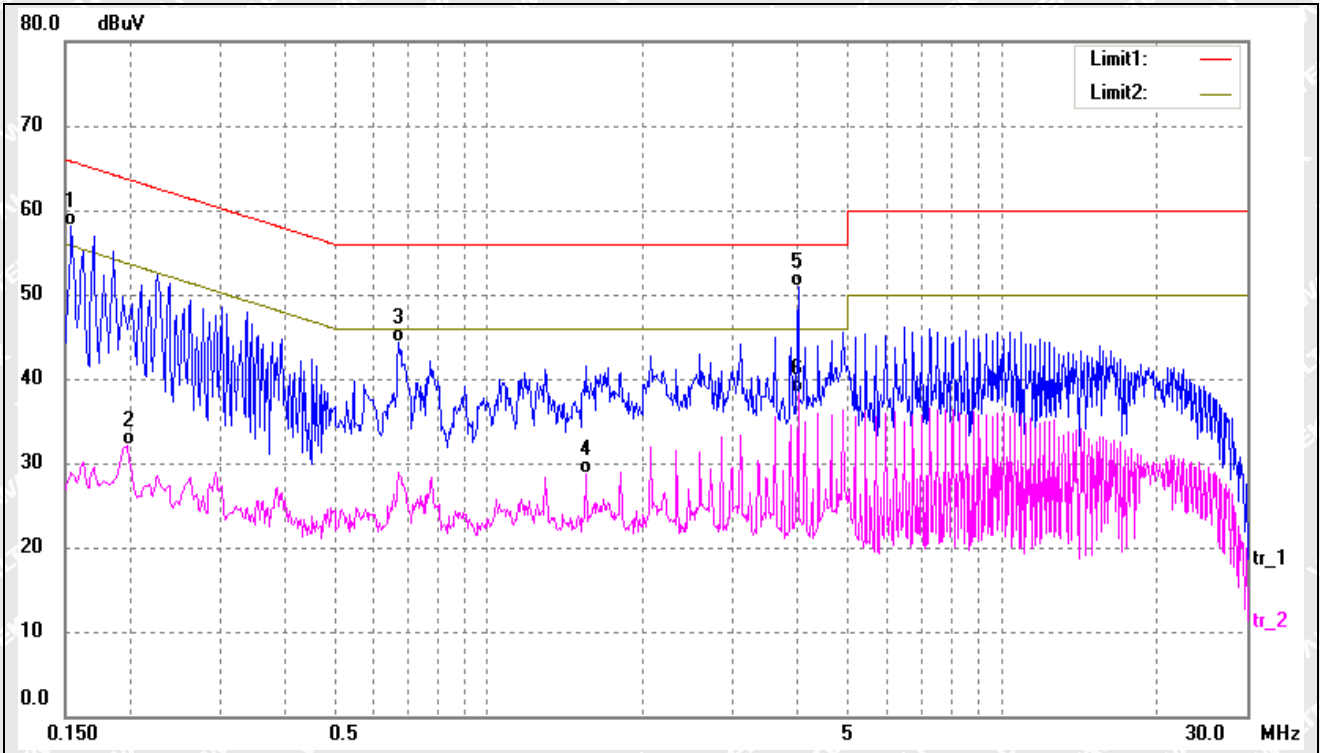

No.	Frequency (MHz)	Reading (dBuV)	Correct (dB)	Result (dBuV)	Limit (dBuV)	Margin (dB)	Detector
1	0.1540	47.68	10.37	58.05	65.78	-7.73	QP
2	0.1980	21.66	10.37	32.03	53.69	-21.66	AVG
3	0.6700	33.89	10.36	44.25	56.00	-11.75	QP
4	1.5500	18.34	10.32	28.66	46.00	-17.34	AVG
5*	4.0140	40.88	10.04	50.92	56.00	-5.08	QP
6	4.0140	28.36	10.04	38.40	46.00	-7.60	AVG



Test mode:	TM2	Polarity:	Line
------------	-----	-----------	------

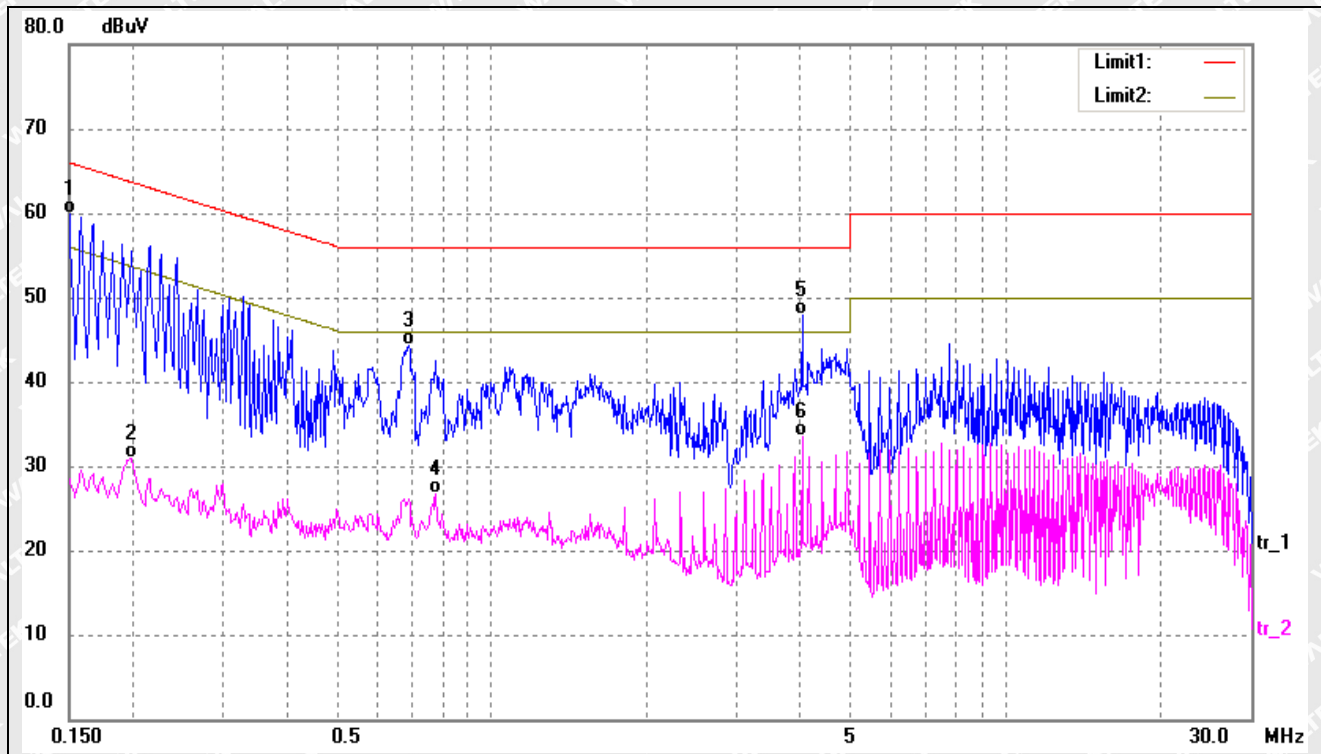

No.	Frequency (MHz)	Reading (dBuV)	Correct (dB)	Result (dBuV)	Limit (dBuV)	Margin (dB)	Detector
1*	0.1500	49.48	10.38	59.86	66.00	-6.14	QP
2	0.1980	20.59	10.37	30.96	53.69	-22.73	AVG
3	0.6860	33.94	10.37	44.31	56.00	-11.69	QP
4	0.7780	16.25	10.43	26.68	46.00	-19.32	AVG
5	4.0180	37.78	10.04	47.82	56.00	-8.18	QP
6	4.0180	23.40	10.04	33.44	46.00	-12.56	AVG



Test mode:	TM3	Polarity:	Neutral
------------	-----	-----------	---------

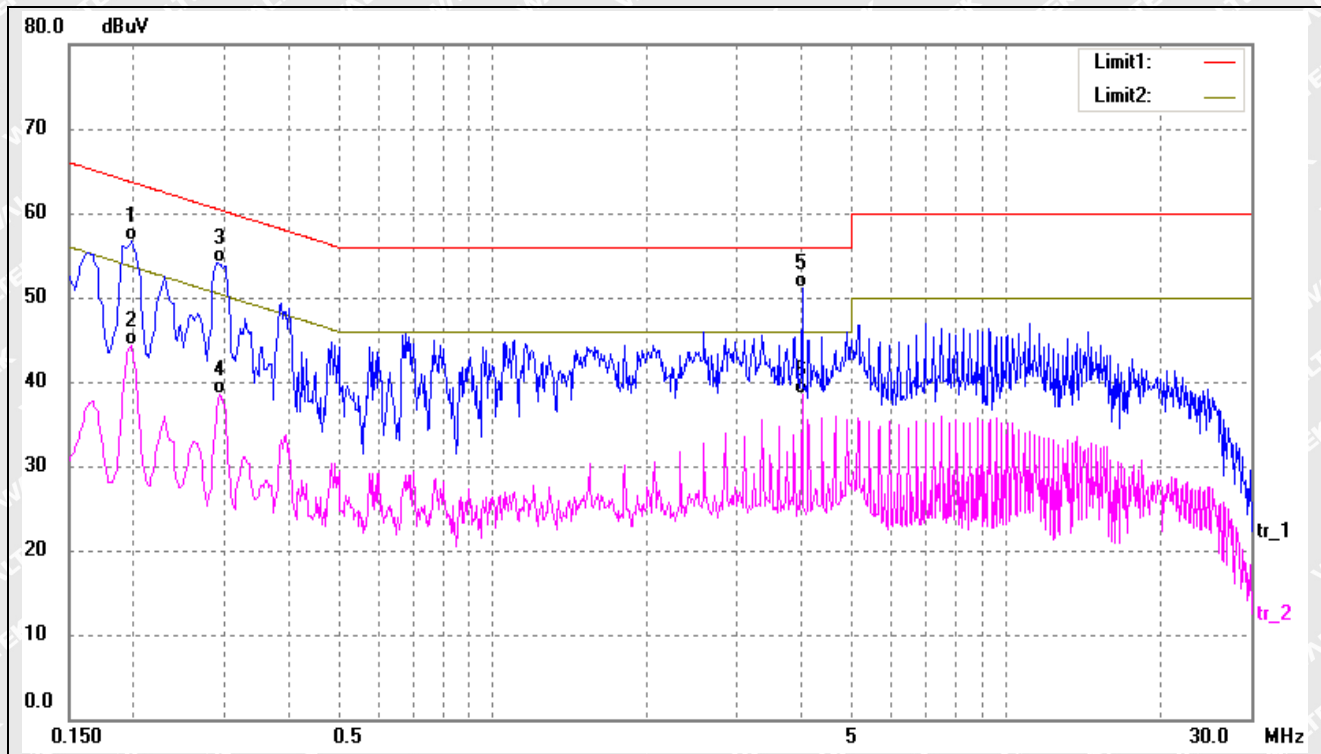

No.	Frequency (MHz)	Reading (dBuV)	Correct (dB)	Result (dBuV)	Limit (dBuV)	Margin (dB)	Detector
1	0.1980	46.29	10.37	56.66	63.69	-7.03	QP
2	0.1980	33.99	10.37	44.36	53.69	-9.33	AVG
3	0.2900	43.82	10.34	54.16	60.52	-6.36	QP
4	0.2940	28.16	10.34	38.50	50.41	-11.91	AVG
5*	4.0180	41.06	10.04	51.10	56.00	-4.90	QP
6	4.0180	28.52	10.04	38.56	46.00	-7.44	AVG



Test mode:	TM3	Polarity:	Line
------------	-----	-----------	------

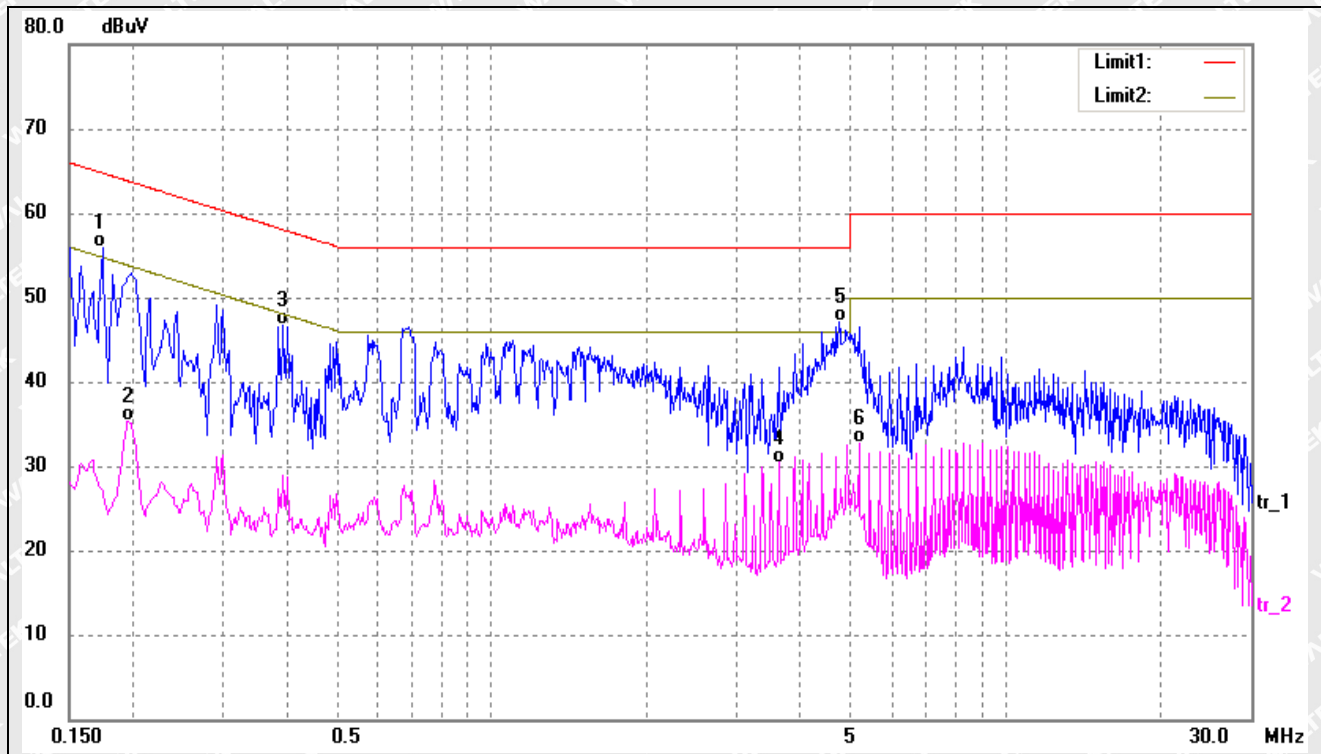

No.	Frequency (MHz)	Reading (dBuV)	Correct (dB)	Result (dBuV)	Limit (dBuV)	Margin (dB)	Detector
1*	0.1740	45.51	10.37	55.88	64.77	-8.89	QP
2	0.1940	24.88	10.37	35.25	53.86	-18.61	AVG
3	0.3900	36.43	10.30	46.73	58.06	-11.33	QP
4	3.6220	20.34	10.06	30.40	46.00	-15.60	AVG
5	4.7300	37.01	10.01	47.02	56.00	-8.98	QP
6	5.1740	22.72	10.00	32.72	50.00	-17.28	AVG



4. Radiated Emissions

4.2 Test Procedure

Test is conducting under the description of EN55032 Information technology equipment - Radio disturbance characteristics - Limits and methods of measurement.

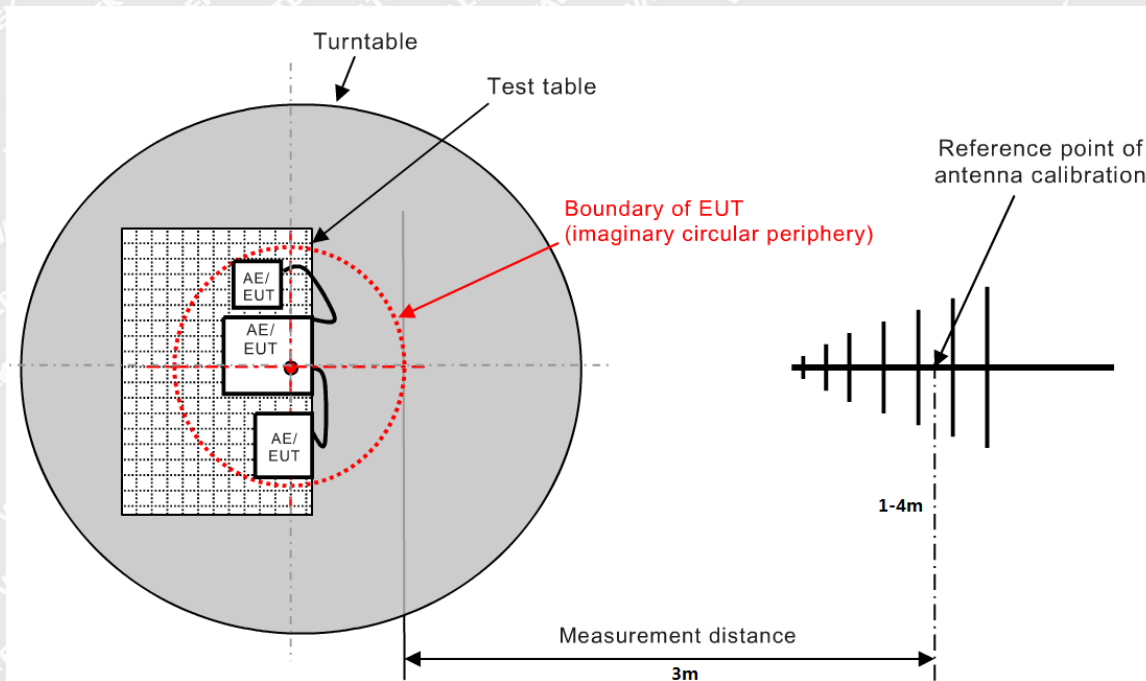

4.2 Corrected Amplitude & Margin Calculation

The Corrected Amplitude is calculated by adding the Antenna Factor and the Cable Factor, and subtracting the Amplifier Gain from the Amplitude reading. The basic equation is as follows:

$$\text{Corr. Ampl.} = \text{Indicated Reading} + \text{Antenna Factor} + \text{Cable Factor} - \text{Amplifier Gain}$$

The “**Margin**” column of the following data tables indicates the degree of compliance with the applicable limit. For example, a margin of $-6\text{dB}\mu\text{V}$ means the emission is $6\text{dB}\mu\text{V}$ below the maximum limit for Class B device. The equation for margin calculation is as follows:

$$\text{Margin} = \text{Corr. Ampl.} - \text{EN 301489 Class B Limit}$$



4.3 Environmental Conditions

Temperature:	22.5° C
Relative Humidity:	54%
ATM Pressure:	1011 mbar

4.4 Summary of Test Results/Plots

Note: Only show the worst case in the test report

➤ 30MHz to 1GHz

Test mode:	TM1	Polarity:	Horizontal
------------	-----	-----------	------------

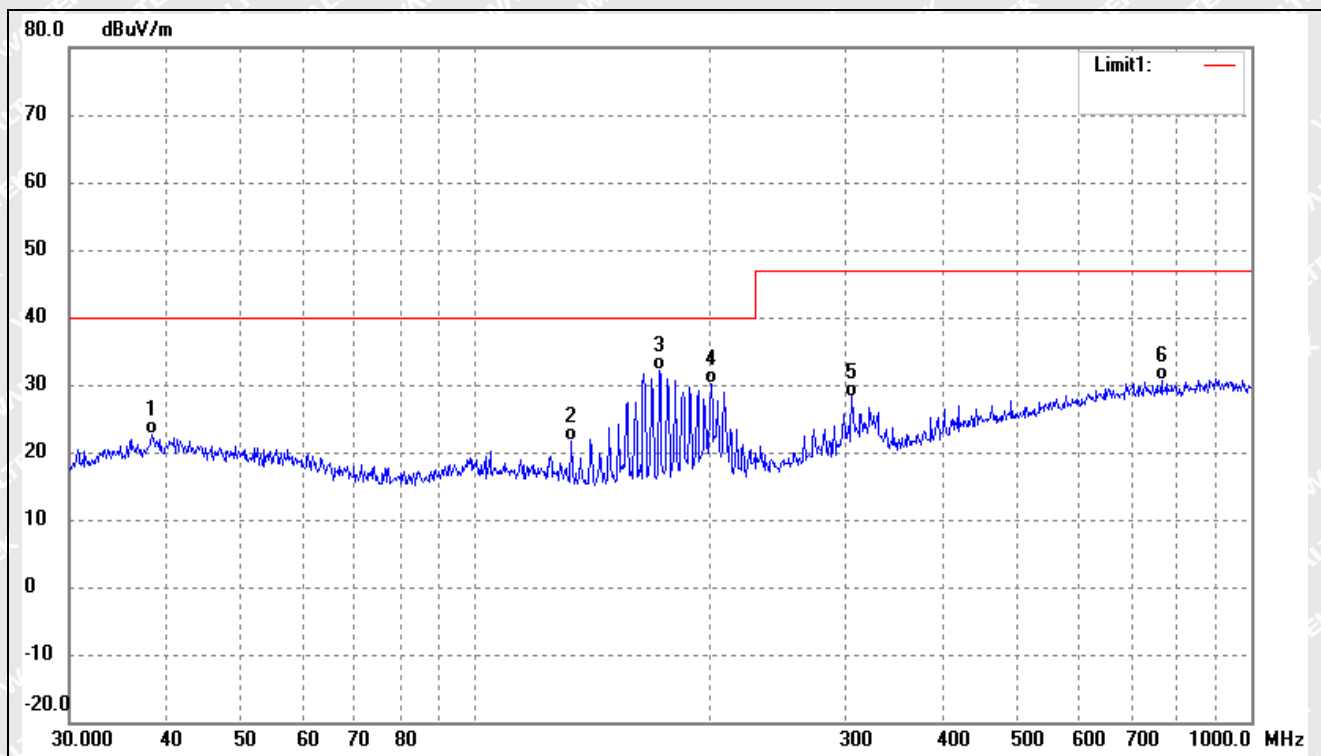

No.	Frequency (MHz)	Reading (dBuV/m)	Correct (dB/m)	Result (dBuV/m)	Limit (dBuV/m)	Margin (dB)	Degree ()	Height (cm)	Remark
1	38.3462	29.97	-7.40	22.57	40.00	-17.43	-	-	QP
2	133.1511	33.27	-11.69	21.58	40.00	-18.42	-	-	QP
3	172.5988	43.76	-11.61	32.15	40.00	-7.85	-	-	QP
4	201.3930	39.82	-9.66	30.16	40.00	-9.84	-	-	QP
5	305.6800	35.04	-6.79	28.25	47.00	-18.75	-	-	QP
6	766.0572	28.72	1.87	30.59	47.00	-16.41	-	-	QP



Test mode:	TM1	Polarity:	Vertical
------------	-----	-----------	----------

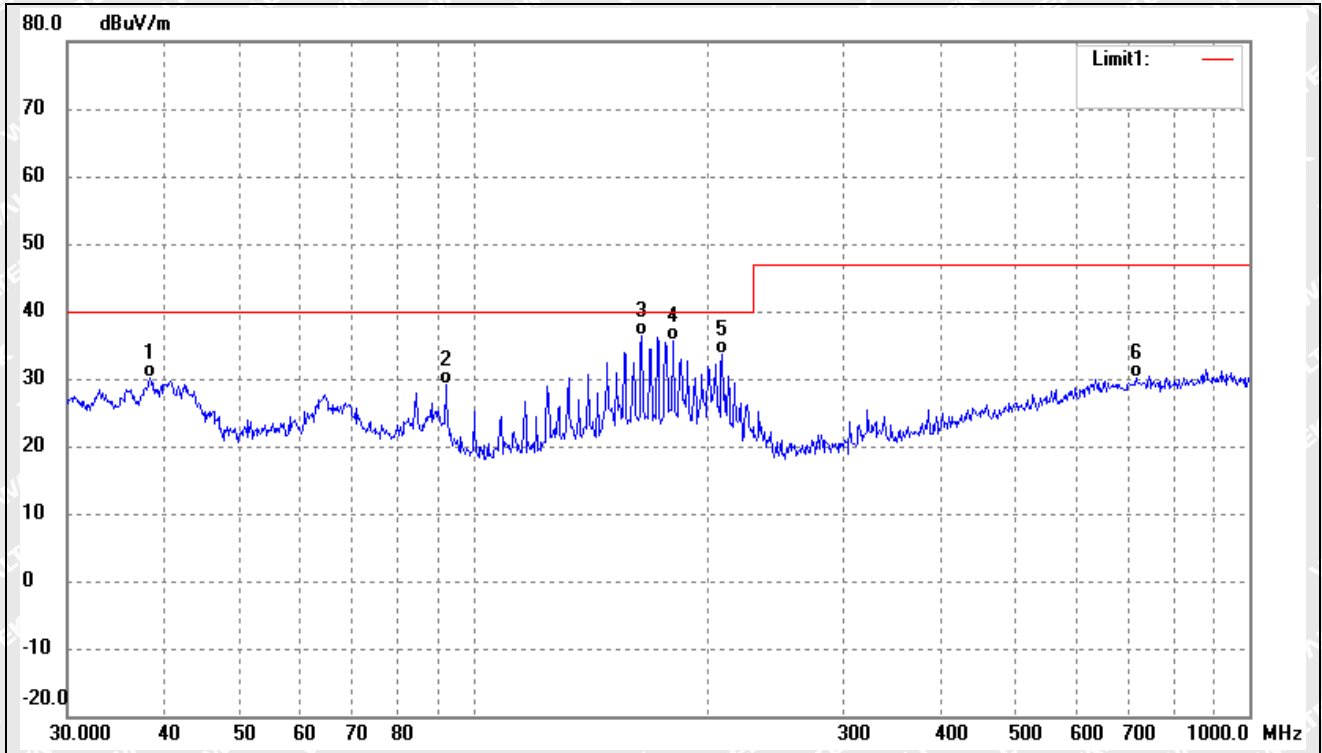

No.	Frequency (MHz)	Reading (dBuV/m)	Correct (dB/m)	Result (dBuV/m)	Limit (dBuV/m)	Margin (dB)	Degree ()	Height (cm)	Remark
1	38.3462	37.53	-7.40	30.13	40.00	-9.87	-	-	QP
2	92.1388	39.19	-10.18	29.01	40.00	-10.99	-	-	QP
3	164.9075	48.28	-11.94	36.34	40.00	-3.66	-	-	QP
4	180.6488	46.94	-11.20	35.74	40.00	-4.26	-	-	QP
5	209.3129	42.99	-9.44	33.55	40.00	-6.45	-	-	QP
6	714.1734	28.59	1.52	30.11	47.00	-16.89	-	-	QP



Test mode:	TM2	Polarity:	Horizontal
------------	-----	-----------	------------

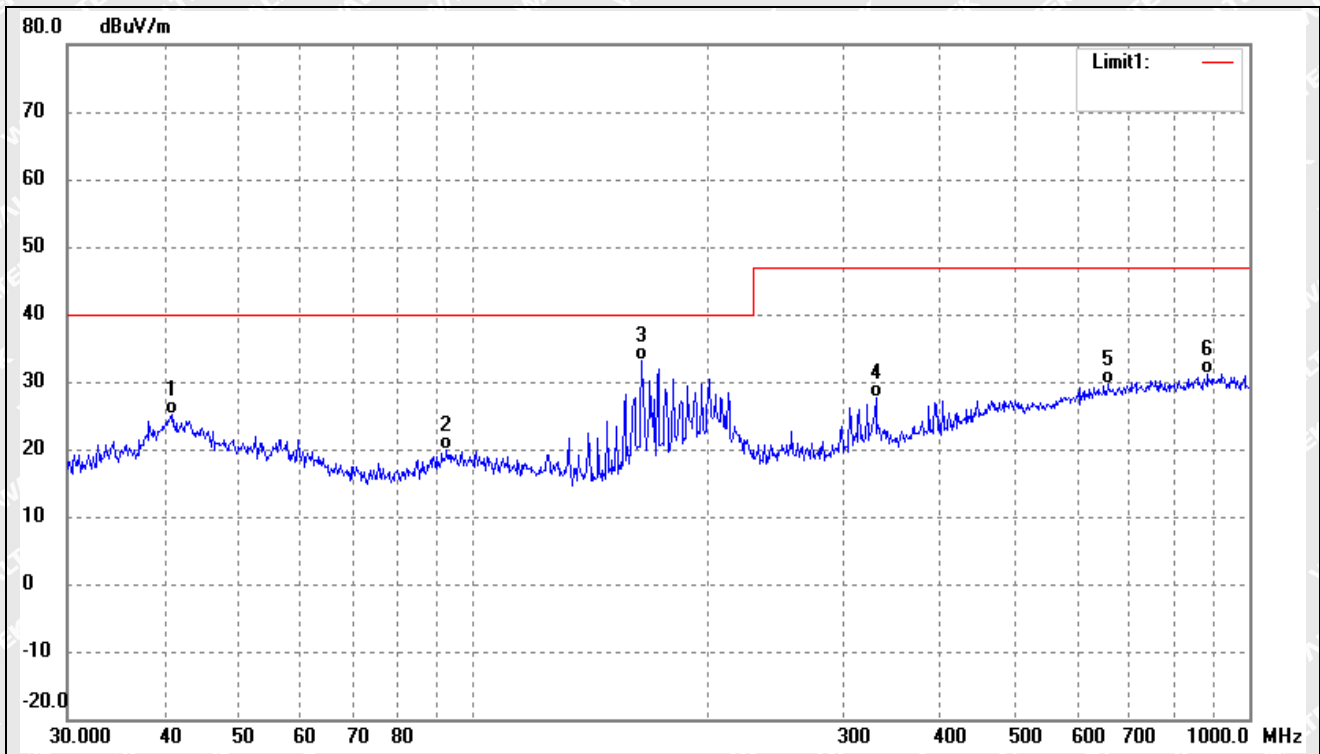

No.	Frequency (MHz)	Reading (dBuV/m)	Correct dB/m	Result (dBuV/m)	Limit (dBuV/m)	Margin (dB)	Degree ()	Height (cm)	Remark
1	40.9881	32.18	-7.00	25.18	40.00	-14.82	-	-	QP
2	92.4624	30.07	-10.13	19.94	40.00	-20.06	-	-	QP
3	164.9075	45.10	-11.94	33.16	40.00	-6.84	-	-	QP
4	330.1949	33.57	-6.02	27.55	47.00	-19.45	-	-	QP
5	658.8362	28.59	1.01	29.60	47.00	-17.40	-	-	QP
6	884.5029	28.61	2.63	31.24	47.00	-15.76	-	-	QP



Test mode:	TM2	Polarity:	Vertical
------------	-----	-----------	----------

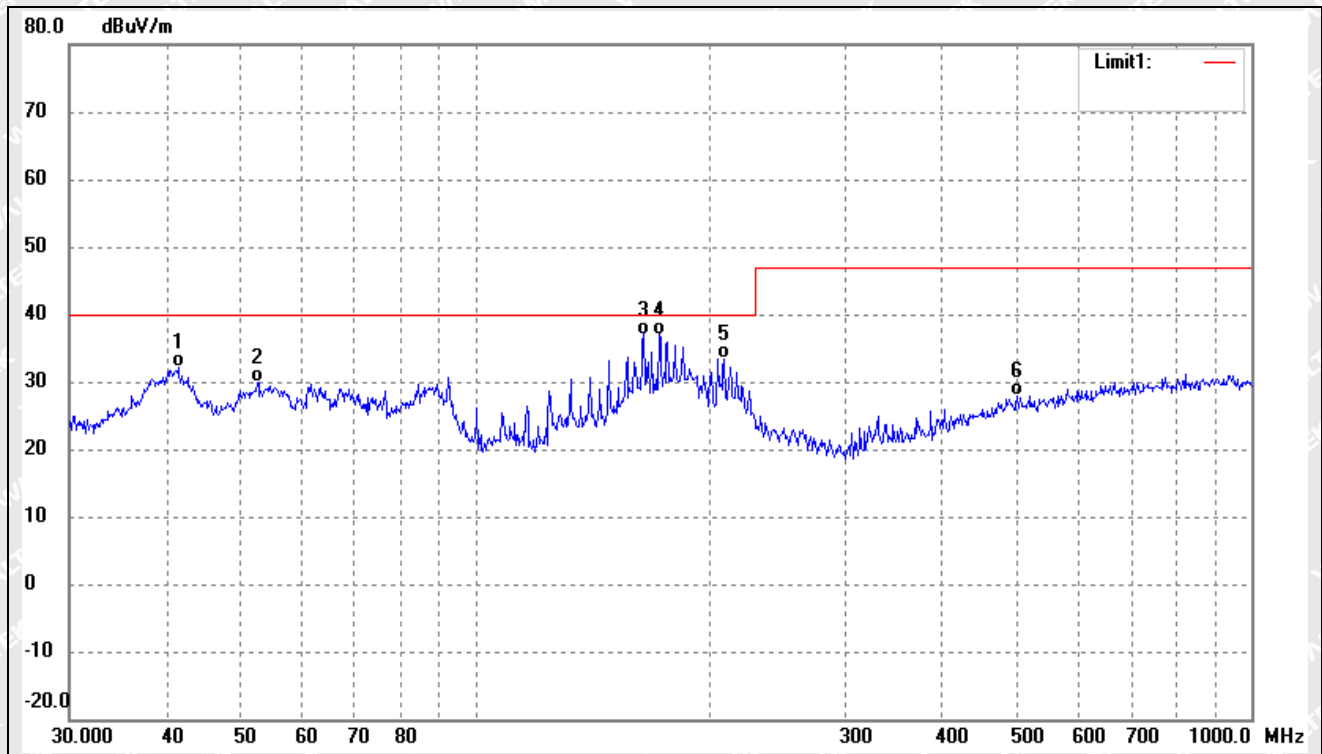

No.	Frequency (MHz)	Reading (dBuV/m)	Correct dB/m	Result (dBuV/m)	Limit (dBuV/m)	Margin (dB)	Degree ()	Height (cm)	Remark
1	41.4215	39.06	-6.99	32.07	40.00	-7.93	-	-	QP
2	52.3913	37.30	-7.31	29.99	40.00	-10.01	-	-	QP
3	164.9075	48.92	-11.94	36.98	40.00	-3.02	-	-	QP
4	172.5988	48.60	-11.61	36.99	40.00	-3.01	-	-	QP
5	209.3129	42.81	-9.44	33.37	40.00	-6.63	-	-	QP
6	499.4247	29.31	-1.31	28.00	47.00	-19.00	-	-	QP



Test mode:	TM3	Polarity:	Horizontal
------------	-----	-----------	------------

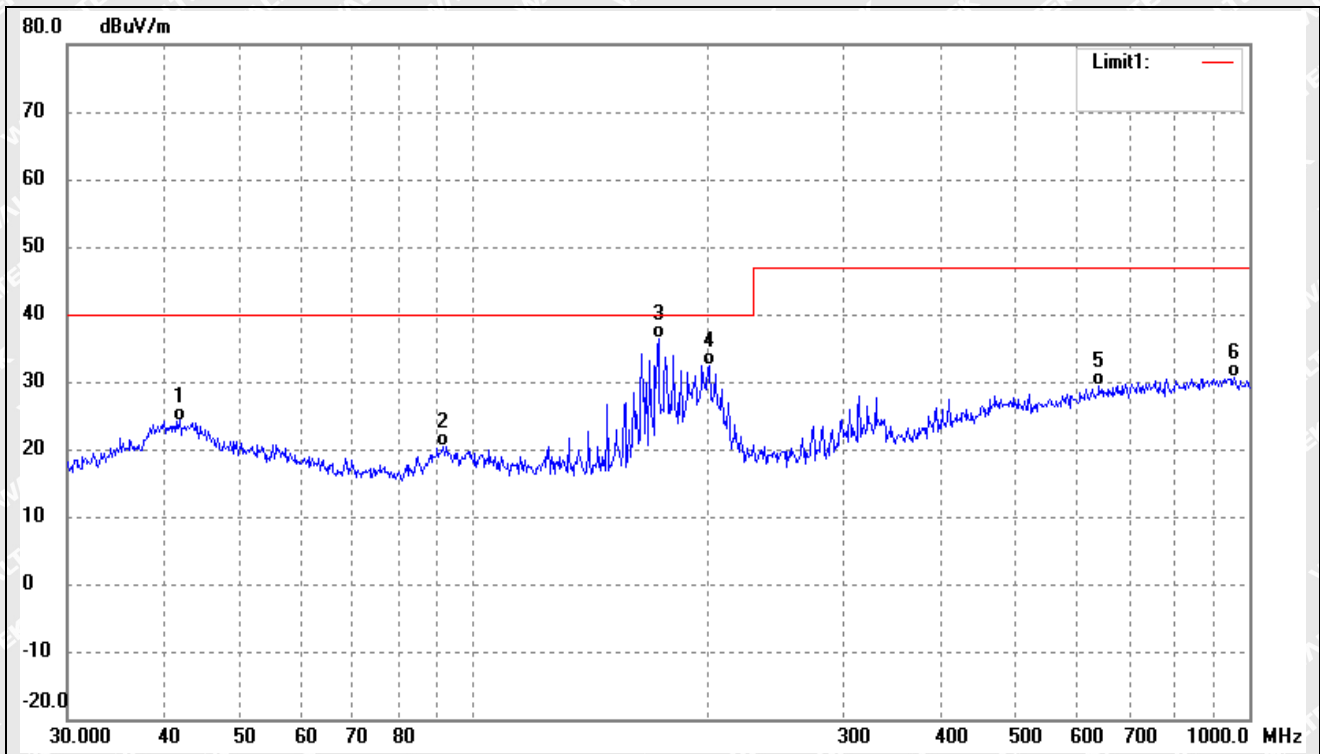

No.	Frequency (MHz)	Reading (dBuV/m)	Correct dB/m	Result (dBuV/m)	Limit (dBuV/m)	Margin (dB)	Degree ()	Height (cm)	Remark
1	41.8596	31.24	-6.99	24.25	40.00	-15.75	-	-	QP
2	91.4949	30.73	-10.31	20.42	40.00	-19.58	-	-	QP
3	173.2051	47.93	-11.58	36.35	40.00	-3.65	-	-	QP
4	201.3930	41.96	-9.66	32.30	40.00	-7.70	-	-	QP
5	640.6110	28.51	0.82	29.33	47.00	-17.67	-	-	QP
6	955.4381	27.98	2.57	30.55	47.00	-16.45	-	-	QP



Test mode:	TM3	Polarity:	Vertical
------------	-----	-----------	----------

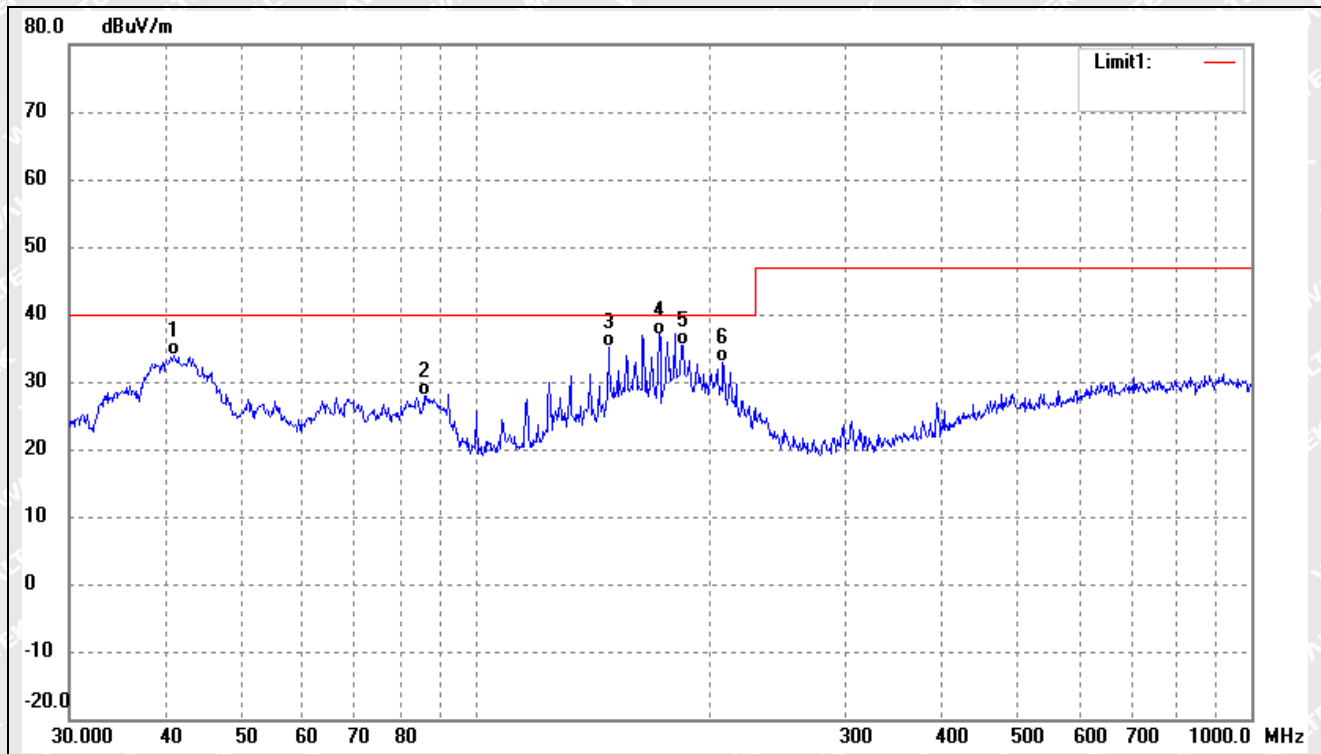

No.	Frequency (MHz)	Reading (dBuV/m)	Correct dB/m	Result (dBuV/m)	Limit (dBuV/m)	Margin (dB)	Degree ()	Height (cm)	Remark
1	40.8446	40.99	-7.00	33.99	40.00	-6.01	-	-	QP
2	85.8984	38.45	-10.64	27.81	40.00	-12.19	-	-	QP
3	148.4410	47.69	-12.55	35.14	40.00	-4.86	-	-	QP
4	172.5988	48.54	-11.61	36.93	40.00	-3.07	-	-	QP
5	185.1379	46.08	-10.64	35.44	40.00	-4.56	-	-	QP
6	208.5803	42.34	-9.46	32.88	40.00	-7.12	-	-	QP

Remark: '-' Means 'the test Degree and Height are not recorded by the test software and only show the worst case in the test report.'



5. Harmonic Current Emissions

5.1 Test Procedure

Test is conducting under the description of EN 61000-3-2.

5.2 Test Setup Block Diagram

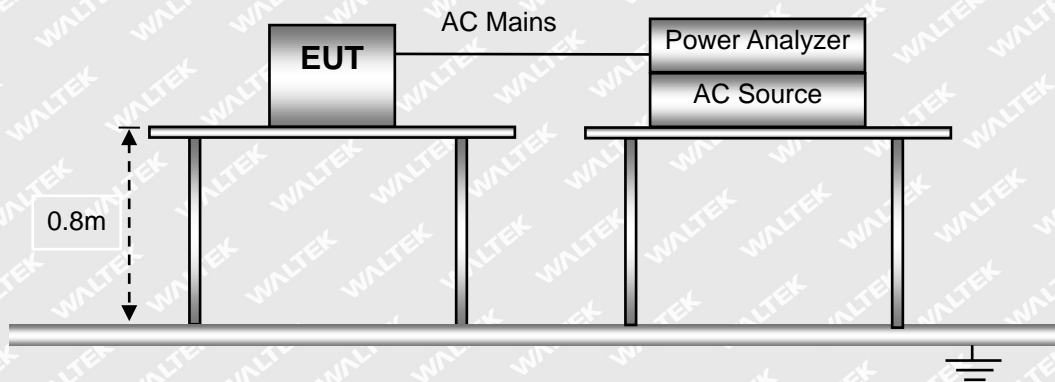

5.3 Test Standards

EN61000-3-2, Clause 7.1 Limits for Class A equipment.

5.4 Environmental Conditions

Temperature:	26 °C
Relative Humidity:	55%
ATM Pressure:	1015 mbar

5.5 Harmonic Current Emissions Test Data

According to Clause 7 of EN61000-3-2, the EUT rated power is less than 75W, belong to 'equipment with a rated power of 75W or less', therefore 'limits are not specified in this edition of the standards'. It is deemed to fully fit the requirements of the standards.

Result: The EUT complies with the requirements of this section.



6. Voltage Fluctuation and Flicker

6.1 Test Procedure

Test is conducting under the description of EN 61000-3-3.

6.2 Test Setup Block Diagram

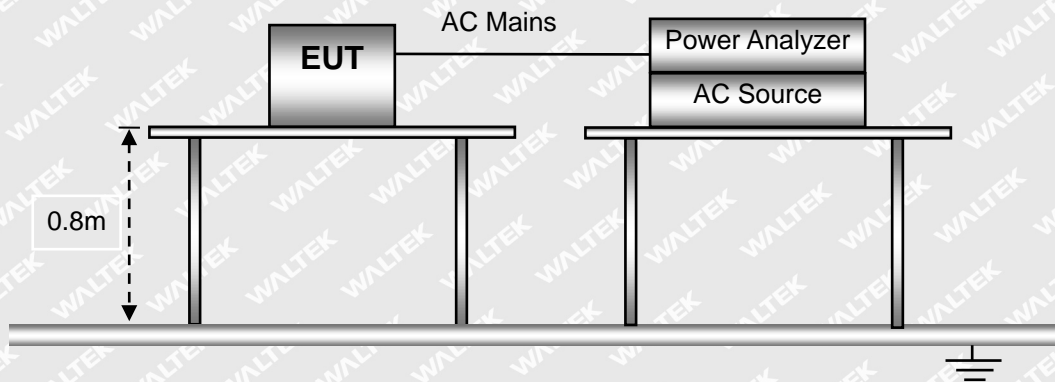

6.3 Test Standards

EN61000-3-3, Limit: Clause 5.

6.4 Environmental Conditions

Temperature:	26 °C
Relative Humidity:	55%
ATM Pressure:	1015 mbar

6.5 Voltage Fluctuation and Flicker Test Data

Result: The EUT is compliance with the requirements of this section.



Test mode:	TM1
------------	-----

Test Result: Pass

Status: Test Completed

Pst_i and limit line

European Limits

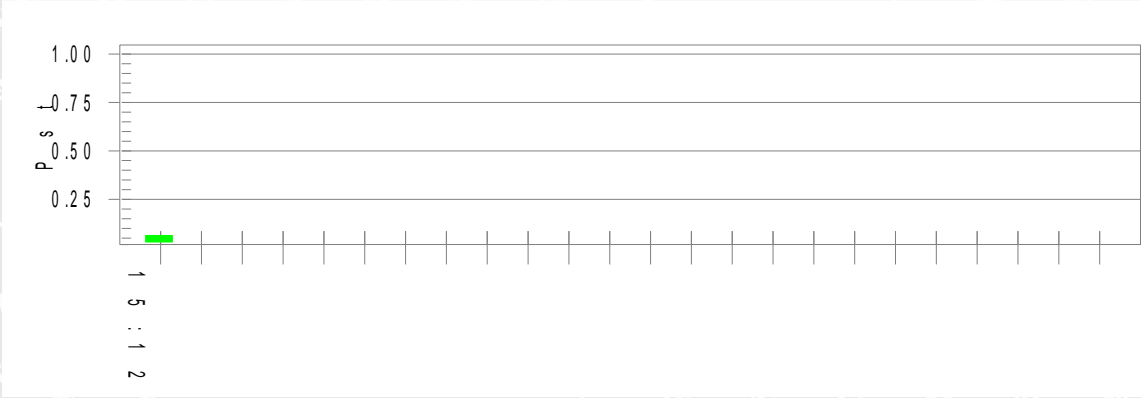

Plt and limit line



Parameter values recorded during the test:

Vrms at the end of test (Volt):	229.99			
T-max (mS):	0	Test limit (mS):	500.0	Pass
Highest dc (%):	0.00	Test limit (%):	3.30	Pass
Highest dmax (%):	0.00	Test limit (%):	4.00	Pass
Highest Pst (10 min. period):	0.064	Test limit:	1.000	Pass
Highest Plt (2 hr. period):	0.028	Test limit:	0.650	Pass



Test mode	TM1-TM4							
EN 61000-4-2 Test Points	Test Levels (kV)							
	-2	+2	-4	+4	-6	+6	-8	+8
Air Discharge								
USB Port	A	A	A	A	A	A	B	B
Enclosure	A	A	A	A	A	A	B	B
Direct Contact Discharge								
/	/	/	/	/	/	/	/	/
Indirect Contact Discharge								
HCP (6 Sides)	A	A	B	B	/	/	/	/
VCP (4 Sides)	A	A	B	B	/	/	/	/

Test Result: Pass

WALTEK



8. Radio Frequency Electromagnetic Field (R/S)

8.1 Test Procedure

Test is conducting under the description of EN 61000-4-3.

8.2 Test Setup Block Diagram

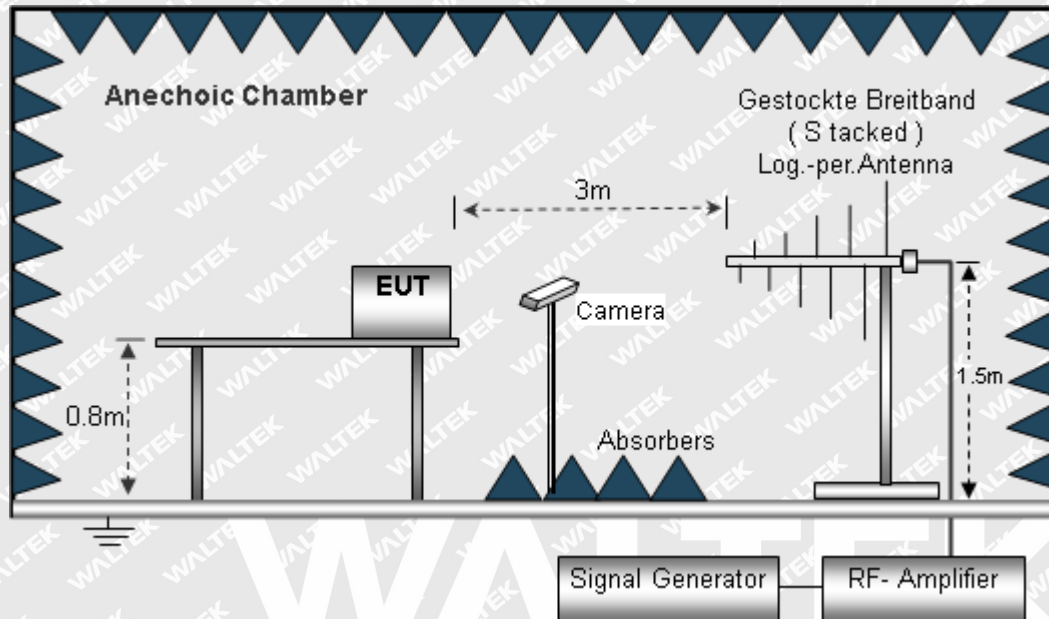

8.3 Test Performance

Performance Criterion:	Mode	Verdict
		TM1-TM4

Note: TM4 for CT,CR

8.4 Environmental Conditions

Temperature:	25 °C
Relative Humidity:	52%
ATM Pressure:	1010 mbar

8.5 Continuous Radiated Disturbances Test Data

Frequency step: 1% of fundamental

Dwell time: 1 second

Modulation: AM by 1kHz sine wave with 80% modulation depth



Test mode		TM1-TM4							
Frequency Range(MHz)	Field (V/m)	Front		Rear		Left Side		Right Side	
		VERT	HORI	VERT	HORI	VERT	HORI	VERT	HORI
80-1000	3	A	A	A	A	A	A	A	A
1000-3000	3	A	A	A	A	A	A	A	A
3000-6000	3	A	A	A	A	A	A	A	A

Test Result: Pass

WALTEK



9. Fast Transients, Common Mode (EFT)

9.1 Test Procedure

Test is conducting under the description of EN 61000-4-4.

9.2 Test Setup Block Diagram

For AC Mains or DC Ports:

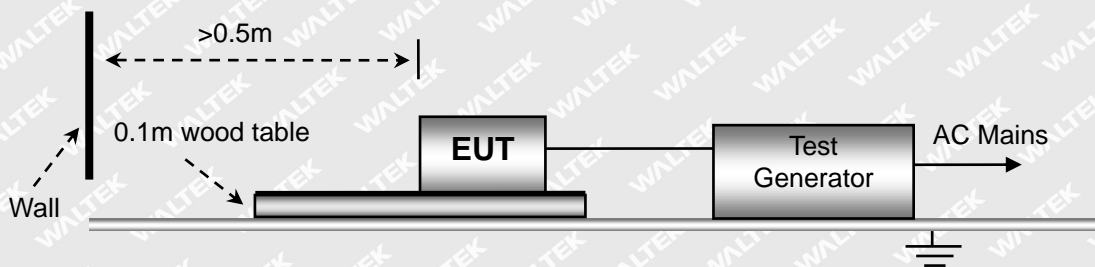

For Signal or Telecommunication Ports:

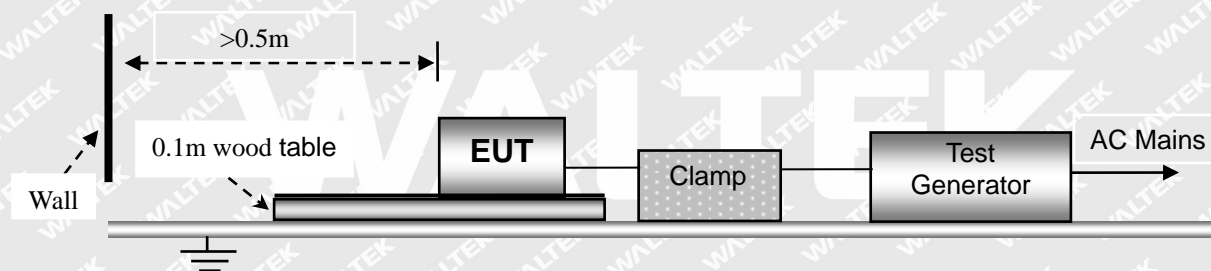

9.3 Test Performance

Performance Criterion:	Mode	Verdict
		TM1-TM4

Note: TM4 for TT,TR

9.4 Environmental Conditions

Temperature:	22 °C
Relative Humidity:	53%
ATM Pressure:	1011 mbar

9.5 Electrical Fast Transients Test Data



Test Mode		TM1-TM4							
EN 61000-4-4 Test Line		Test Levels (kV)							
		+0.5	-0.5	+1.0	-1.0	+2.0	-2.0	+4.0	-4.0
AC Main Power port	L	A	A	A	A	/	/	/	/
	N	A	A	A	A	/	/	/	/
	PE	/	/	/	/	/	/	/	/
	L-N	A	A	A	A	/	/	/	/
	L-PE	/	/	/	/	/	/	/	/
	N-PE	/	/	/	/	/	/	/	/
	L-N-PE	/	/	/	/	/	/	/	/
Signal ports	/	/	/	/	/	/	/	/	

Test Result: Pass

WALTEK



10. Surges

10.1 Test Procedure

Test is conducting under the description of EN 61000-4-5.

10.2 Test Setup Block Diagram

For AC Mains or DC Ports:

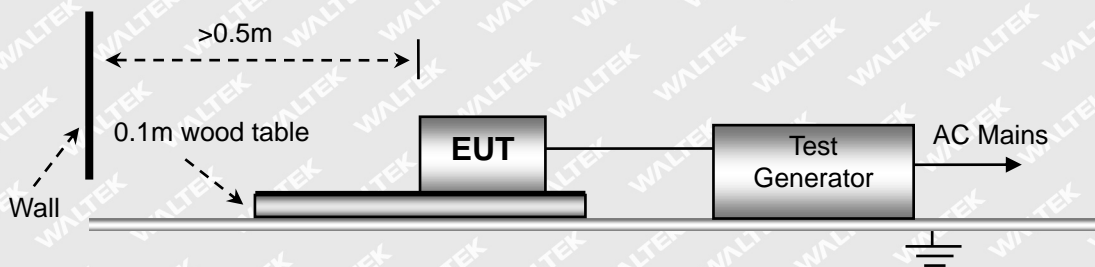

For Signal or Telecommunication Ports:

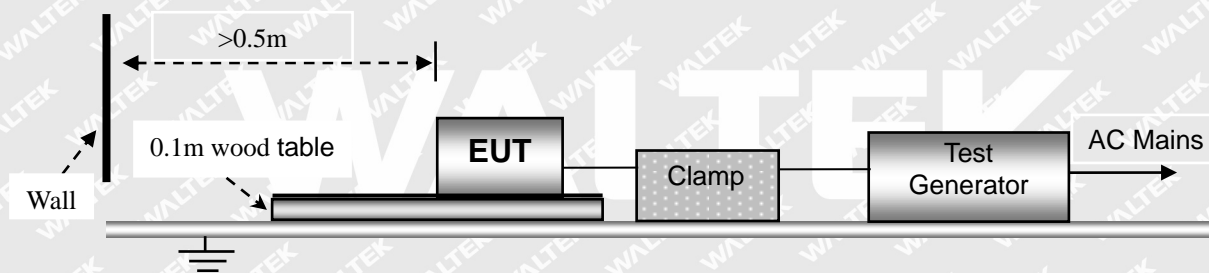

10.3 Test Performance

Performance Criterion:	Mode	Verdict
		TM1-TM4

Note: TM4 for TT,TR

10.4 Environmental Conditions

Temperature:	25 °C
Relative Humidity:	53%
ATM Pressure:	1011 mbar

10.5 Surge Test Data



Test Mode	TM1-TM4			
Voltage	Poll	Path	Pass	Fail
0.5kV	±	L-N	A	/
1kV	±	L-N	A	/
2kV	±	L-N, L-PE, N-PE	/	/
4kV	±	L-N, L-PE, N-PE	/	/

Test Result: Pass

WALTEK



11. Radio Frequency, Common Mode (C/S)

11.1 Test Procedure

Test is conducting under the description of EN 61000-4-6.

11.2 Test Setup Block Diagram

For AC Mains or DC Input:

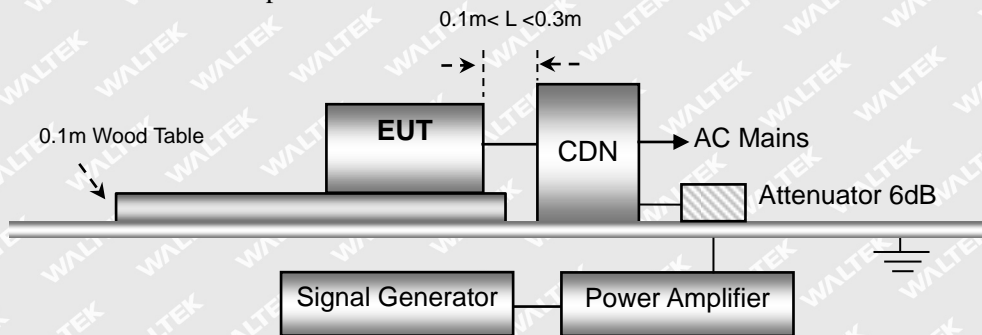

For Signal or Telecommunication Ports:

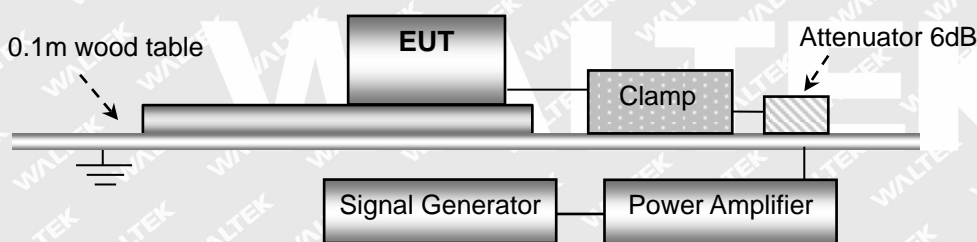

11.3 Test Performance

Performance Criterion:	Mode	Verdict
		TM1-TM4

Note: TM4 for CT,CR

11.4 Environmental Conditions

Temperature:	25 °C
Relative Humidity:	53%
ATM Pressure:	1011 mbar

11.5 Continuous Conducted Disturbances Test Data

Sweep frequency range: 150kHz~80MHz

Frequency step: 1% of fundamental

Dwell time: 1 second

Waltek Testing Group (Shenzhen) Co., Ltd.

[Http://www.waltek.com.cn](http://www.waltek.com.cn)



Test Mode		TM1-TM4		
Level	Voltage (V) (rms, unmodulated)	Modulation:	Pass	Fail
1	1	AM 80%, 1kHz sinewave	/	/
2	3	AM 80%, 1kHz sinewave	A	/
3	10	AM 80%, 1kHz sinewave	/	/
X	Special	/	/	/

Test Result: Pass

WALTEK



12. Voltage Dips and Interruptions

12.1 Test Procedure

Test is conducting under the description of EN 61000-4-11.

12.2 Test Setup Block Diagram

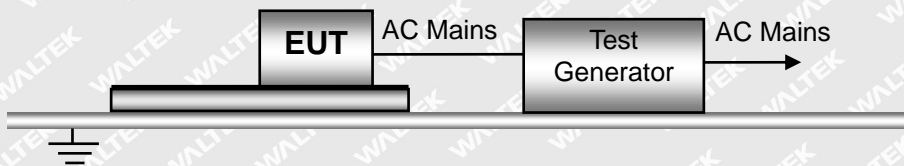

12.3 Test Performance

Performance Criterion:	Mode	Verdict
	TM1-TM4	B for voltage dip/ C for voltage interruption
Note: TM4 for TT,TR		

12.4 Environmental Conditions

Temperature:	25°C
Relative Humidity:	50%
ATM Pressure:	1011 mbar

12.5 Voltage Dips And Interruptions Test Data

U: Voltage dips in % U_T (U_T is rated voltage for the EUT)

T: Test duration

Level	U	T	Phase Angle	N	Pass	Fail
1	100%	10ms	0/90/180/270	3	A	/
2	100%	20ms	0/90/180/270	3	B	/
3	30%	500ms	0/90/180/270	3	B	/
4	100%	5000ms	0/90/180/270	3	C	/

Test Result: Pass



EXHIBIT 1 - EUT PHOTOGRAPHS

Please refer to “ANNEX”.

WALTEK



EXHIBIT 2 - TEST SETUP PHOTOGRAPHS

**Conducted Emission
Test Setup**

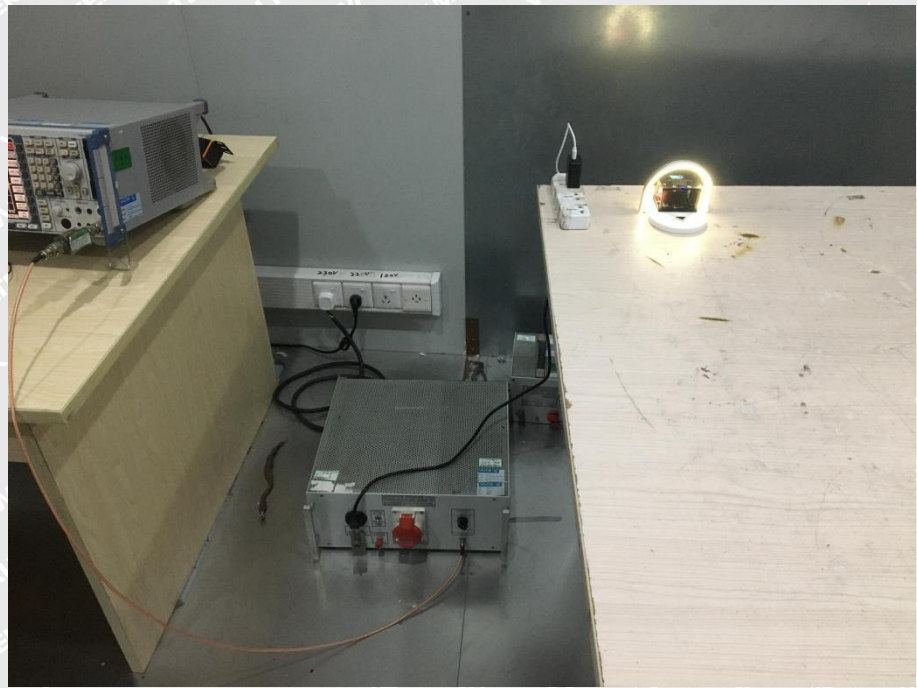

**Radiation Emission Test
View(30MHz to 1GHz)**





Flicker Test View



EN 61000-4-2 Test View

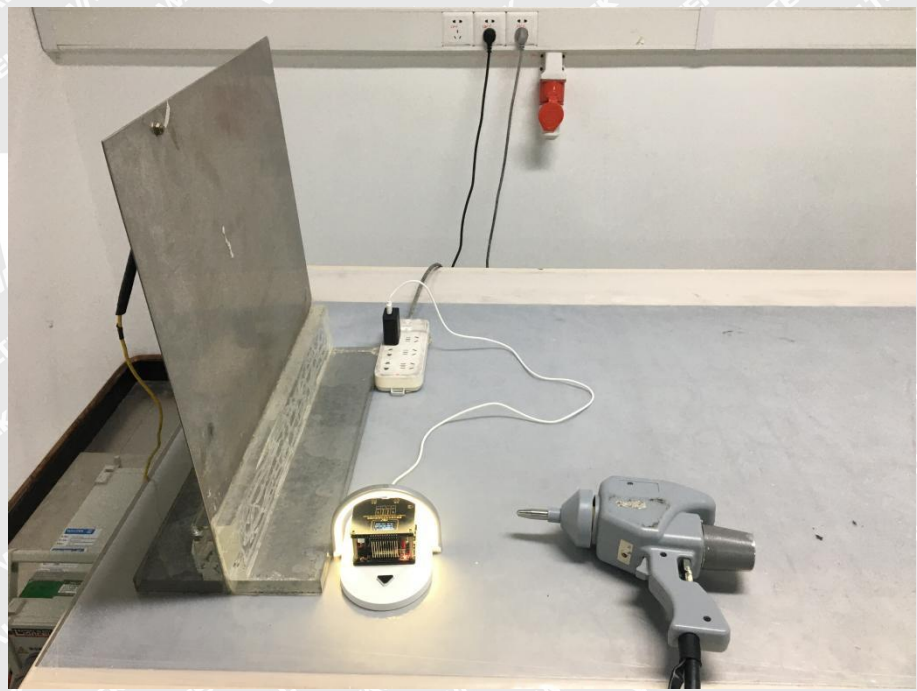



EN 61000-4-3 Test View

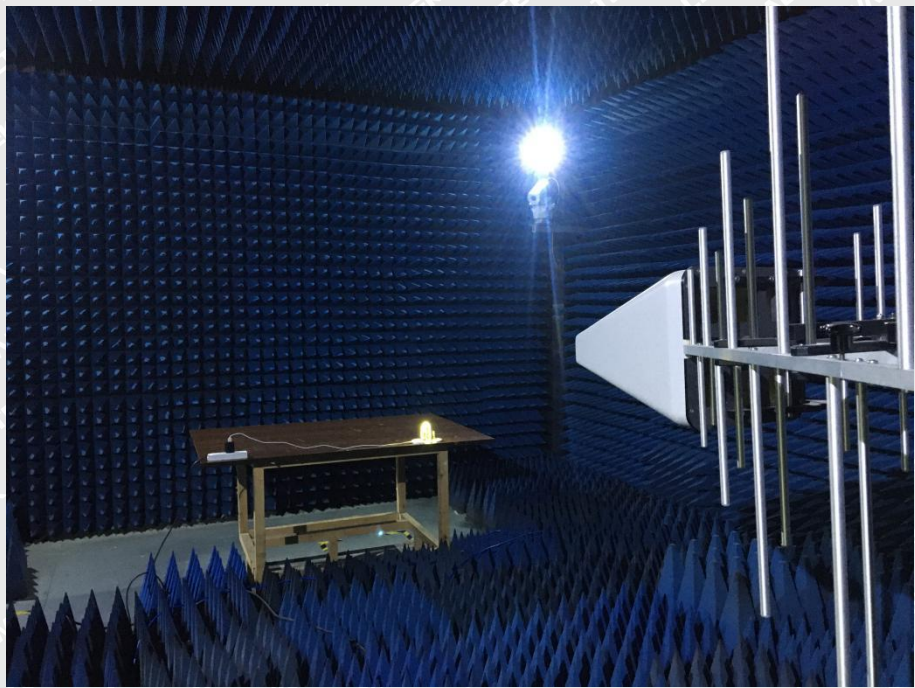

EN 61000-4-4/5/11 Test View

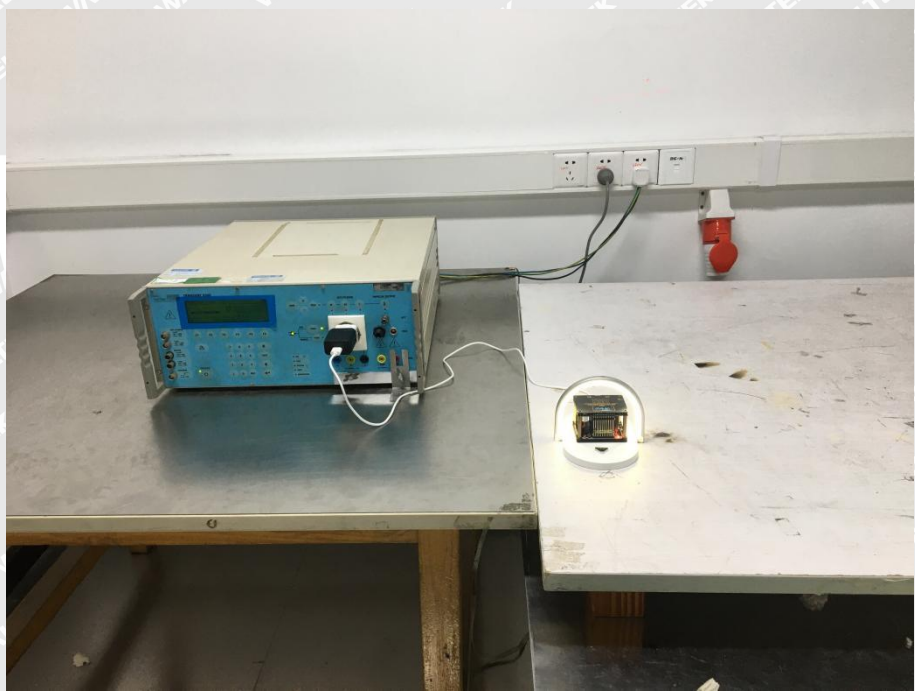



EN 61000-4-6 Test View

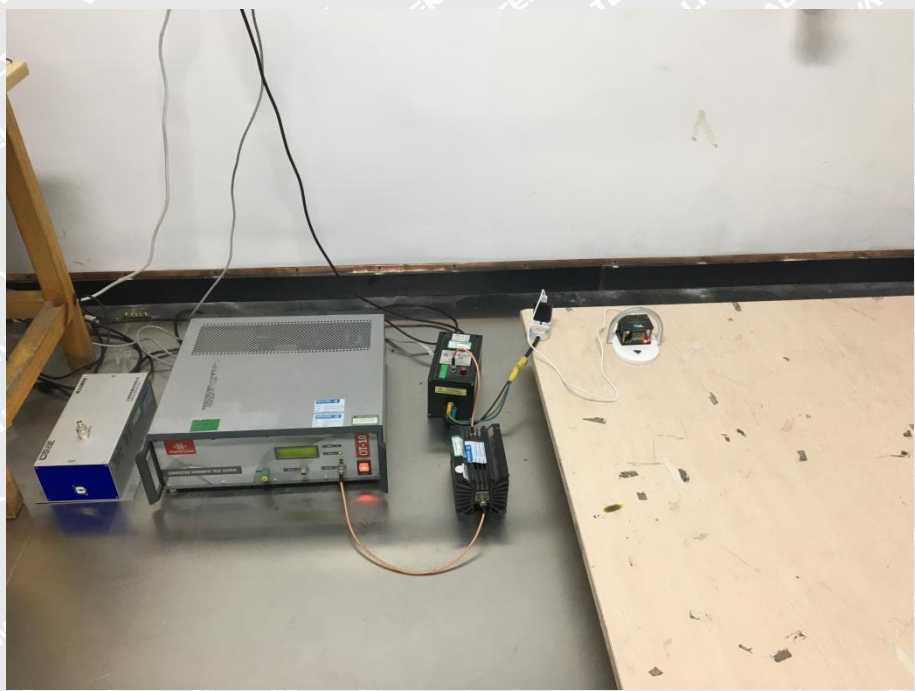

******* END OF REPORT *******

WALTEK



TEST REPORT

Reference No...... : WTF21X10112642W-4
Manufacturer..... : Mid Ocean Brands B.V.
Address..... : 7/F., Kings Tower, 111 King Lam Street, Cheung Sha Wan, Kowloon, Hong Kong
Factory..... : 114538
Product..... : Desk light wireless charger
Test Model..... : MO6514
Standards..... : **EN IEC 55015:2019**
EN 61547:2009
EN IEC 61000-3-2:2019
EN 61000-3-3:2013+A1:2019
Date of Receipt sample.... : Oct. 22, 2021
Date of Test..... : Oct. 22, 2021 to Nov. 25, 2021
Date of Issue..... : Nov. 25, 2021
Test Result..... : **Pass**

Remarks:

The results shown in this test report refer only to the sample(s) tested, this test report cannot be reproduced, except in full, without prior written permission of the company. The report would be invalid without specific stamp of test institute and the signatures of compiler and approver.

Prepared By:

Waltek Testing Group (Shenzhen) Co., Ltd.

Address: 1/F., Room 101, Building 1, Hongwei Industrial Park, Liuxian 2nd Road,
Block 70 Bao'an District, Shenzhen, Guangdong, China

Tel.: +86-755-33663308

Fax.: +86-755-33663309

Tested by:

Reviewed By:

Approved & Authorized By:

Jason Su / Project Engineer

Evan Cai / EMC Manager

Silin Chen / Manager



TABLE OF CONTENTS

1. GENERAL INFORMATION.....	5
1.1 PRODUCT DESCRIPTION FOR EQUIPMENT UNDER TEST (EUT).....	5
1.2 TEST STANDARDS.....	6
1.3 TEST METHODOLOGY.....	6
1.4 EUT SETUP AND OPERATION MODE.....	7
1.5 PERFORMANCE CRITERIA FOR EMS.....	8
1.6 TEST EQUIPMENT LIST AND DETAILS.....	9
2. SUMMARY OF TEST RESULTS.....	10
3. CONDUCTED EMISSION.....	11
3.1 MEASUREMENT UNCERTAINTY.....	11
3.2 BASIC TEST SETUP BLOCK DIAGRAM.....	11
3.3 ENVIRONMENTAL CONDITIONS.....	12
3.4 SUMMARY OF TEST RESULTS.....	12
4. RADIATED ELECTROMAGNETIC DISTURBANCES (9KHZ TO 30MHZ).....	15
4.1 MEASUREMENT UNCERTAINTY.....	15
4.2 BASIC TEST SETUP BLOCK DIAGRAM.....	15
4.3 ENVIRONMENTAL CONDITIONS.....	15
4.4 SUMMARY OF TEST RESULTS.....	15
5. RADIATED ELECTROMAGNETIC DISTURBANCES (30MHZ TO 1000MHZ).....	19
5.1 MEASUREMENT UNCERTAINTY.....	19
5.2 BASIC TEST SETUP BLOCK DIAGRAM.....	19
5.3 CORRECTED AMPLITUDE & MARGIN CALCULATION.....	20
5.4 ENVIRONMENTAL CONDITIONS.....	20
5.5 SUMMARY OF TEST RESULTS.....	20
6. HARMONIC CURRENT EMISSIONS.....	23
6.1 TEST PROCEDURE.....	23
6.2 TEST STANDARDS.....	23
6.3 ENVIRONMENTAL CONDITIONS.....	23
6.4 BASIC TEST SETUP BLOCK DIAGRAM.....	23
6.5 HARMONIC CURRENT EMISSIONS TEST DATA.....	23
7. VOLTAGE FLUCTUATION FLICKER.....	24
7.1 TEST PROCEDURE.....	24
7.2 TEST STANDARDS.....	24
7.3 ENVIRONMENTAL CONDITIONS.....	24
7.4 BASIC TEST SETUP BLOCK DIAGRAM.....	24
7.5 VOLTAGE FLUCTUATION AND FLICKER TEST DATA.....	24
8. ELECTROSTATIC DISCHARGES (ESD).....	26
8.1 TEST PROCEDURE.....	26
8.2 TEST PERFORMANCE.....	26
8.3 ENVIRONMENTAL CONDITIONS.....	26
8.4 BASIC TEST SETUP BLOCK DIAGRAM.....	26
8.5 ELECTROSTATIC DISCHARGE IMMUNITY TEST DATA.....	27
9. CONTINUOUS RF ELECTROMAGNETIC FIELD DISTURBANCES (RS).....	28
9.1 TEST PROCEDURE.....	28
9.2 TEST PERFORMANCE.....	28
9.3 ENVIRONMENTAL CONDITIONS.....	28
9.4 BASIC TEST SETUP BLOCK DIAGRAM.....	28
9.5 CONTINUOUS RADIATED DISTURBANCES TEST DATA.....	29
10. ELECTRICAL FAST TRANSIENTS (EFT).....	30
10.1 TEST PROCEDURE.....	30
10.2 TEST PERFORMANCE.....	30



10.3 ENVIRONMENTAL CONDITIONS.....	30
10.4 BASIC TEST SETUP BLOCK DIAGRAM.....	30
10.5 ELECTRICAL FAST TRANSIENTS TEST DATA.....	31
11. SURGES.....	32
11.1 TEST PROCEDURE.....	32
11.2 TEST PERFORMANCE.....	32
11.3 ENVIRONMENTAL CONDITIONS.....	32
11.4 BASIC TEST SETUP BLOCK DIAGRAM.....	32
11.5 SURGE TEST DATA.....	33
12. CONTINUOUS INDUCED RF DISTURBANCES (C/S).....	34
12.1 TEST PROCEDURE.....	34
12.2 TEST PERFORMANCE.....	34
12.3 ENVIRONMENTAL CONDITIONS.....	34
12.4 BASIC TEST SETUP BLOCK DIAGRAM.....	34
12.5 CONTINUOUS CONDUCTED DISTURBANCES TEST DATA.....	35
13. POWER-FREQUENCY MAGNETIC FIELDS (PFMF).....	36
13.1 TEST PROCEDURE.....	36
13.2 TEST PERFORMANCE.....	36
13.3 ENVIRONMENTAL CONDITIONS.....	36
13.4 BASIC TEST SETUP BLOCK DIAGRAM.....	36
13.5 POWER-FREQUENCY MAGNETIC FIELD TEST DATA.....	37
14. VOLTAGE DIPS AND INTERRUPTIONS.....	38
14.1 TEST PROCEDURE.....	38
14.2 TEST PERFORMANCE.....	38
14.3 ENVIRONMENTAL CONDITIONS.....	38
14.4 BASIC TEST SETUP BLOCK DIAGRAM.....	38
14.5 VOLTAGE DIPS AND INTERRUPTIONS TEST DATA.....	39
EXHIBIT 1 - EUT PHOTOGRAPHS.....	40
EXHIBIT 2 - TEST SETUP PHOTOGRAPHS.....	41



Report version

Version No.	Date of issue	Description
Rev.00	Nov. 25, 2021	Original
/	/	/

WALTEK



1. GENERAL INFORMATION

1.1 Product Description for Equipment Under Test (EUT)

Client Information

Manufacturer: Mid Ocean Brands B.V.
Address of manufacturer: 7/F., Kings Tower, 111 King Lam Street, Cheung
Sha Wan, Kowloon, Hong Kong
Factory: 114538

General Description of EUT	
Product Name:	Desk light wireless charger
Trade Name:	/
Model No.:	MO6514
Adding Model(s):	/
<i>Note: The test data is gathered from a production sample, provided by the manufacturer.</i>	

Technical Characteristics of EUT	
Rated Voltage:	Wireless output:5W/7.5W/10W/15W
Rated Current:	/
Rated Power:	/
Power Adaptor Model:	/
Highest Internal Frequency:	Above 108MHz



1.2 Test Standards

The tests were performed according to following standards:

EN IEC 55015:2019: Limits and methods of measurement of radio disturbance characteristics of electrical lighting and similar equipment.

EN 61547:2009: Electromagnetic for general lighting purposes - EMC immunity requirements.

EN IEC 61000-3-2:2019: Electromagnetic compatibility (EMC) -- Part 3-2: Limits - Limits for harmonic current emissions (equipment input current up to and including 16 A per phase).

EN 61000-3-3:2013+A1:2019: Electromagnetic compatibility (EMC) -- Part 3-3: Limits - Limitation of voltage changes, voltage fluctuations and flicker in public low-voltage supply systems, for equipment with rated current ≤ 16 A per phase and not subject to conditional connection.

Maintenance of compliance is the responsibility of the manufacturer. Any modification of the product maybe which result in lowering the emission/immunity should be checked to ensure compliance has been maintained.

1.3 Test Methodology

All measurements contained in this report were conducted with the standards EN IEC 55015 , EN IEC 61000-3-2, EN 61000-3-3 and EN 61547 for general lighting purposes equipment, and all related testing and measurement techniques intentional standards.



1.4 EUT Setup and Operation Mode

The equipment under test (EUT) was configured to measure its highest possible emission/immunity level. The test modes were adapted according to the operation manual for use, more detailed description as follows:

Test Mode List			
Test Mode	Description	Remark	Power Supply Mode
TM1	Light on	Connect to the Adapter; AC230V 50Hz for adapter, and Light on	/

EUT Cable List and Details				
Cable Description	Length (m)	Shielded/Unshielded	With / Without Ferrite	With / Without Chip
USB Cable	1.0	Unshielded	Without Ferrite	/

Special Cable List and Details				
Cable Description	Length (m)	Shielded/Unshielded	With / Without Ferrite	With / Without Chip
/	/	/	/	/

Auxiliary Equipment List and Details			
Description	Manufacturer	Model	Serial Number
Adapter	/	QC01	/



1.5 Performance Criteria for EMS

All the test data has been collected, reduced, and analyzed within this report in accordance with Immunity requires the following as specific performance criteria:

- A. The apparatus shall continue to operate as intended during and after the test. The manufacturer specifies some minimum performance level. The performance level may be specified by the manufacturer as a permissible loss of performance.
- B. The apparatus shall continue to operate as intended after the test. This indicates that the EUT does not need to function at normal performance levels during the test, but must recover. Again some minimal performance is defined by the manufacturer. No change in operating state or loss of data is permitted.
- C. Temporary loss of function is allowed. Operation of the EUT may stop as long as it is either automatically reset or can be manually restored by operation of the controls.

WALTEK



1.6 Test Equipment List and Details

Description	Manufacturer	Model	Serial No.	Cal. Date	Due. Date
Spectrum Analyzer	Rohde & Schwarz	FSP	836079/035	2021-03-30	2022-03-29
EMI Test Receiver	Rohde & Schwarz	ESVB	825471/005	2021-04-12	2022-04-11
Amplifier	Agilent	8447F	3113A06717	2021-04-12	2022-04-11
Amplifier	C&D	PAP-1G18	2002	2021-04-12	2022-04-11
Trilog Broadband Antenna	Schwarz beck	VULB9163	9163-333	2021-03-20	2023-03-19
Horn Antenna	ETS	3117	00086197	2021-03-19	2023-03-18
Loop Antenna	Schwarz beck	FMZB 1516	9773	2021-03-20	2023-03-19
Trilog Broadband Antenna	Schwarz beck	VULB9163(B)	9163-635	2021-04-09	2023-04-08
Amplifier	Agilent	8447D	2944A10179	2021-04-12	2022-04-11
EMI Test Receiver	Rohde & Schwarz	ESPI	101611	2021-04-12	2022-04-11
Pulse Limiter	Rohde & Schwarz	ESH3-Z2	100911	2021-04-15	2022-04-14
AC LISN	Schwarz beck	NSLK8126	8126-224	2021-04-12	2022-04-11
8-WIRE LISN	Schwarz beck	8158	CAT3-8158-0059	2021-04-12	2022-04-11
8-WIRE LISN	Schwarz beck	8158	CAT5-8158-0117	2021-04-12	2022-04-11
Loop Antenna	ZHINAN	ZN30401	19037	2021-04-26	2023-04-25
PMF Generator	LIONCEL	PMF-801C-C	0171101	2021-04-12	2022-04-11
PMF Antenna	LIONCEL	PMF-801C-A	0180302	2021-04-12	2022-04-11
Instantaneous PMF Generator Module	LIONCEL	PMF-801C-T	0171001	2021-04-12	2022-04-11
Digital Power Analyzer	California Instrument	CTS	72831	2021-04-12	2022-04-11
Power Source	California Instrument	5001IX-CTS-400	25965	2021-04-12	2022-04-11
ESD Generator	LIONCEL	ESD-203B	0170901	2021-04-16	2022-04-15
Transient 2000	EMC PARTNER	TRA2000	863	2021-04-12	2022-04-11
Couple Clamp	EMC PARTNER	CN-EFT1000	513	2021-04-12	2022-04-11
CONDUCTED IMMUNITY TEST SYSTEM	FRANKONIA	CIT-10/75	126B1247/2013	2021-01-08	2022-01-07
Attenuator	EMTEST	MA-5100/6BF2	1009	2021-03-30	2022-03-29
CDN	Luthi	L-801M2/M3	2665	2021-04-12	2022-04-11
Signal Generator	HP	8688B	3438A00604	2021-03-30	2022-03-29
Power Meter	KEITHLEY	3500	1162591	2021-03-27	2022-03-26
Power Meter	KEITHLEY	3500	1121428	2021-03-27	2022-03-26
RF Power Amplifier	MicoTop	MPA-80-1000-250	MPA1906239	2021-03-27	2022-03-26
RF Power Amplifier	MicoTop	MPA-80-1000-100	MPA1906238	2021-03-27	2022-03-26
Antenna	SCHWARZBECK	STLP 9129	9129 114	N/A	N/A



2. SUMMARY OF TEST RESULTS

Standards	Description of Test Item	Result
EN IEC55015	Disturbance Voltages	Compliant
	Radiated Electromagnetic Disturbances (Frequency range 9kHz to 30MHz)	Compliant
	Radiated Electromagnetic Disturbances (Frequency range 30MHz to 1000MHz)	Compliant
EN IEC 61000-3-2	Harmonic Current Emission	N/A
EN 61000-3-3	Voltage Fluctuation And Flicker	Compliant
EN 61547	Electrostatic Discharge Immunity in accordance with EN 61000-4-2	Compliant
	Radio-Frequency Electromagnetic Field Immunity in accordance with EN 61000-4-3	Compliant
	Electrical Fast Transient/Burst Immunity in accordance with EN 61000-4-4	Compliant
	Surges Immunity in accordance with EN 61000-4-5	Compliant
	Injected Currents Immunity in accordance with EN 61000-4-6	Compliant
	Power-frequency Magnetic Field Immunity in accordance with EN 61000-4-8	Compliant
	Voltage Dips/Interruptions Immunity in accordance with EN 61000-4-11	Compliant

N/A: not applicable



3. Conducted Emission

3.1 Measurement Uncertainty

Base on NIS 81, The Treatment of Uncertainty in EMC Measurements, the best estimate of the uncertainty of any conducted emissions measurement:

Measurement uncertainty		
Parameter	Conditions	Uncertainty
Conducted Emissions	Conducted	9-150kHz $\pm 3.74\text{dB}$
		0.15-30MHz $\pm 3.34\text{dB}$

3.2 Basic Test Setup Block Diagram

AC port

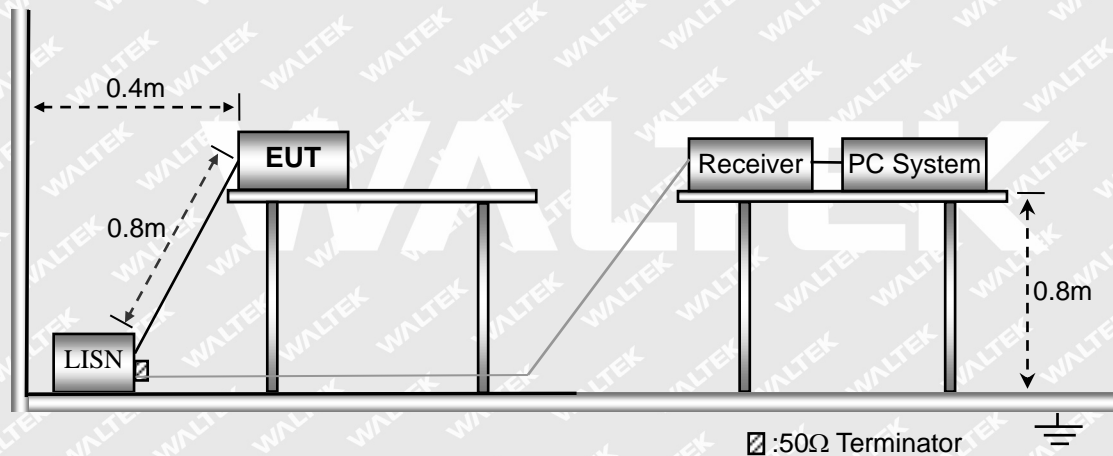



3.3 Environmental Conditions

Temperature:	23.5 °C
Relative Humidity:	54 %
ATM Pressure:	1015 mbar

3.4 Summary of Test Results

Please find the results below:

WALTEK



Test mode:	TM1	Polarity:	Line
------------	-----	-----------	------

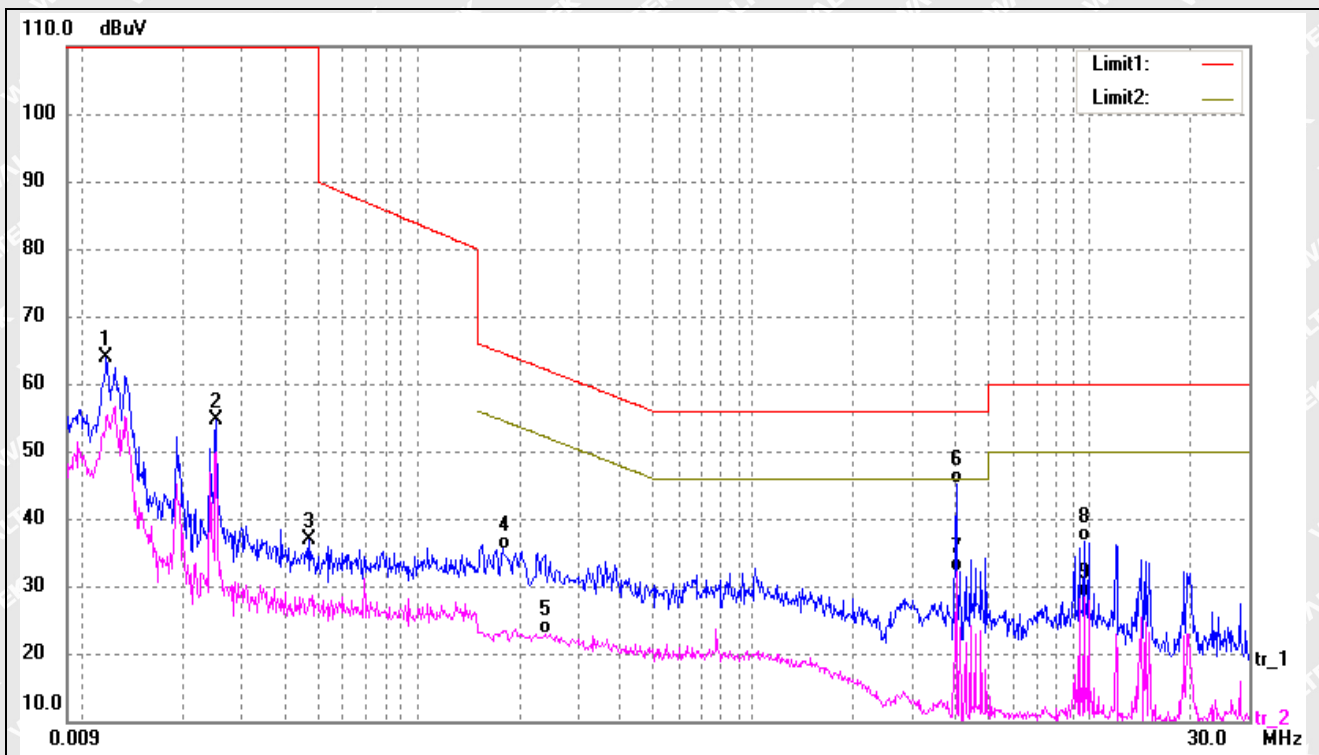

No.	Frequency (MHz)	Reading (dBuV)	Correct (dB)	Result (dBuV)	Limit (dBuV)	Margin (dB)	Detector
1	0.0119	53.58	10.25	63.83	110.00	-46.17	peak
2	0.0251	44.26	10.26	54.52	110.00	-55.48	peak
3	0.0476	26.60	10.30	36.90	110.00	-73.10	peak
4	0.1780	25.13	10.37	35.50	64.58	-29.08	QP
5	0.2380	12.54	10.36	22.90	52.17	-29.27	AVG
6*	4.0220	35.01	10.04	45.05	56.00	-10.95	QP
7	4.0220	22.02	10.04	32.06	46.00	-13.94	AVG
8	9.6780	26.63	9.88	36.51	60.00	-23.49	QP
9	9.6780	18.53	9.88	28.41	50.00	-21.59	AVG



Test mode:	TM1	Polarity:	Neutral
------------	-----	-----------	---------

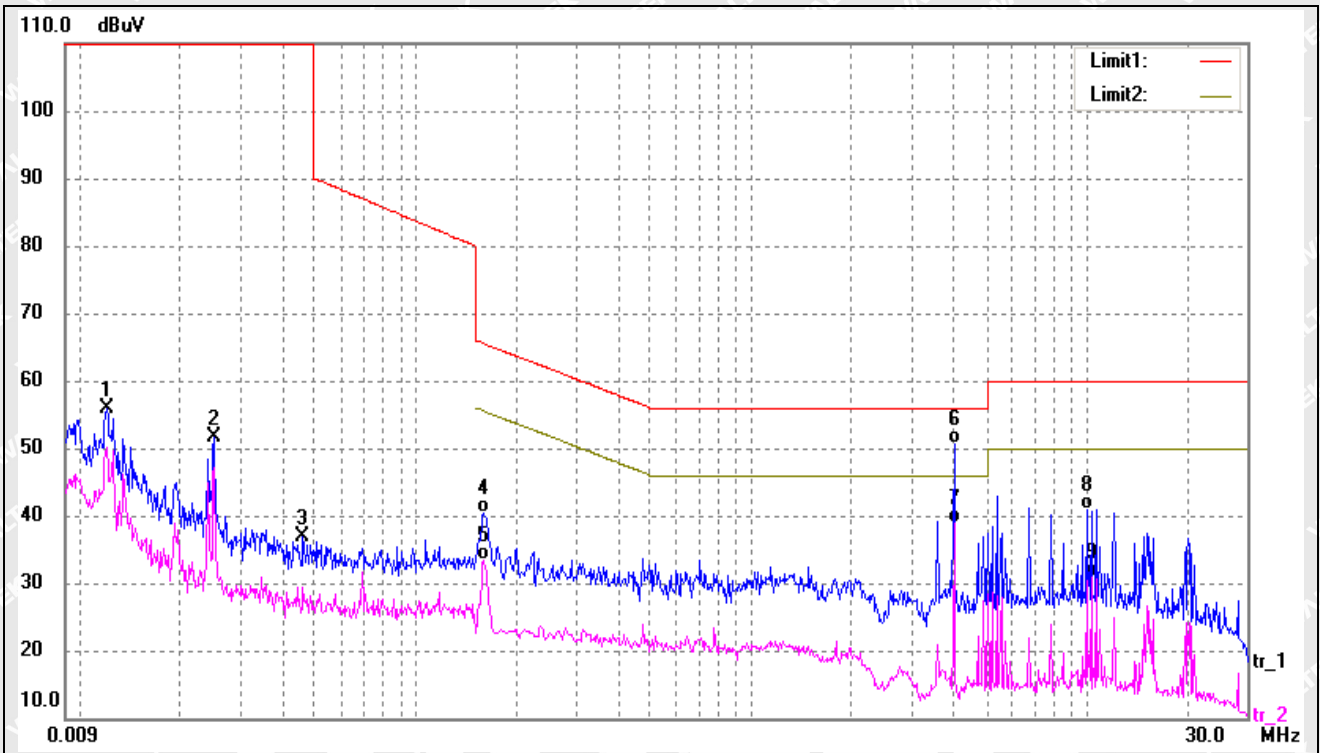

No.	Frequency (MHz)	Reading (dBuV)	Correct (dB)	Result (dBuV)	Limit (dBuV)	Margin (dB)	Detector
1	0.0120	45.62	10.25	55.87	110.00	-54.13	peak
2	0.0251	41.29	10.26	51.55	110.00	-58.45	peak
3	0.0463	26.60	10.30	36.90	110.00	-73.10	peak
4	0.1580	30.09	10.37	40.46	65.57	-25.11	QP
5	0.1580	23.04	10.37	33.41	55.57	-22.16	AVG
6*	4.0220	40.63	10.04	50.67	56.00	-5.33	QP
7	4.0220	28.91	10.04	38.95	46.00	-7.05	AVG
8	9.9900	30.99	9.87	40.86	60.00	-19.14	QP
9	10.3140	20.95	9.89	30.84	50.00	-19.16	AVG



4. Radiated Electromagnetic Disturbances (9kHz to 30MHz)

4.1 Measurement Uncertainty

Base on NIS 81, The Treatment of Uncertainty in EMC Measurements, the best estimate of the uncertainty of any radiation emissions measurement is ± 3.6 dB.

4.2 Basic Test Setup Block Diagram

The Radiation Electromagnetic Disturbance (9kHz to 30MHz) test was performed in accordance with the EN IEC 55015

2m Loop Antenna

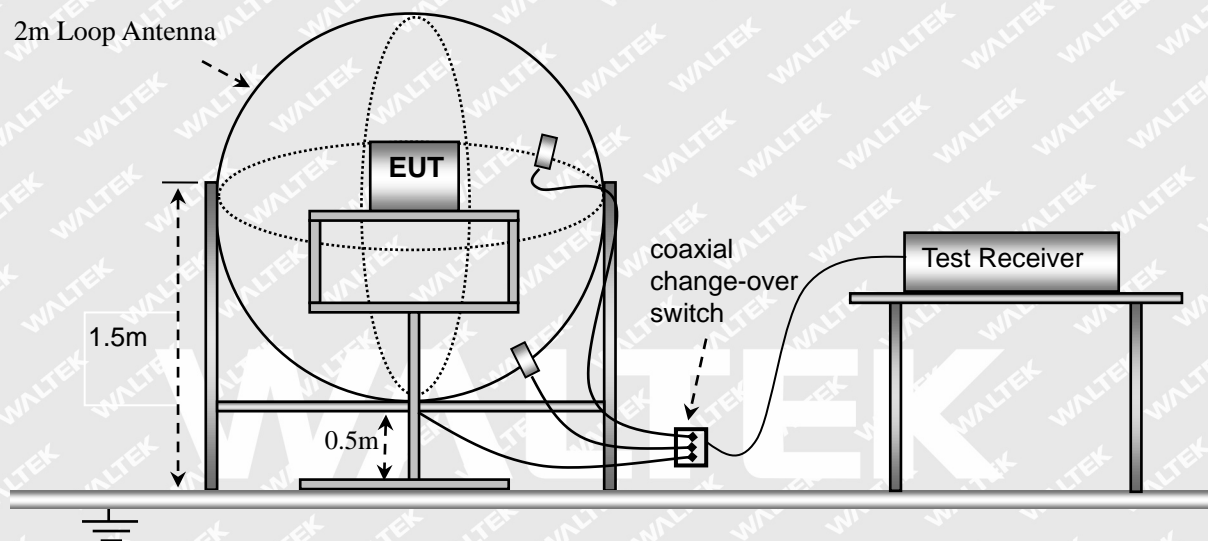

4.3 Environmental Conditions

Temperature:	22.5 °C
Relative Humidity:	54 %
ATM Pressure:	1015 mbar

4.4 Summary of Test Results

Please find the results below:



Test mode:	TM1	Polarity:	X
------------	-----	-----------	---

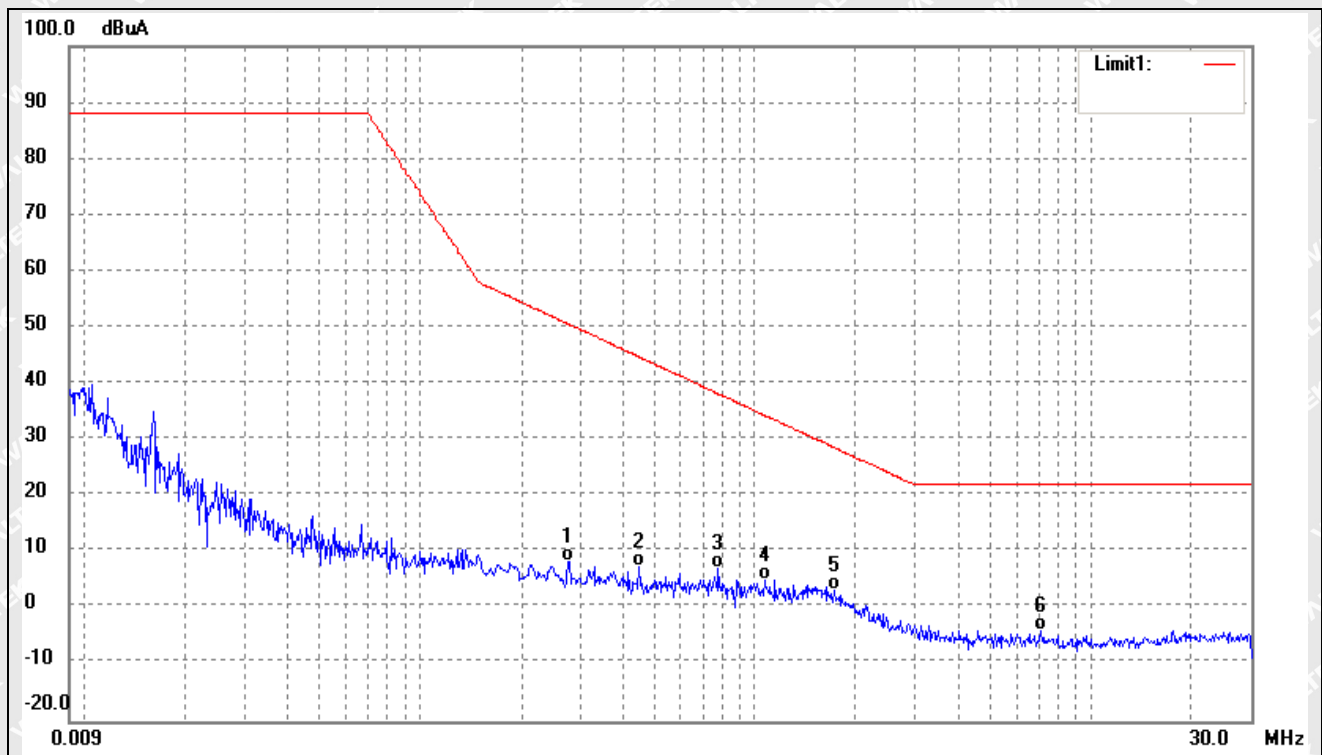

No.	Frequency (MHz)	Reading (dBuA)	Correct (dB/m)	Result (dBuA)	Limit (dBuA)	Margin (dB)	Detector
1	0.2779	-12.09	20.54	8.45	50.58	-42.13	QP
2	0.4500	-12.88	20.31	7.43	44.79	-37.36	QP
3	0.7740	-13.04	20.07	7.03	38.28	-31.25	QP
4	1.0620	-14.97	20.09	5.12	34.48	-29.36	QP
5*	1.7220	-17.15	20.42	3.27	28.67	-25.40	QP
6	7.1300	-24.42	20.53	-3.89	22.00	-25.89	QP



Test mode:	TM1	Polarity:	Y
------------	-----	-----------	---

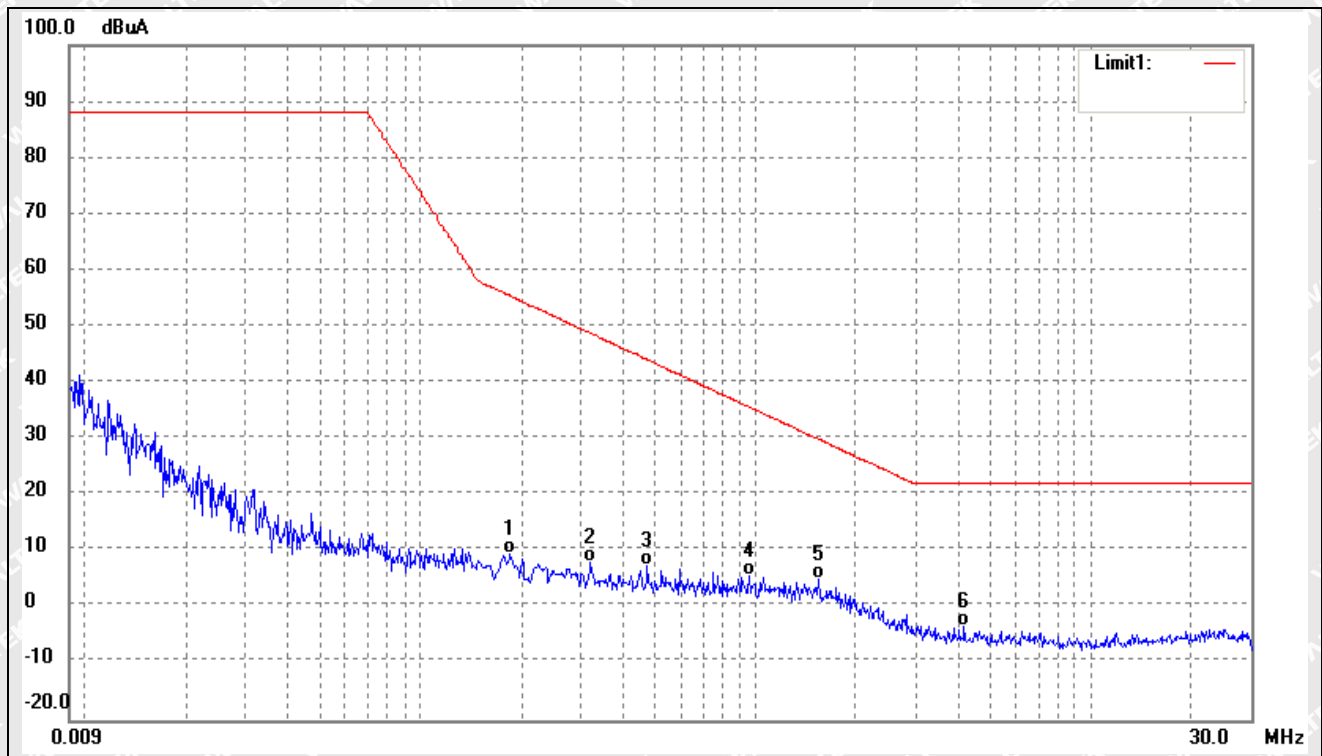

No.	Frequency (MHz)	Reading (dBuA)	Correct (dB/m)	Result (dBuA)	Limit (dBuA)	Margin (dB)	Detector
1	0.1860	-11.35	20.79	9.44	55.41	-45.97	QP
2	0.3220	-12.28	20.48	8.20	48.82	-40.62	QP
3	0.4780	-12.86	20.28	7.42	44.07	-36.65	QP
4	0.9620	-14.33	20.06	5.73	35.67	-29.94	QP
5*	1.5460	-15.26	20.33	5.07	29.97	-24.90	QP
6	4.1860	-24.09	20.67	-3.42	22.00	-25.42	QP



Test mode:	TM1	Polarity:	Z
------------	-----	-----------	---

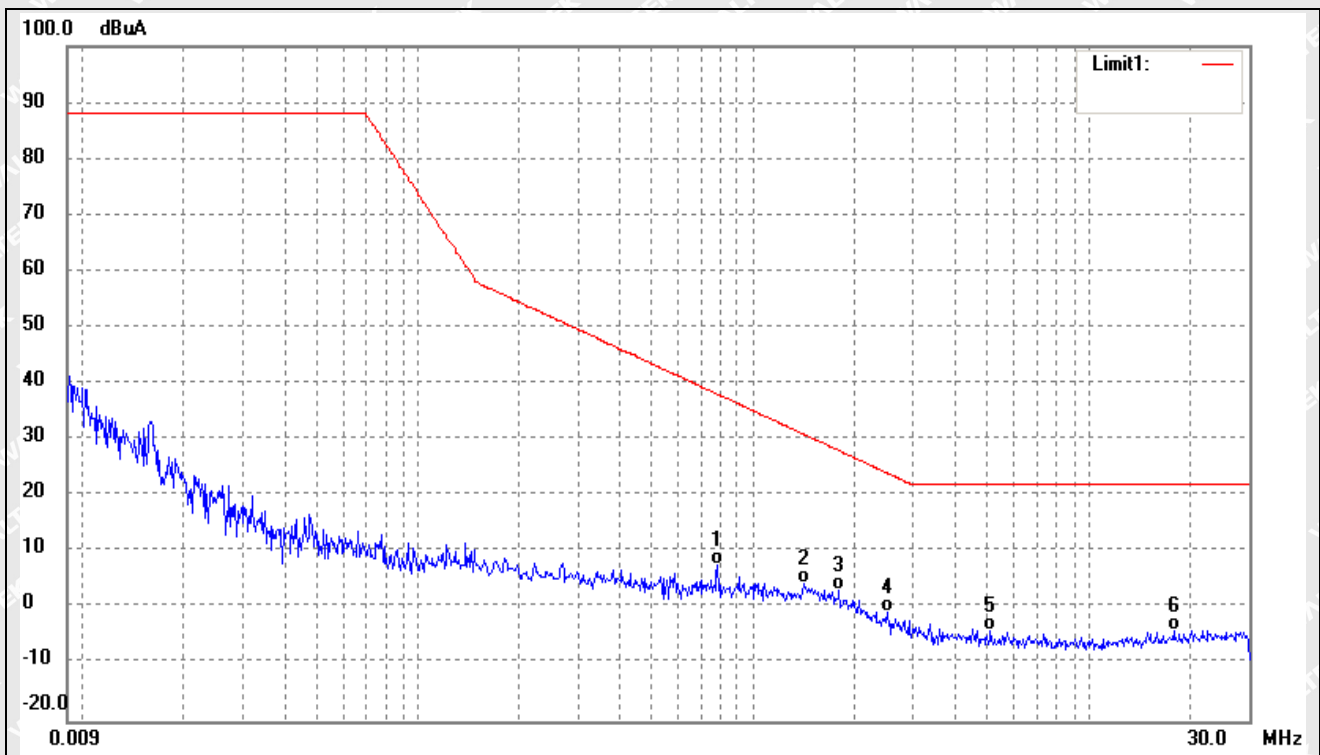

No.	Frequency (MHz)	Reading (dBuA)	Correct (dB/m)	Result (dBuA)	Limit (dBuA)	Margin (dB)	Detector
1	0.7820	-12.40	20.07	7.67	38.16	-30.49	QP
2	1.4140	-15.96	20.27	4.31	31.04	-26.73	QP
3	1.7980	-17.25	20.46	3.21	28.15	-24.94	QP
4*	2.5100	-21.28	20.59	-0.69	24.14	-24.83	QP
5	5.0780	-24.54	20.71	-3.83	22.00	-25.83	QP
6	17.9940	-25.15	21.06	-4.09	22.00	-26.09	QP



5. Radiated Electromagnetic Disturbances (30MHz to 1000MHz)

5.1 Measurement Uncertainty

Base on NIS 81, The Treatment of Uncertainty in EMC Measurements, the best estimate of the uncertainty of any radiation emissions measurement:

Measurement uncertainty		
Parameter	Conditions	Uncertainty
Radiated Emissions	Radiated	30-200MHz $\pm 4.52\text{dB}$
		0.2-1GHz $\pm 5.56\text{dB}$
		1-6GHz $\pm 3.84\text{dB}$
		6-18GHz $\pm 3.92\text{dB}$

5.2 Basic Test Setup Block Diagram

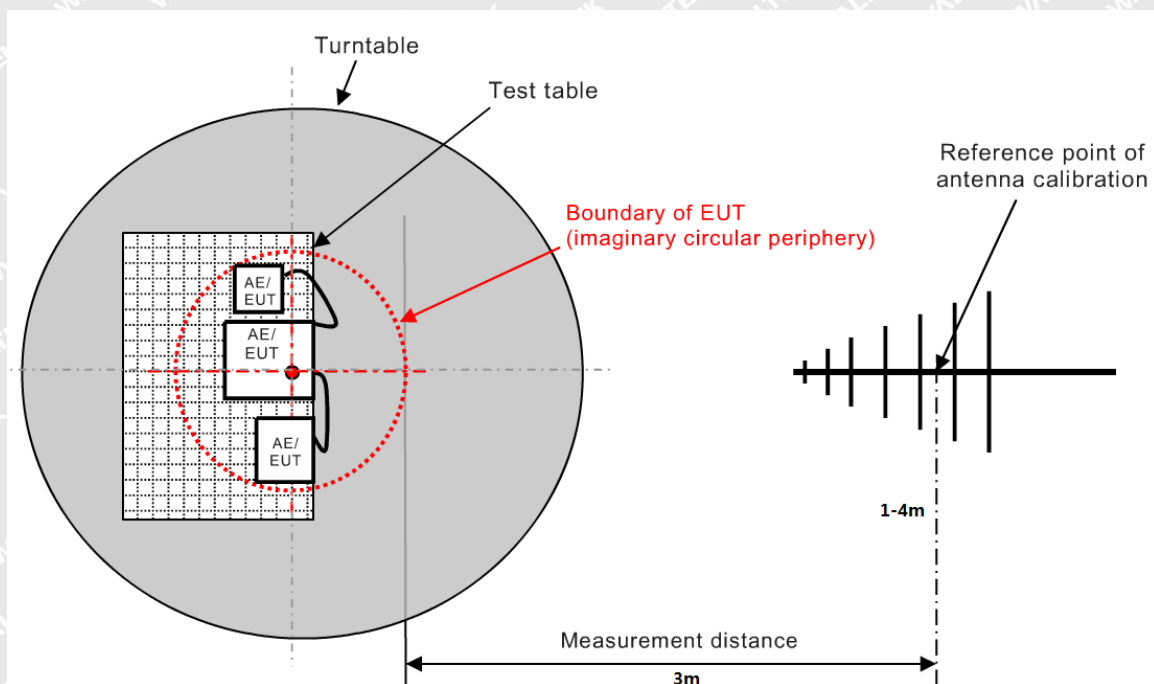



5.3 Corrected Amplitude & Margin Calculation

The Corrected Amplitude is calculated by adding the Antenna Factor and the Cable Factor, and subtracting the Amplifier Gain from the Amplitude reading. The basic equation is as follows:

$$\text{Corr. Ampl.} = \text{Indicated Reading} + \text{Correct Correct} = \text{Ant.Factor} + \text{Cable Loss} - \text{Ampl.Gain}$$

The “**Margin**” column of the following data tables indicates the degree of compliance with the applicable limit. For example, a margin of -6dB μ V means the emission is 6dB μ V below the maximum limit for a lighting device. The equation for margin calculation is as follows:

$$\text{Margin} = \text{Corr. Ampl.} - \text{EN IEC 55015 Limit}$$

5.4 Environmental Conditions

Temperature:	23.5° C
Relative Humidity:	54 %
ATM Pressure:	1011 mbar

5.5 Summary of Test Results

Please find the results below:



Test mode:	TM1	Polarity:	Horizontal
------------	-----	-----------	------------

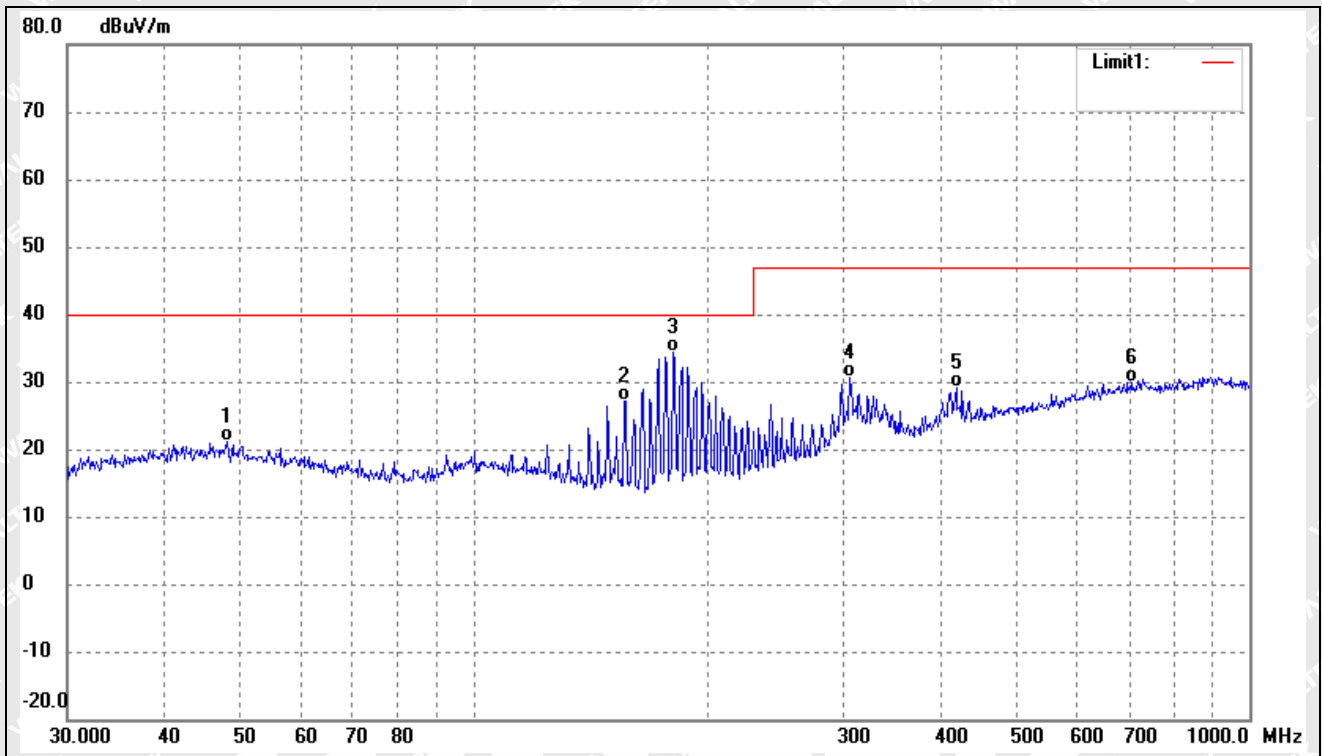

No.	Frequency (MHz)	Reading (dBuV/m)	Correct (dB/m)	Result (dBuV/m)	Limit (dBuV/m)	Margin (dB)	Degree ()	Height (cm)	Remark
1	48.1626	28.14	-6.97	21.17	40.00	-18.83	-	-	QP
2	156.4578	39.50	-12.32	27.18	40.00	-12.82	-	-	QP
3	181.2834	45.49	-11.12	34.37	40.00	-5.63	-	-	QP
4	305.6800	37.49	-6.79	30.70	47.00	-16.30	-	-	QP
5	419.1081	32.46	-3.38	29.08	47.00	-17.92	-	-	QP
6	704.2261	28.48	1.46	29.94	47.00	-17.06	-	-	QP



Test mode:	TM1	Polarity:	Vertical
------------	-----	-----------	----------

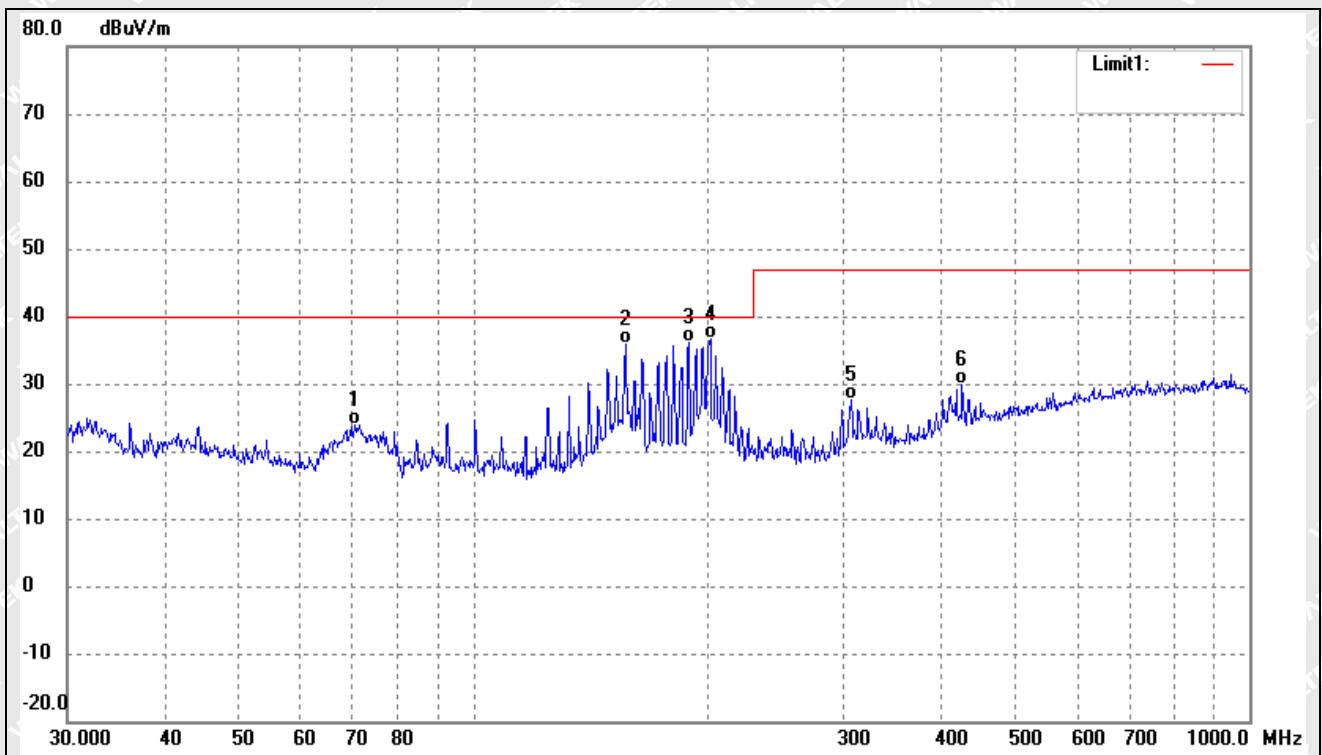

No.	Frequency (MHz)	Reading (dBuV/m)	Correct (dB/m)	Result (dBuV/m)	Limit (dBuV/m)	Margin (dB)	Degree ()	Height (cm)	Remark
1	70.3365	34.02	-10.20	23.82	40.00	-16.18	-	-	QP
2	157.0074	48.25	-12.29	35.96	40.00	-4.04	-	-	QP
3	189.7385	46.29	-10.07	36.22	40.00	-3.78	-	-	QP
4	202.1005	46.31	-9.65	36.66	40.00	-3.34	-	-	QP
5	306.7537	34.41	-6.74	27.67	47.00	-19.33	-	-	QP
6	426.5210	33.12	-3.18	29.94	47.00	-17.06	-	-	QP

Remark: '-' Means the test Degree and Height are not recorded by the test software and only show the worst case in the test report.



6. Harmonic Current Emissions

6.1 Test Procedure

Test is conducted under the description of EN IEC 61000-3-2.

6.2 Test Standards

EN IEC 61000-3-2, Clause 7.3 Limits for Class C equipment.

6.3 Environmental Conditions

Temperature:	22.5°C
Relative Humidity:	54 %
ATM Pressure:	1022 mbar

6.4 Basic Test Setup Block Diagram

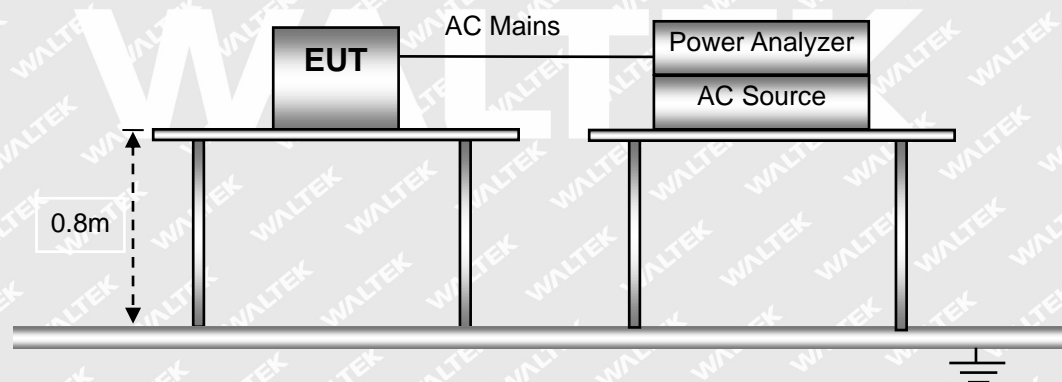

6.5 Harmonic Current Emissions Test Data

According to Clause 7.3b of EN IEC 61000-3-2, the rated power of the EUT(LED equipment) is less than 5W, belong to 'equipment with a rated power of 5W or less', therefore 'limits are not specified in this edition of the standards'. It is deem to full fit the requirements of the standards.

Result: The EUT is compliance with the requirements of this section.



7. Voltage Fluctuation Flicker

7.1 Test Procedure

Test is conducted under the description of EN 61000-3-3.

7.2 Test Standards

EN 61000-3-3, Limit: Clause 5.

7.3 Environmental Conditions

Temperature:	22.5 °C
Relative Humidity:	54 %
ATM Pressure:	1022 mbar

7.4 Basic Test Setup Block Diagram

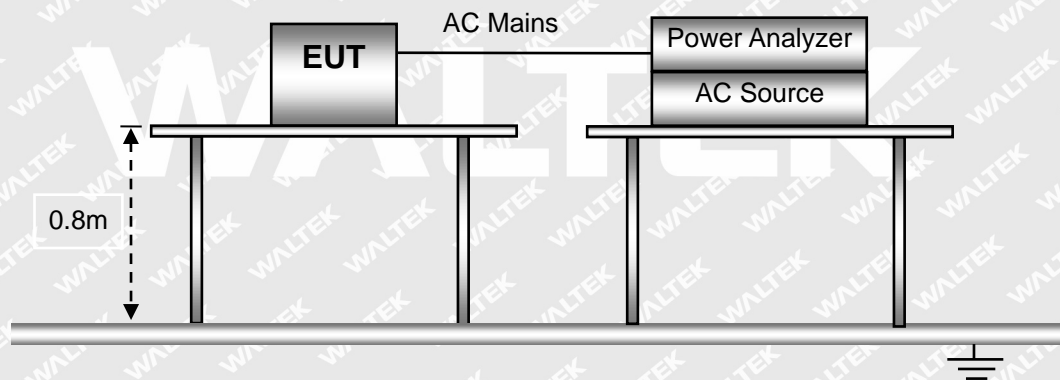

7.5 Voltage Fluctuation and Flicker Test Data



Test mode:	TM1
------------	-----

Test Result: Pass

Status: Test Completed

Pst and limit line

European Limits



Pit and limit line

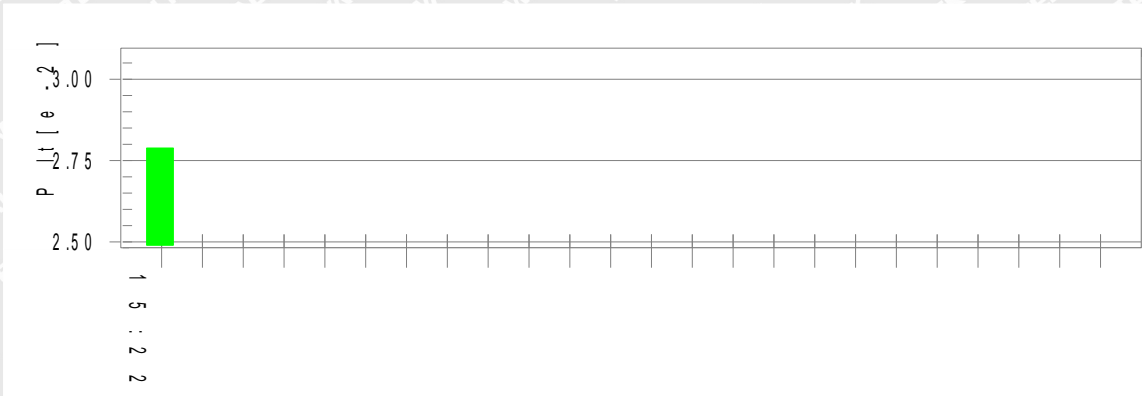

Parameter values recorded during the test:

Vrms at the end of test (Volt): 229.92

T-max (mS):	0	Test limit (mS):	500.0	Pass
Highest dc (%):	0.00	Test limit (%):	3.30	Pass
Highest dmax (%):	0.00	Test limit (%):	4.00	Pass
Highest Pst (10 min. period):	0.064	Test limit:	1.000	Pass



8. Electrostatic Discharges (ESD)

8.1 Test Procedure

Test is conducted under the description of EN 61000-4-2.

8.2 Test Performance

Performance Criterion: B

8.3 Environmental Conditions

Temperature:	22.5 °C
Relative Humidity:	54 %
ATM Pressure:	1011 mbar

8.4 Basic Test Setup Block Diagram

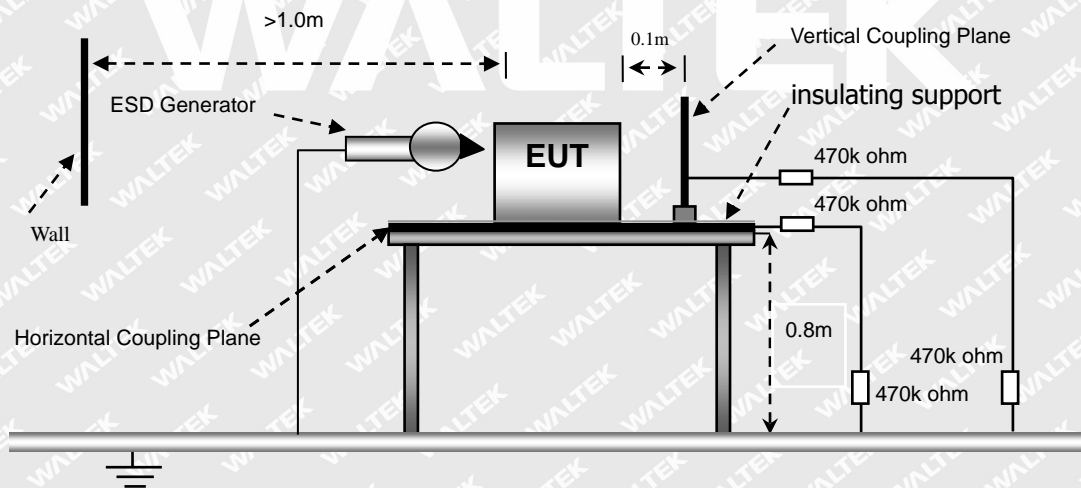



8.5 Electrostatic Discharge Immunity Test Data

Test Mode: TM1

Table 1: Electrostatic Discharge Immunity (Air Discharge)

EN 61000-4-2 Test Points	Test Voltage (kV)									
	-2	+2	-4	+4	-6	+6	-8	+8	-15	+15
USB Port	A	A	A	A	A	A	B	B	/	/
Enclosure	A	A	A	A	A	A	B	B	/	/

Table 2: Electrostatic Discharge Immunity (Direct Contact)

EN 61000-4-2 Test Points	Test Voltage (kV)									
	-2	+2	-4	+4	-6	+6	-8	+8	-15	+15
/	/	/	/	/	/	/	/	/	/	/

Table 3: Electrostatic Discharge Immunity (Indirect Contact HCP & VCP)

EN 61000-4-2 Test Points	Test Voltage (kV)									
	-2	+2	-4	+4	-6	+6	-8	+8	-15	+15
HCP (6 Sides)	A	A	A	A	/	/	/	/	/	/
VCP (4 Sides)	A	A	A	A	/	/	/	/	/	/

Test Result: Pass



9. Continuous RF electromagnetic field Disturbances (RS)

9.1 Test Procedure

Test is conducted under the description of EN 61000-4-3.

9.2 Test Performance

Performance Criterion: A

9.3 Environmental Conditions

Temperature:	22.5°C
Relative Humidity:	54 %
ATM Pressure:	1010 mbar

9.4 Basic Test Setup Block Diagram

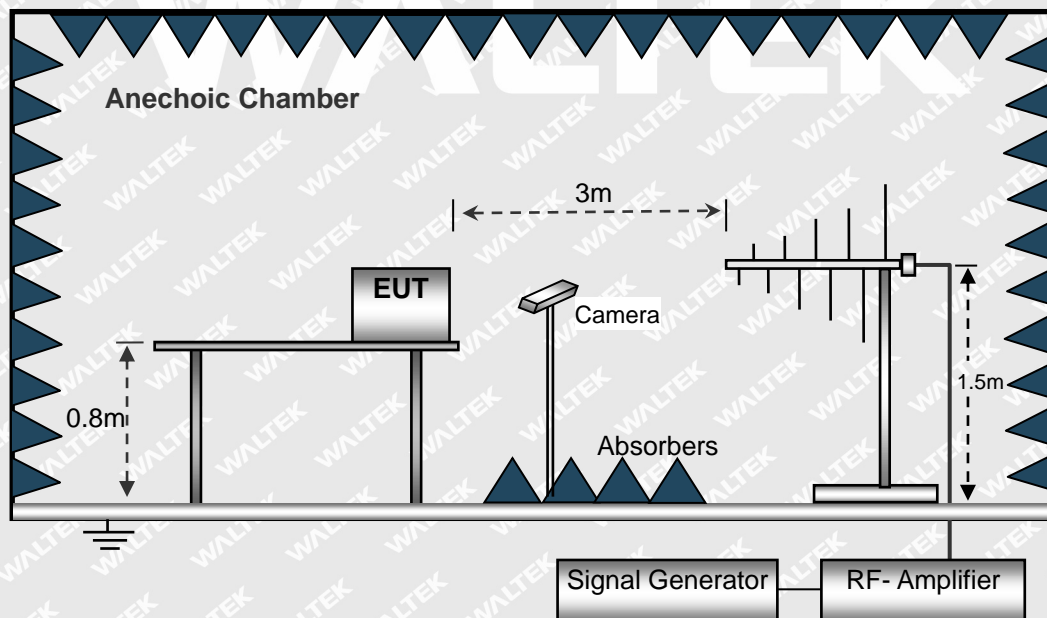



9.5 Continuous Radiated Disturbances Test Data

Frequency step: 1% of fundamental

Dwell time: 1 second

Modulation: AM by 1kHz sine wave with 80% modulation depth

Test Mode: TM1

Frequency Range(MHz)	Field (V/m)	Front		Rear		Left Side		Right Side	
		VERT	HORI	VERT	HORI	VERT	HORI	VERT	HORI
80-1000	3	A	A	A	A	A	A	A	A

Test Result: Pass

WALTEK



10. Electrical Fast Transients (EFT)

10.1 Test Procedure

Test is conducted under the description of EN 61000-4-4.

10.2 Test Performance

Performance Criterion: B

10.3 Environmental Conditions

Temperature:	22.5 °C
Relative Humidity:	54 %
ATM Pressure:	1011 mbar

10.4 Basic Test Setup Block Diagram

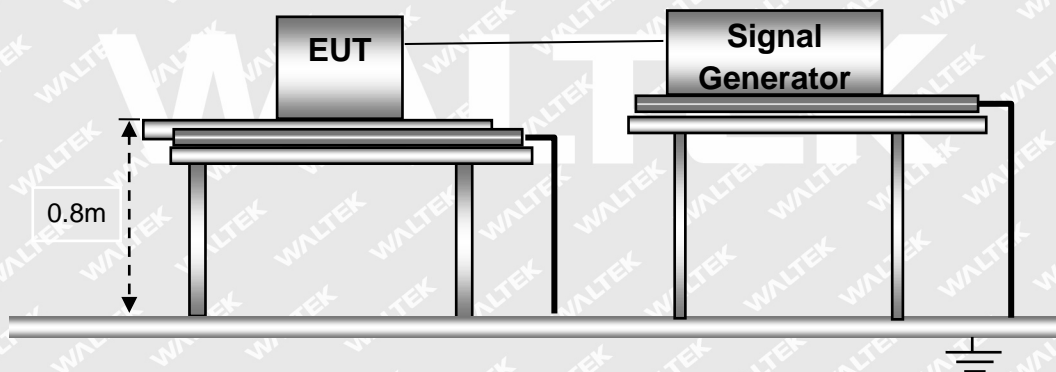



10.5 Electrical Fast Transients Test Data

Test Mode: TM1

EN 61000-4-4 Test Points		Test Voltage (kV)							
		+0.5	-0.5	+1.0	-1.0	+2.0	-2.0	+4.0	-4.0
Power Supply Power Port of EUT	L1	/	/	A	A	/	/	/	/
	L2	/	/	A	A	/	/	/	/
	PE	/	/	/	/	/	/	/	/
	L1+L2	/	/	A	A	/	/	/	/
	L1 + PE	/	/	/	/	/	/	/	/
	L2 + PE	/	/	/	/	/	/	/	/
	L1+L2+PE	/	/	/	/	/	/	/	/
Signal ports	RJ45	/	/	/	/	/	/	/	/

Test Result: Pass

WALTEK



11. Surges

11.1 Test Procedure

Test is conducted under the description of EN 61000-4-5.

11.2 Test Performance

Performance Criterion: C

11.3 Environmental Conditions

Temperature:	22.5°C
Relative Humidity:	54 %
ATM Pressure:	1011 mbar

11.4 Basic Test Setup Block Diagram

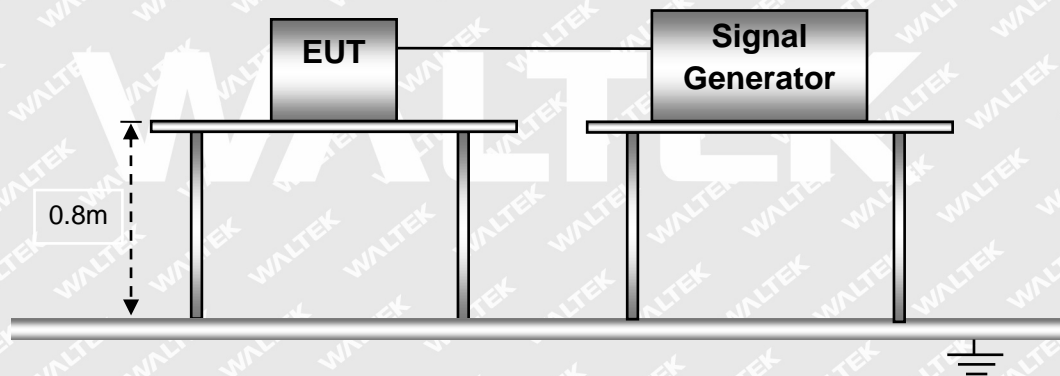

**11.5 Surge Test Data**

Test Mode: TM1

Test Voltage	Poll	Path	Pass	Fail
0.5kV	±	L-N	A	/
1kV	±	L-N	/	/
2kV	±	L-PE, N-PE	/	/
4kV	±	L-N, L-PE, N-PE	/	/

Test Result: Pass

WALTEK



12. Continuous Induced RF Disturbances (C/S)

12.1 Test Procedure

Test is conducted under the description of EN 61000-4-6.

12.2 Test Performance

Performance Criterion: A

12.3 Environmental Conditions

Temperature:	22.5°C
Relative Humidity:	54 %
ATM Pressure:	1011 mbar

12.4 Basic Test Setup Block Diagram

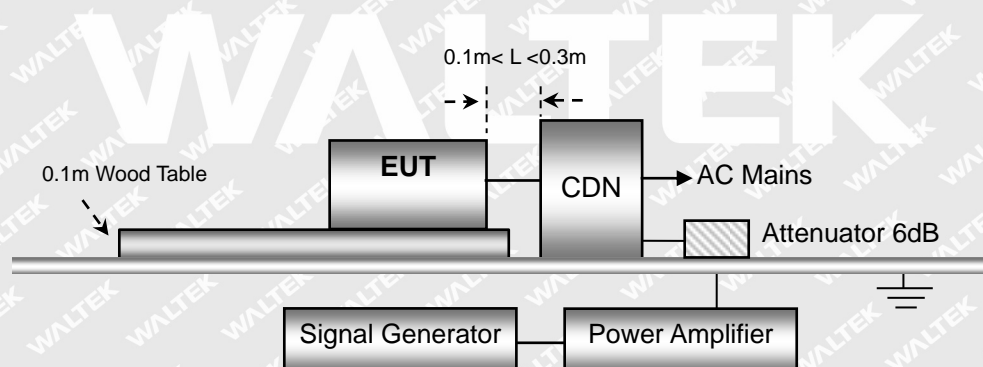



12.5 Continuous Conducted Disturbances Test Data

Sweep frequency range: 0.15 MHz to 80 MHz

Frequency step: 1% of fundamental

Dwell time: 1 second

Test Mode: TM1

AC Port

Frequency MHz	Injected Position	Voltage level (e.m.f.)	Observations (Performance Criterion)	Result
0.15-80	AC Mains	1V	/	/
0.15-80	AC Mains	3V	A	Pass
0.15-80	AC Mains	10V	/	/

Test Result: Pass

WALTEK



13. Power-Frequency Magnetic Fields (PFMF)

13.1 Test Procedure

Test is conducted under the description of EN 61000-4-8.

13.2 Test Performance

Performance Criterion: A

13.3 Environmental Conditions

Temperature:	22.5 °C
Relative Humidity:	54 %
ATM Pressure:	1011 mbar

13.4 Basic Test Setup Block Diagram

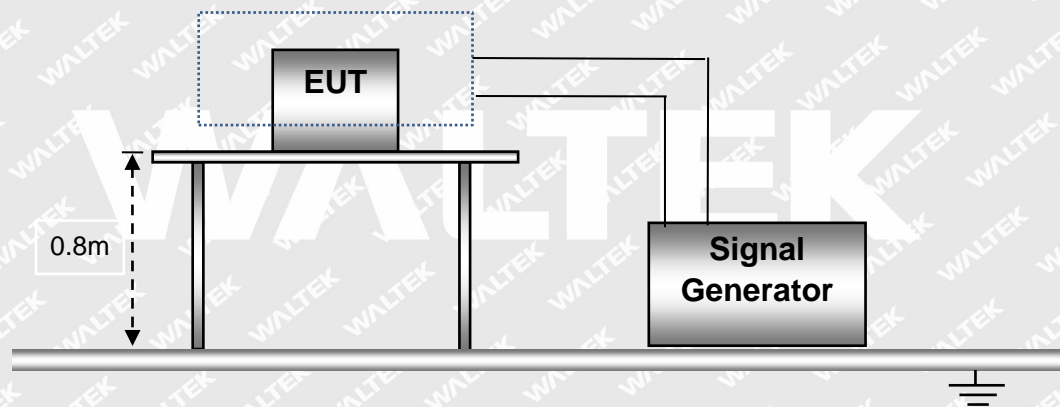

**13.5 Power-Frequency Magnetic Field Test Data**

Test Mode: TM1

Level	Magnetic Field Strength (r.m.s) A/m	Frequency Hz	Induction Coil Position	Pass	Fail
1	1	50	X, Y, Z	/	/
2	3	50	X, Y, Z	A	/
3	10	50	X, Y, Z	/	/
X	Special	/	/	/	/

Test Result: Pass

WALTEK



14. Voltage Dips and Interruptions

14.1 Test Procedure

Test is conducted under the description of EN 61000-4-11.

14.2 Test Performance

Performance Criterion: B/C

14.3 Environmental Conditions

Temperature:	22.5°C
Relative Humidity:	54 %
ATM Pressure:	1011 mbar

14.4 Basic Test Setup Block Diagram

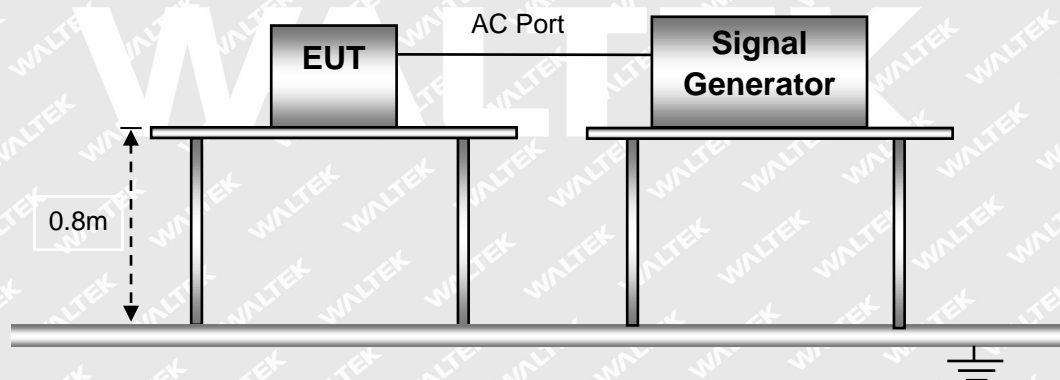



14.5 Voltage Dips And Interruptions Test Data

Test Mode: TM1

U: Vlotage dips in % U_T (U_T is rated voltage for the EUT)

T: Test duration

Level	U	T	Phase Angle	N	Pass	Fail
1	30%	200ms	0/90/180/270	3	A	/
2	100%	10ms	0/90/180/270	3	A	/

Test Result: Pass

WALTEK



EXHIBIT 1 - EUT PHOTOGRAPHS

Please refer to “ANNEX”.

WALTEK

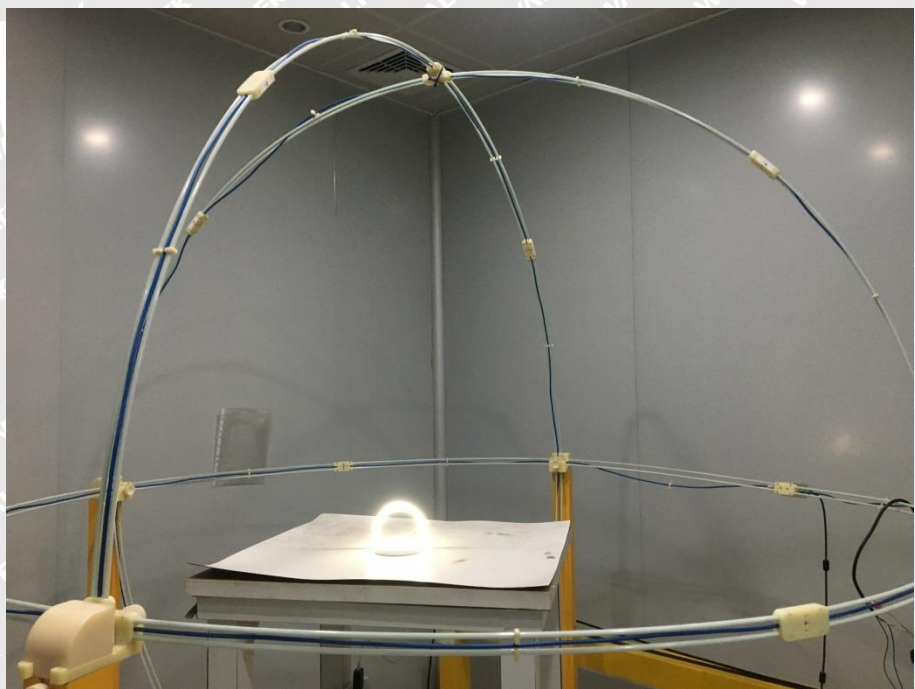

EXHIBIT 2 - TEST SETUP PHOTOGRAPHS

**Conducted Emission
Test Setup**



**Radiation Emission Test
View (9kHz~30MHz)**





**Radiation Emission Test
View
(30MHz~1000MHz)**



Flicker Test View





EN 61000-4-2 Test View

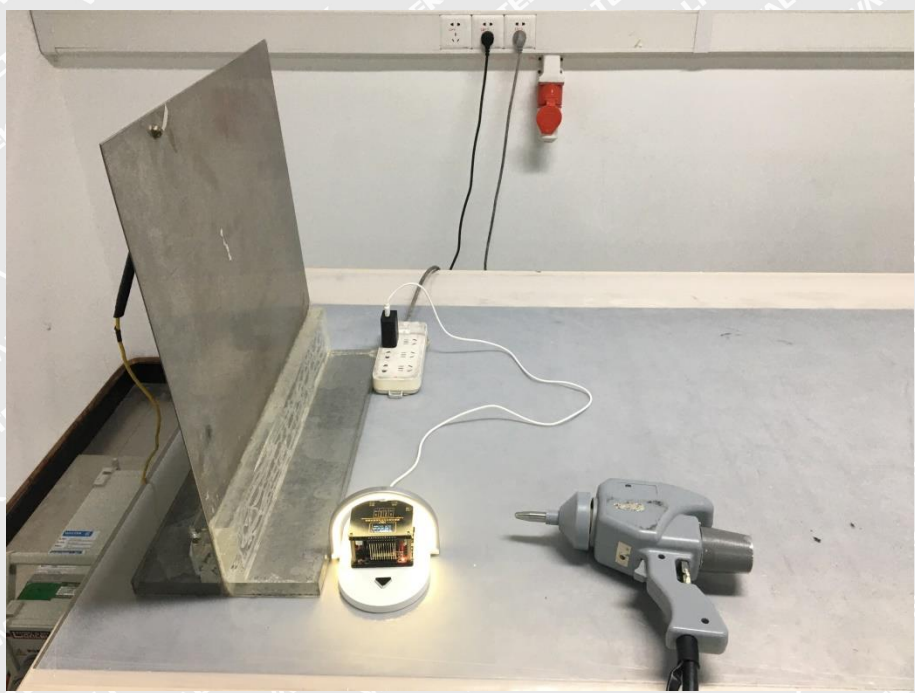

EN 61000-4-3 Test View

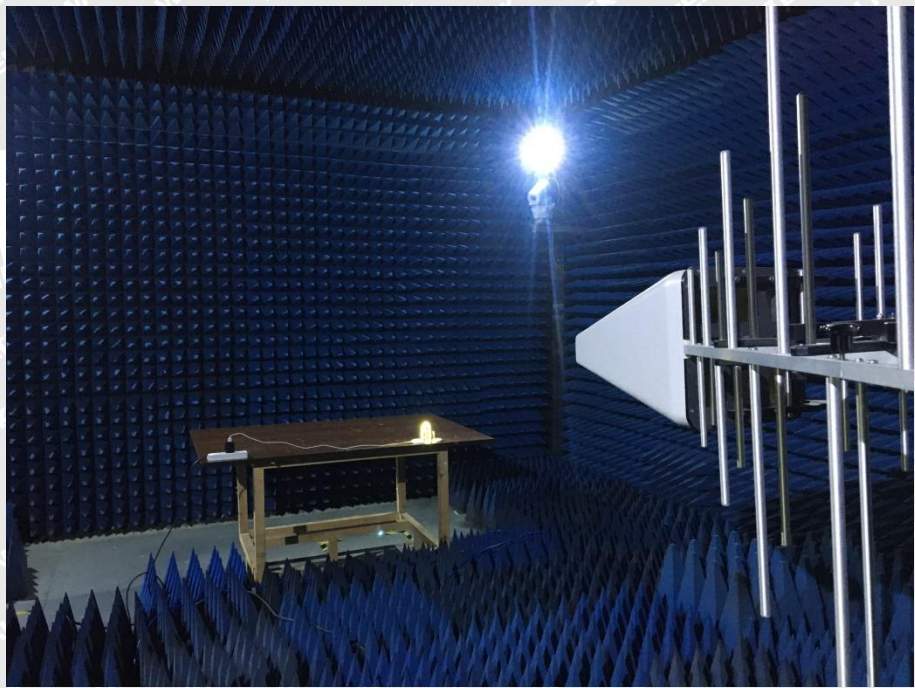



EN 61000-4-4/5/11 Test View

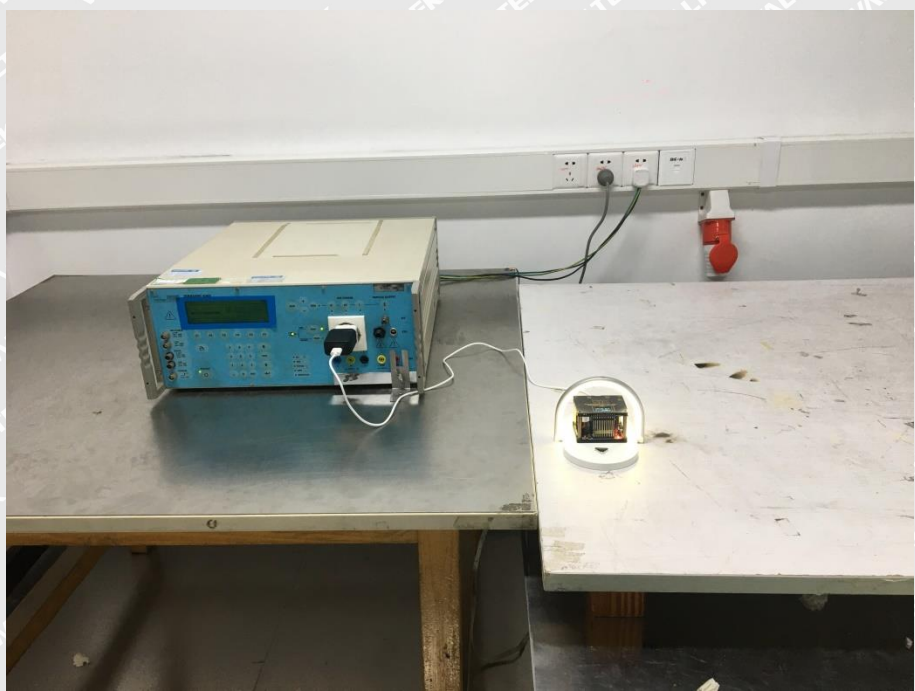

EN 61000-4-6 Test View



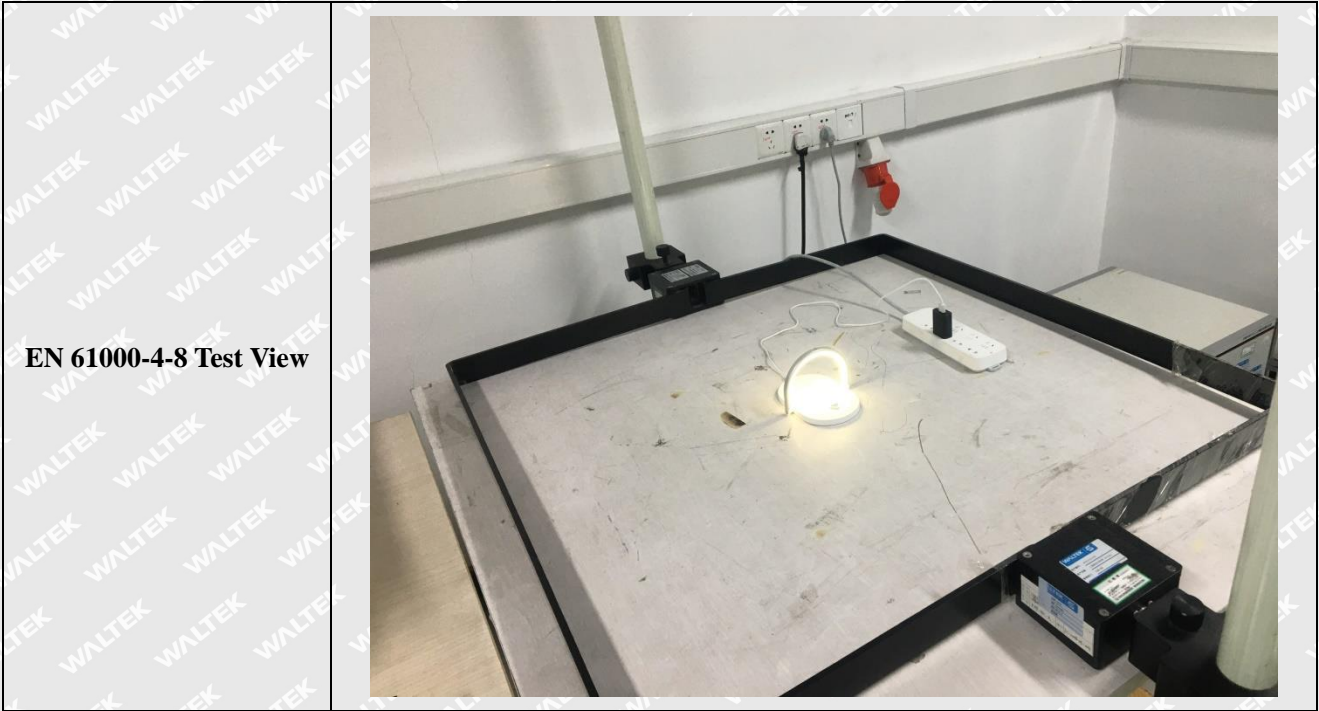

EN 61000-4-8 Test View

******* END OF REPORT *******

WALTEK