

---

# EMC Test Report

---

Report No.: AGC05443220510EE01

**PRODUCT DESIGNATION** : Rechargeable LED Ring Light Clip for smartphone

**BRAND NAME** : N/A

**MODEL NAME** : MO6595

**APPLICANT** : MID OCEAN BRANDS B.V

**DATE OF ISSUE** : May 16, 2022

**STANDARD(S)** : EN IEC 55015:2019+A11:2020  
EN IEC 61000-3-2:2019  
EN 61000-3-3:2013+A1:2019  
EN 61547:2009

**REPORT VERSION** : V1.0



Attestation of Global Compliance (Shenzhen) Co., Ltd



Any report having not been signed by authorized approver, or having been altered without authorization, or having not been stamped by the "Dedicated Testing/Inspection Stamp" is deemed to be invalid. Copying or excerpting portion of, or altering the content of the report is not permitted without the written authorization of AGC. The test results presented in the report apply only to the tested sample. Any objections to report issued by AGC should be submitted to AGC within 15days after the issuance of the test report. Further enquiry of validity or verification of the test report should be addressed to AGC by [agc01@agccert.com](mailto:agc01@agccert.com).

**REPORT REVISE RECORD**

Report Version	Revise Time	Issued Date	Valid Version	Notes
V1.0	/	May 16, 2022	Valid	Initial release

Any report having not been signed by authorized approver, or having been altered without authorization, or having not been stamped by the "Dedicated Testing/Inspection Stamp" is deemed to be invalid. Copying or excerpting portion of, or altering the content of the report is not permitted without the written authorization of AGC. The test results presented in the report apply only to the tested sample. Any objections to report issued by AGC should be submitted to AGC within 15days after the issuance of the test report. Further enquiry of validity or verification of the test report should be addressed to AGC by agc01@agccert.com.

## TABLE OF CONTENTS

<b>1 VERIFICATION OF CONFORMITY</b> .....	<b>6</b>
<b>2 SYSTEM DESCRIPTION</b> .....	<b>7</b>
<b>3 MEASUREMENT UNCERTAINTY</b> .....	<b>7</b>
<b>4 PRODUCT INFORMATION</b> .....	<b>8</b>
<b>5 SUPPORT EQUIPMENT</b> .....	<b>9</b>
<b>6 TEST FACILITY</b> .....	<b>10</b>
<b>7 TEST EQUIPMENT LIST</b> .....	<b>10</b>
<b>8 TEST SUMMARY LIST</b> .....	<b>12</b>
<b>9 EN IEC 55015 LINE CONDUCTED EMISSION TEST</b> .....	<b>13</b>
9.1 LIMITS OF LINE CONDUCTED EMISSION TEST AT MAINS TERMINALS .....	13
9.2 BLOCK DIAGRAM OF TEST SETUP.....	13
9.3 PROCEDURE OF LINE CONDUCTED EMISSION TEST.....	14
9.4 TEST RESULT OF LINE CONDUCTED EMISSION TEST .....	15
<b>10 EN IEC 55015 RADIATED EMISSION TEST</b> .....	<b>17</b>
10.1 LIMITS OF RADIATED DISTURBANCES.....	17
10.2 BLOCK DIAGRAM OF TEST SETUP.....	17
10.3 PROCEDURE OF RADIATED EMISSION TEST.....	18
10.4 TEST RESULT OF RADIATED EMISSION TEST .....	19
<b>11 EN IEC 55015 RADIATED ELECTROMAGNETIC DISTURBANCE TEST</b> .....	<b>21</b>
11.1 LIMITS OF RADIATED ELECTROMAGNETIC DISTURBANCE IN THE RANGE 9 KHZ TO 30 MHZ .....	21
11.2 BLOCK DIAGRAM OF TEST SETUP .....	22
11.3 TEST PROCEDURE.....	22
11.4 TEST RESULTS OF RADIATED ELECTROMAGNETIC DISTURBANCE .....	23
<b>12 EN IEC 61000-3-2 POWER HARMONICS TEST</b> .....	<b>26</b>
12.1 BLOCK DIAGRAM OF TEST SETUP.....	26
12.2 RESULT.....	26

Any report having not been signed by authorized approver, or having been altered without authorization, or having not been stamped by the “Dedicated Testing/Inspection Stamp” is deemed to be invalid. Copying or excerpting portion of, or altering the content of the report is not permitted without the written authorization of AGC. The test results presented in the report apply only to the tested sample. Any objections to report issued by AGC should be submitted to AGC within 15days after the issuance of the test report. Further enquiry of validity or verification of the test report should be addressed to AGC by [agc01@agccert.com](mailto:agc01@agccert.com).

<b>13 EN 61000-3-3 VOLTAGE FLUCTUATION / FLICKER TEST .....</b>	<b>27</b>
13.1 BLOCK DIAGRAM OF TEST SETUP .....	27
13.2 RESULT .....	28
<b>14 EN 61000-4-2 ESD IMMUNITY TEST .....</b>	<b>29</b>
14.1 BLOCK DIAGRAM OF TEST SETUP .....	29
14.2 TEST PROCEDURE .....	30
14.3 PERFORMANCE & RESULT .....	31
<b>15 EN 61000-4-3 RS IMMUNITY TEST .....</b>	<b>32</b>
15.1 BLOCK DIAGRAM OF TEST SETUP .....	32
15.2 TEST PROCEDURE .....	33
15.3 PERFORMANCE & RESULT .....	34
<b>16 EN 61000-4-4 EFT IMMUNITY TEST .....</b>	<b>35</b>
16.1 BLOCK DIAGRAM OF TEST SETUP .....	35
16.2 TEST PROCEDURE .....	36
16.3 PERFORMANCE & RESULT .....	36
<b>17 EN 61000-4-5 SURGE IMMUNITY TEST .....</b>	<b>37</b>
17.1 BLOCK DIAGRAM OF TEST SETUP .....	37
17.2 TEST PROCEDURE .....	38
17.3 PERFORMANCE & RESULT .....	38
<b>18 EN 61000-4-6 CS IMMUNITY TEST .....</b>	<b>39</b>
18.1 BLOCK DIAGRAM OF TEST SETUP .....	39
18.2 TEST PROCEDURE .....	40
18.3 PERFORMANCE & RESULT .....	40
<b>19 EN 61000-4-8 PFMF TEST .....</b>	<b>41</b>
19.1 BLOCK DIAGRAM OF TEST SETUP .....	41
19.2 TEST PROCEDURE .....	42
19.3 PERFORMANCE & RESULT .....	42
<b>20 EN 61000-4-11 DIPS IMMUNITY TEST .....</b>	<b>43</b>
20.1 BLOCK DIAGRAM OF TEST SETUP .....	43
20.2 TEST PROCEDURE .....	44
20.3 INTERPRETATION .....	44

Any report having not been signed by authorized approver, or having been altered without authorization, or having not been stamped by the “Dedicated Testing/Inspection Stamp” is deemed to be invalid. Copying or excerpting portion of, or altering the content of the report is not permitted without the written authorization of AGC. The test results presented in the report apply only to the tested sample. Any objections to report issued by AGC should be submitted to AGC within 15days after the issuance of the test report. Further enquiry of validity or verification of the test report should be addressed to AGC by [agc01@agccert.com](mailto:agc01@agccert.com).

**APPENDIX A: PHOTOGRAPHS OF TEST SETUP ..... 45**

**APPENDIX B: PHOTOGRAPHS OF EUT ..... 50**

Any report having not been signed by authorized approver, or having been altered without authorization, or having not been stamped by the “Dedicated Testing/Inspection Stamp” is deemed to be invalid. Copying or excerpting portion of, or altering the content of the report is not permitted without the written authorization of AGC. The test results presented in the report apply only to the tested sample. Any objections to report issued by AGC should be submitted to AGC within 15days after the issuance of the test report. Further enquiry of validity or verification of the test report should be addressed to AGC by [agc01@agccert.com](mailto:agc01@agccert.com).

Attestation of Global Compliance(Shenzhen)Co., Ltd  
Attestation of Global Compliance(Shenzhen)Std & Tech Co., Ltd  
Tel: +86-755 2523 4088 E-mail: [agc@agccert.com](mailto:agc@agccert.com) Web: <http://www.agccert.com/>

## 1 VERIFICATION OF CONFORMITY

<b>Applicant</b>	MID OCEAN BRANDS B.V
<b>Address</b>	7/F, Kings Tower, 111 King Lam Street, Cheung Sha Wan, Kowloon, Hong Kong
<b>Manufacturer</b>	MID OCEAN BRANDS B.V
<b>Address</b>	7/F, Kings Tower, 111 King Lam Street, Cheung Sha Wan, Kowloon, Hong Kong
<b>Factory</b>	MID OCEAN BRANDS B.V
<b>Address</b>	7/F, Kings Tower, 111 King Lam Street, Cheung Sha Wan, Kowloon, Hong Kong
<b>Product Designation</b>	Rechargeable LED Ring Light Clip for smartphone
<b>Brand Name</b>	N/A
<b>Test Model</b>	MO6595
<b>Date of test</b>	May 07, 2022 to May 16, 2022
<b>Deviation</b>	The sample has no any deviation to the method of standard mentioned on page 1
<b>Condition of Test Sample</b>	Normal
<b>Test Result</b>	Pass

The above equipment was tested by Attestation of Global Compliance (Shenzhen) Co., Ltd. for compliance with the requirements set forth in the Technical Standards mentioned above. This said equipment in the configuration described in this report shows the maximum emission levels emanating from equipment and the level of the immunity endurance of the equipment are within the compliance requirements.

The test results of this report relate only to the tested sample identified in this report.

Prepared By   
 \_\_\_\_\_  
 Jack Gui  
 (Project Engineer) May 16, 2022

Reviewed By   
 \_\_\_\_\_  
 Calvin Liu  
 (Reviewer) May 16, 2022

Approved By   
 \_\_\_\_\_  
 Forrest Lei  
 (Authorized Officer) May 16, 2022

Any report having not been signed by authorized approver, or having been altered without authorization, or having not been stamped by the "Dedicated Testing/Inspection Stamp" is deemed to be invalid. Copying or excerpting portion of, or altering the content of the report is not permitted without the written authorization of AGC. The test results presented in the report apply only to the tested sample. Any objections to report issued by AGC should be submitted to AGC within 15days after the issuance of the test report. Further enquiry of validity or verification of the test report should be addressed to AGC by agc01@agccert.com.

## 2 SYSTEM DESCRIPTION

TEST MODE DESCRIPTION		
NO.	TEST MODE DESCRIPTION	WORST
1	Natural Light with adapter	V
2	White Light with adapter	--
3	Yellow Light with adapter	--

Note:  
 1. V means EMI worst mode.  
 2. Only worst mode data recorded in the test report.

## 3 MEASUREMENT UNCERTAINTY

The uncertainty is calculated using the methods suggested in the “Guide to the Expression of Uncertainty in measurement” (GUM) published by ISO.

- Uncertainty of Conducted Emission,  $U_c = \pm 2.9\text{dB}$
- Uncertainty of Radiated Emission,  $U_c = \pm 3.8\text{dB}$

Any report having not been signed by authorized approver, or having been altered without authorization, or having not been stamped by the “Dedicated Testing/Inspection Stamp” is deemed to be invalid. Copying or excerpting portion of, or altering the content of the report is not permitted without the written authorization of AGC. The test results presented in the report apply only to the tested sample. Any objections to report issued by AGC should be submitted to AGC within 15days after the issuance of the test report. Further enquiry of validity or verification of the test report should be addressed to AGC by [agc01@agccert.com](mailto:agc01@agccert.com).

#### 4 PRODUCT INFORMATION

<b>Housing Type</b>	Plastic and metal
<b>EUT Input Rating</b>	DC 3.7V by battery or DC 5V by adapter
<b>Hardware Version</b>	N/A
<b>Software Version</b>	N/A

I/O Port Information ( Applicable  Not Applicable)

I/O Port of EUT			
I/O Port Type	Number	Cable Description	Tested With
Micro-B	1	0.3m unshielded	1

Any report having not been signed by authorized approver, or having been altered without authorization, or having not been stamped by the "Dedicated Testing/Inspection Stamp" is deemed to be invalid. Copying or excerpting portion of, or altering the content of the report is not permitted without the written authorization of AGC. The test results presented in the report apply only to the tested sample. Any objections to report issued by AGC should be submitted to AGC within 15days after the issuance of the test report. Further enquiry of validity or verification of the test report should be addressed to AGC by agc01@agccert.com.

## 5 SUPPORT EQUIPMENT

Device Type	Manufacturer	Model Name	Serial No.	Data Cable	Power Cable
Adapter	jinbaotong	K-T10E0502000E	--	--	--

Note: All the above equipment/cables were placed in worse case positions to maximize emission signals during emission test.

## 6 TEST FACILITY

<b>Site</b>	Attestation of Global Compliance (Shenzhen) Co., Ltd
<b>Location</b>	1-2/F, Building 19, Junfeng Industrial Park, Chongqing Road, Heping Community, Fuhai Street, Bao 'an District, Shenzhen, Guangdong, China

## 7 TEST EQUIPMENT LIST

### TEST EQUIPMENT OF CONDUCTED EMISSION TEST

Equipment	Manufacturer	Model	S/N	Cal. Date	Cal. Due
Test Receiver	R&S	ESPI	101206	Mar. 28, 2022	Mar. 27, 2023
LISN	R&S	ESH2-Z5	100086	Jun. 09, 2021	Jun. 08, 2022
Test software	R&S	ES-K1 (Ver V1.71)	N/A	N/A	N/A

### TEST EQUIPMENT OF RADIATED EMISSION TEST

Equipment	Manufacturer	Model	S/N	Cal. Date	Cal. Due
Test Receiver	R&S	ESCI	10096	Mar. 28, 2022	Mar. 27, 2023
Antenna	SCHWARZBECK	VULB9168	494	Jan. 08, 2021	Jan. 07, 2023
Test software	Tonscend	JS32-RE (Ver. 2.5)	N/A	N/A	N/A

### TEST EQUIPMENT OF RADIATED ELECTROMAGNETIC DISTURBANCE TEST

Equipment	Manufacturer	Model	S/N	Cal. Date	Cal. Due
Triple Loop Antenna	LAPLACE	RF300	9070	Jul. 26, 2021	Jul. 25, 2022
Test Receiver	R&S	ESCI	10096	Mar. 28, 2022	Mar. 27, 2023

### TEST EQUIPMENT OF POWER HARMONICS / VOLTAGE FLUCTUATION / FLICKER TEST

Equipment	Manufacturer	Model	S/N	Cal. Date	Cal. Due
Signal Conditioning Unit	Schaffner	CCN1000-1	72431	Jul. 15, 2020	Jul. 14, 2022
AC Source	Schaffner	NSG1007	56825	Jul. 15, 2020	Jul. 14, 2022

Any report having not been signed by authorized approver, or having been altered without authorization, or having not been stamped by the "Dedicated Testing/Inspection Stamp" is deemed to be invalid. Copying or excerpting portion of, or altering the content of the report is not permitted without the written authorization of AGC. The test results presented in the report apply only to the tested sample. Any objections to report issued by AGC should be submitted to AGC within 15days after the issuance of the test report. Further enquiry of validity or verification of the test report should be addressed to AGC by [agc01@agccert.com](mailto:agc01@agccert.com).

**TEST EQUIPMENT OF SURGE/EFT/DIPS TEST**

Description	Manufacturer	Model	S/N	Cal. Date	Cal. Due
EFT Surge Generator	Schaffner	Modula 6150	34437	Jul. 19, 2021	Jul. 18, 2022

**TEST EQUIPMENT OF ESD TEST**

Equipment	Manufacturer	Model	S/N	Cal. Date	Cal. Due
ESD Simulator	Schaffner	NSG 438	782	Jan. 08, 2022	Jan. 07, 2023

**TEST EQUIPMENT OF RS IMMUNITY TEST**

Description	Manufacturer	Model	S/N	Cal. Date	Cal. Due
Signal Generator	R&S	E4421B	MY43351603	Mar. 04, 2022	Mar. 03, 2023
Power Sensor	R&S	URV5-Z4	100124	Apr. 26, 2021	Apr. 25, 2023
Power Meter	R&S	NRVD	8323781027	Apr. 26, 2021	Apr. 25, 2023
Power Amplifier	KALMUS	7100LC	04-02/17-06-00 1	N/A	N/A
Power Amplifier	Milmega	AS0104-55_55	1004793	N/A	N/A
Broadband Preamplifier	SCHWARZBEC K	VULB9168	D69250	Sep. 19, 2021	Sep. 18, 2023

**TEST EQUIPMENT OF CS IMMUNITY TEST**

Description	Manufacturer	Model	S/N	Cal. Date	Cal. Due
Power Amplifier	AR	75A250	18464	N/A	N/A
CDN	ZHINAN	ZN3751	15004	Sep. 03, 2020	Sep. 02, 2022
6dB attenuator	ZHINAN	E-002	N/A	Sep. 03, 2020	Sep. 02, 2022
Power Sensor	R&S	URV5-Z4	100124	Apr. 26, 2021	Apr. 25, 2023
Power Meter	R&S	NRVD	8323781027	Apr. 26, 2021	Apr. 25, 2023
Signal Generator	R&S	E4421B	MY43351603	Mar. 04, 2022	Mar. 03, 2023

**TEST EQUIPMENT OF PFMF TEST**

Description	Manufacturer	Model	Identifier	Cal. Date	Cal. Due
PFMF system	HTEC	HPFMF	161701	Jul. 19, 2021	Jul. 18, 2022

Any report having not been signed by authorized approver, or having been altered without authorization, or having not been stamped by the "Dedicated Testing/Inspection Stamp" is deemed to be invalid. Copying or excerpting portion of, or altering the content of the report is not permitted without the written authorization of AGC. The test results presented in the report apply only to the tested sample. Any objections to report issued by AGC should be submitted to AGC within 15days after the issuance of the test report. Further enquiry of validity or verification of the test report should be addressed to AGC by agc01@agccert.com.

## 8 TEST SUMMARY LIST

Test item	Test Requirement	Test Method	Class/Severity	Result
CONDUCTED EMISSION	EN IEC 55015	EN IEC 55015	0.009MHz -30MHz	Pass
RADIATED EMISSION	EN IEC 55015	EN IEC 55015	30MHz -1000MHz	Pass
RADIATED ELECTROMAGNETIC DISTURBANCE	EN IEC 55015	EN IEC 55015	0.009MHz -30MHz	Pass
Harmonic current emission	EN IEC 61000-3-2	EN IEC 61000-3-2	Class C	N/A
Voltage fluctuations & flicker	EN 61000-3-3	EN 61000-3-3	§5 of EN 61000-3-3	Pass
Electrostatic Discharge Immunity	EN 61547	EN 61000-4-2	± 8.0 kV (Air Discharge) ± 4.0 kV (Contact Discharge) ± 4.0 kV (Indirect Discharge)	Pass
Radiated RF Electromagnetic	EN 61547	EN 61000-4-3	3V/m with 80% AM. 1kHz Modulation.	Pass
Electrical fast transient/burst Immunity	EN 61547	EN 61000-4-4	+/- 1kV for Power Supply Lines	Pass
SURGE IMMUNITY	EN 61547	EN 61000-4-5	>25W +/-1kV (Line to Line) +/-2kV (Line to Ground) <25W +/-0.5kV (Line to Line) +/-1kV (Line to Ground)	Pass
Immunity to Conducted Disturbances Induced by RF fields	EN 61547	EN 61000-4-6	3V with 80% AM. 1 kHz Modulation	Pass
Power Frequency Magnetic Fields	EN 61547	EN 61000-4-8	50/60 Hz, 3A/m	Pass
Voltage dips and short interruptions immunity	EN 61547	EN 61000-4-11	PHASE ANGLE 0, 45, 90, 135, 180, 225, 270, 315 degrees	Pass

**Note :** N/A means not applicable.

Any report having not been signed by authorized approver, or having been altered without authorization, or having not been stamped by the "Dedicated Testing/Inspection Stamp" is deemed to be invalid. Copying or excerpting portion of, or altering the content of the report is not permitted without the written authorization of AGC. The test results presented in the report apply only to the tested sample. Any objections to report issued by AGC should be submitted to AGC within 15days after the issuance of the test report. Further enquiry of validity or verification of the test report should be addressed to AGC by agc01@agccert.com.

## 9 EN IEC 55015 LINE CONDUCTED EMISSION TEST

### 9.1 LIMITS OF LINE CONDUCTED EMISSION TEST AT MAINS TERMINALS

Frequency Range	Maximum RF Line Voltage	
	Q.P.( dBuV)	Average( dBuV)
9 KHz-50 KHz	110	--
50 KHz-150 KHz	90-80	--
150 kHz-500 kHz	66-56	56-46
500 kHz-5.0 MHz	56	46
5.0 MHz-30.0 MHz	60	50

Note:

1. At the transition frequency, the lower limit applies.
2. The limit decreases linearly with the logarithm of the frequency in the range 50 KHz to 150 KHz and 150 KHz to 0.5 MHz.

### 9.2 BLOCK DIAGRAM OF TEST SETUP

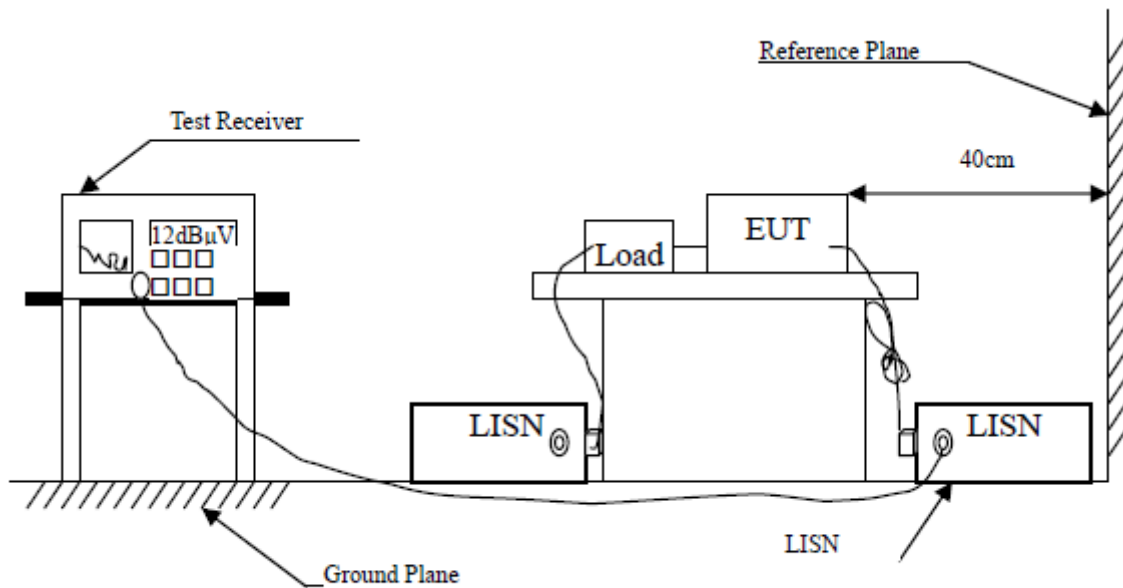

Any report having not been signed by authorized approver, or having been altered without authorization, or having not been stamped by the "Dedicated Testing/Inspection Stamp" is deemed to be invalid. Copying or excerpting portion of, or altering the content of the report is not permitted without the written authorization of AGC. The test results presented in the report apply only to the tested sample. Any objections to report issued by AGC should be submitted to AGC within 15days after the issuance of the test report. Further enquiry of validity or verification of the test report should be addressed to AGC by [agc01@agccert.com](mailto:agc01@agccert.com).

### 9.3 PROCEDURE OF LINE CONDUCTED EMISSION TEST

- (1) The equipment was set up as per the test configuration to simulate typical actual usage per the user's manual. When the EUT is a tabletop system, a wooden table with a height of 0.8 meters is used and is placed on the ground plane as per EN IEC 55015 (see Test Facility for the dimensions of the ground plane used). When the EUT is a floor-standing equipment, it is placed on the ground plane which has a 10cm non-conductive covering to insulate the EUT from the ground plane.
- (2) Support equipment, if needed, was placed as per EN IEC 55015.
- (3) All I/O cables were positioned to simulate typical actual usage as per EN IEC 55015.
- (4) The EUT received DC 5V from adapter which received AC 230V 50Hz power through a Line Impedance Stabilization Network (LISN) which supplied power source and was grounded to the ground plane.
- (5) All support equipments received power from a second LISN supplying power of AC 230V/50Hz, if any.
- (6) The EUT test program was started. Emissions were measured on each current carrying line of the EUT using a spectrum Analyzer / Receiver connected to the LISN powering the EUT. The LISN has two monitoring points: Line 1 (Hot Side) and Line 2 (Neutral Side). Two scans were taken: one with Line 1 connected to Analyzer / Receiver and Line 2 connected to a 50 ohm load; the second scan had Line 1 connected to a 50 ohm load and Line 2 connected to the Analyzer / Receiver.
- (7) Analyzer / Receiver scanned from 9 kHz to 30 MHz for emissions in each of the test modes.
- (8) During the above scans, the emissions were maximized by cable manipulation.
- (9) The test mode(s) were scanned during the test
- (10) A scan was taken on both power lines, Line 1 and Line 2, recording at least the six highest emissions.
- (11) Emission frequency and amplitude were recorded into a computer in which correction factors were used to calculate the emission level and compare reading to the applicable limit. If EUT emission level was less -2dB to the A.V. limit in Peak mode, then the emission signal was re-checked using Q.P and Average detector.

### 9.4 TEST RESULT OF LINE CONDUCTED EMISSION TEST

#### LINE CONDUCTED EMISSION TEST-L

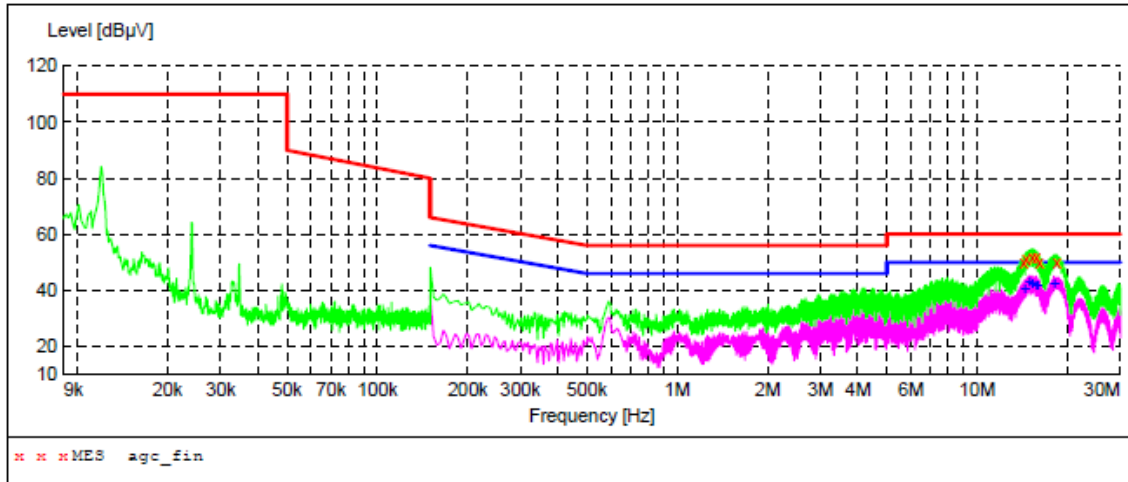

**MEASUREMENT RESULT: "agc\_fin"**

Frequency MHz	Level dBµV	Transd dB	Limit dBµV	Margin dB	Detector	Line
14.294000	49.80	8.1	60	10.2	QP	L1
14.574000	50.90	8.2	60	9.1	QP	L1
15.238000	52.00	8.3	60	8.0	QP	L1
15.774000	51.50	8.4	60	8.5	QP	L1
16.114000	49.90	8.4	60	10.1	QP	L1
18.374000	49.90	8.7	60	10.1	QP	L1

**MEASUREMENT RESULT: "agc\_fin2"**

Frequency MHz	Level dBµV	Transd dB	Limit dBµV	Margin dB	Detector	Line
14.406000	40.80	8.2	50	9.2	AV	L1
14.882000	42.90	8.3	50	7.1	AV	L1
15.230000	42.60	8.3	50	7.4	AV	L1
15.714000	41.70	8.4	50	8.3	AV	L1
15.826000	41.80	8.4	50	8.2	AV	L1
18.022000	42.60	8.6	50	7.4	AV	L1

**RESULT: PASS**

Any report having not been signed by authorized approver, or having been altered without authorization, or having not been stamped by the "Dedicated Testing/Inspection Stamp" is deemed to be invalid. Copying or excerpting portion of, or altering the content of the report is not permitted without the written authorization of AGC. The test results presented in the report apply only to the tested sample. Any objections to report issued by AGC should be submitted to AGC within 15days after the issuance of the test report. Further enquiry of validity or verification of the test report should be addressed to AGC by agc01@agccert.com.

LINE CONDUCTED EMISSION TEST-N

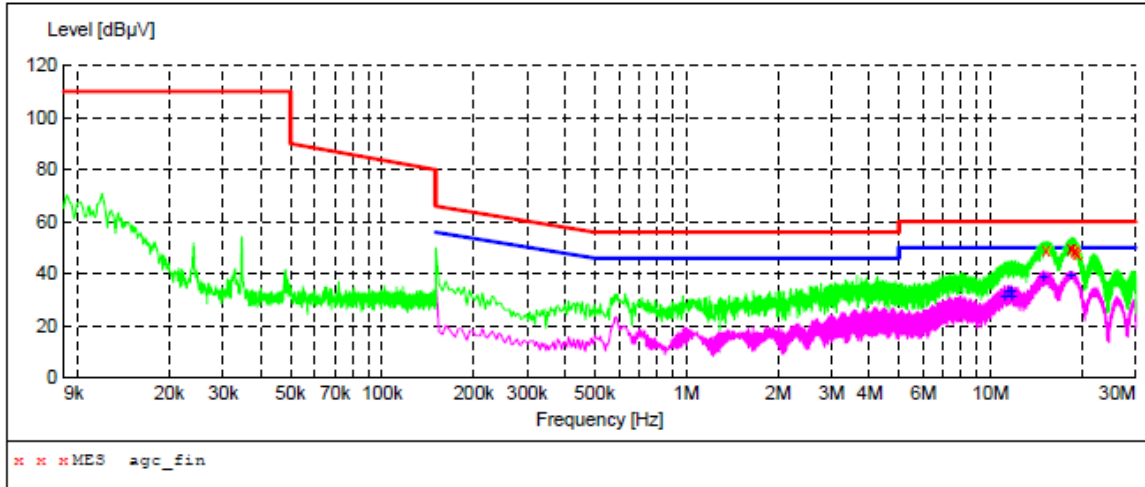

MEASUREMENT RESULT: "agc\_fin"

Frequency MHz	Level dBµV	Transd dB	Limit dBµV	Margin dB	Detector	Line
15.202000	49.20	8.3	60	10.8	QP	N
18.378000	49.50	8.7	60	10.5	QP	N
18.402000	49.50	8.7	60	10.5	QP	N
18.962000	48.70	8.7	60	11.3	QP	N
18.990000	48.60	8.7	60	11.4	QP	N
19.234000	47.50	8.7	60	12.5	QP	N

MEASUREMENT RESULT: "agc\_fin2"

Frequency MHz	Level dBµV	Transd dB	Limit dBµV	Margin dB	Detector	Line
11.090000	31.30	7.2	50	18.7	AV	N
11.398000	33.30	7.3	50	16.7	AV	N
11.686000	33.30	7.4	50	16.7	AV	N
11.698000	31.50	7.4	50	18.5	AV	N
14.906000	38.60	8.3	50	11.4	AV	N
18.250000	39.30	8.6	50	10.7	AV	N

RESULT: PASS

Any report having not been signed by authorized approver, or having been altered without authorization, or having not been stamped by the "Dedicated Testing/Inspection Stamp" is deemed to be invalid. Copying or excerpting portion of, or altering the content of the report is not permitted without the written authorization of AGC. The test results presented in the report apply only to the tested sample. Any objections to report issued by AGC should be submitted to AGC within 15days after the issuance of the test report. Further enquiry of validity or verification of the test report should be addressed to AGC by agc01@agccert.com.

## 10 EN IEC 55015 RADIATED EMISSION TEST

### 10.1 LIMITS OF RADIATED DISTURBANCES

#### AT 10M DISTANCES

Frequency (MHz)	Distance (m)	Maximum Field Strength Limit (dBuV/m Q.P.)
30-230	10	30.00
230-1000	10	37.00

#### AT 3M DISTANCES

Frequency (MHz)	Distance (m)	Maximum Field Strength Limit (dBuV/m Q.P.)
30-230	3	40.00
230-1000	3	47.00

Note: The lower limit shall apply at the transition frequency.

### 10.2 BLOCK DIAGRAM OF TEST SETUP

System Diagram of Connections between EUT and Simulators

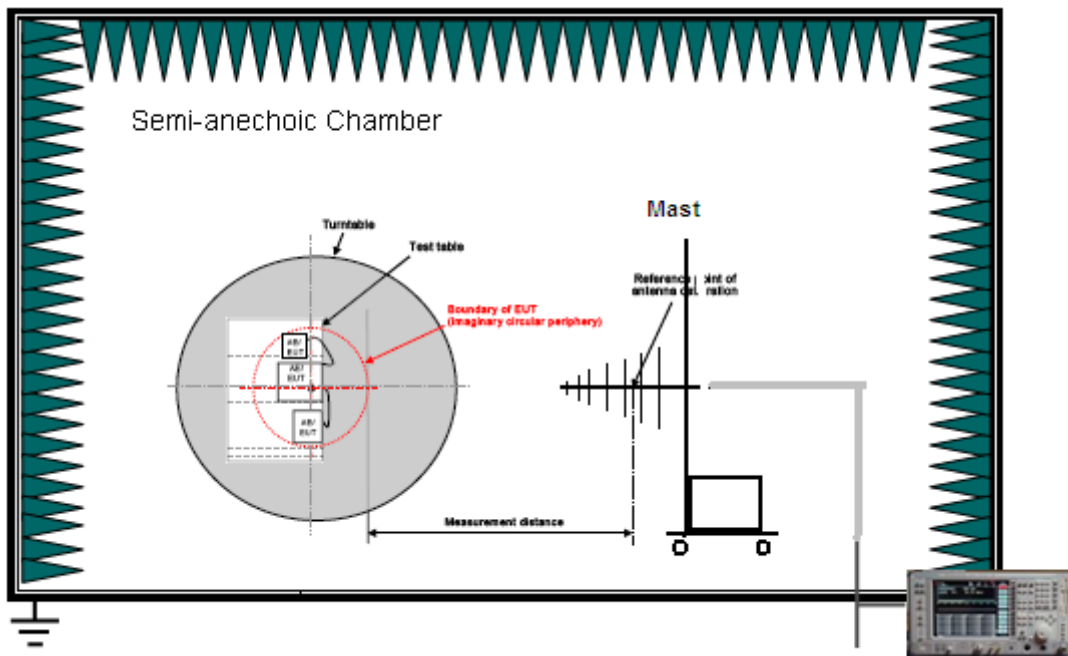

Any report having not been signed by authorized approver, or having been altered without authorization, or having not been stamped by the "Dedicated Testing/Inspection Stamp" is deemed to be invalid. Copying or excerpting portion of, or altering the content of the report is not permitted without the written authorization of AGC. The test results presented in the report apply only to the tested sample. Any objections to report issued by AGC should be submitted to AGC within 15days after the issuance of the test report. Further enquiry of validity or verification of the test report should be addressed to AGC by [agc01@agccert.com](mailto:agc01@agccert.com).

### 10.3 PROCEDURE OF RADIATED EMISSION TEST

- (1) The equipment was set up as per the test configuration to simulate typical actual usage per the user's manual. When the EUT is a tabletop system, a wooden turntable with a height of 0.8 meters is used which is placed on the ground plane as per EN IEC 55015 (see Test Facility for the dimensions of the ground plane used). When the EUT is a floor-standing equipment, it is placed on the ground plane which has a 10cm non-conductive covering to insulate the EUT from the ground plane.
- (2) Support equipment, if needed, was placed as per EN IEC 55015.
- (3) All I/O cables were positioned to simulate typical actual usage as per EN IEC 55015.
- (4) The EUT was turned on.
- (5) The antenna was placed at 3 meters away from the EUT as stated in EN IEC 55015. The antenna connected to the Analyzer via a cable and at times a pre-amplifier would be used.
- (6) The Analyzer / Receiver quickly scanned from 30MHz to 1000MHz. The EUT test program was started. Emissions were scanned and measured rotating the EUT to 360 degrees and positioning the antenna 1 to 4 meters above the ground plane, in both the vertical and the horizontal polarization, to maximize the emission reading level.
- (7) The test mode(s) were scanned during the test:
- (8) Recorded at least the six highest emissions. Emission frequency, amplitude, antenna position, polarization and turntable position were recorded into a computer in which correction factors were used to calculate the emission level and compare reading to the applicable limit and Q.P./Peak reading is presented.

### 10.4 TEST RESULT OF RADIATED EMISSION TEST

Mode3

Radiated Emission Test at 3m Distance-Horizontal

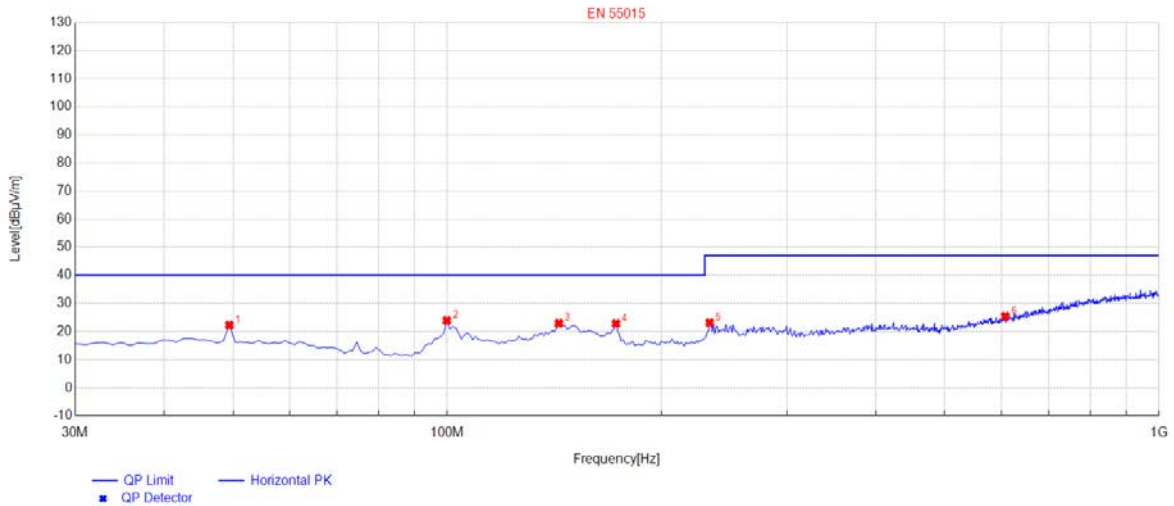

NO.	Freq. [MHz]	Level [dBµV/m]	Factor [dB]	Limit [dBµV/m]	Margin [dB]	Height [cm]	Angle [°]	Polarity
1	49.4	22.28	11.61	40.00	17.72	100	3	Horizontal
2	99.84	23.90	11.30	40.00	16.10	100	254	Horizontal
3	143.49	22.93	14.88	40.00	17.07	100	254	Horizontal
4	172.59	22.85	12.44	40.00	17.15	100	152	Horizontal
5	233.7	23.14	12.87	47.00	23.86	100	360	Horizontal
6	608.12	25.37	19.98	47.00	21.63	100	254	Horizontal

**RESULT: PASS**

Any report having not been signed by authorized approver, or having been altered without authorization, or having not been stamped by the "Dedicated Testing/Inspection Stamp" is deemed to be invalid. Copying or excerpting portion of, or altering the content of the report is not permitted without the written authorization of AGC. The test results presented in the report apply only to the tested sample. Any objections to report issued by AGC should be submitted to AGC within 15days after the issuance of the test report. Further enquiry of validity or verification of the test report should be addressed to AGC by agc01@agccert.com.

### Radiated Emission Test at 3m Distance-Vertical

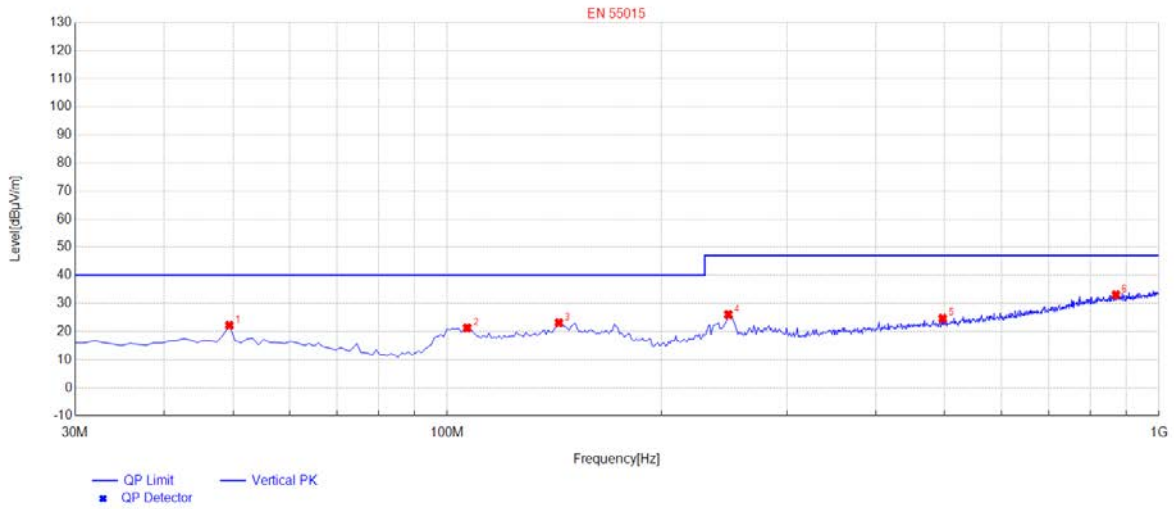

NO.	Freq. [MHz]	Level [dBμV/m]	Factor [dB]	Limit [dBμV/m]	Margin [dB]	Height [cm]	Angle [°]	Polarity
1	49.4	22.23	11.61	40.00	17.77	100	165	Vertical
2	106.63	21.29	12.07	40.00	18.71	100	123	Vertical
3	143.49	23.11	14.88	40.00	16.89	100	80	Vertical
4	248.25	25.99	14.01	47.00	21.01	100	354	Vertical
5	496.57	24.67	18.81	47.00	22.33	100	54	Vertical
6	870.02	33.10	27.25	47.00	13.90	100	260	Vertical

**RESULT: PASS**

Any report having not been signed by authorized approver, or having been altered without authorization, or having not been stamped by the "Dedicated Testing/Inspection Stamp" is deemed to be invalid. Copying or excerpting portion of, or altering the content of the report is not permitted without the written authorization of AGC. The test results presented in the report apply only to the tested sample. Any objections to report issued by AGC should be submitted to AGC within 15days after the issuance of the test report. Further enquiry of validity or verification of the test report should be addressed to AGC by agc01@agccert.com.

## 11 EN IEC 55015 RADIATED ELECTROMAGNETIC DISTURBANCE TEST

### 11.1 LIMITS OF RADIATED ELECTROMAGNETIC DISTURBANCE IN THE RANGE 9 KHZ TO 30 MHZ

Frequency Range	Limits for Loop Diameter dB(uA) *		
	2m	3m	4m
9 KHz-70 KHz	88 *	81 *	75 *
70 KHz-150 KHz	88 to 58 * *	81 to 51 * *	75 to 45 * *
150 kHz-3.0 MHz	58 to 22 * *	51 to 15 * *	45 to 9 * *
3.0 MHz-30 MHz	22 * * *	15 to 16 * * *	9 to 12 * * *

Note:

\* At the transition frequency, the lower limit applies.

\* \* Decreasing linearly with the logarithm of the frequency. For electrode less lamps and luminaries, the limit in the frequency range of 2.2 MHz to 3.0 MHz is 58 dB(uA) for 2m, 51 dB(uA) for 3m and 45 dB(uA) for 4m loop diameter.

\* \* \* Increasing linearly with the logarithm of the frequency.

Any report having not been signed by authorized approver, or having been altered without authorization, or having not been stamped by the "Dedicated Testing/Inspection Stamp" is deemed to be invalid. Copying or excerpting portion of, or altering the content of the report is not permitted without the written authorization of AGC. The test results presented in the report apply only to the tested sample. Any objections to report issued by AGC should be submitted to AGC within 15days after the issuance of the test report. Further enquiry of validity or verification of the test report should be addressed to AGC by agc01@agccert.com.

Attestation of Global Compliance(Shenzhen)Co., Ltd

Attestation of Global Compliance(Shenzhen)Std & Tech Co., Ltd

Tel: +86-755 2523 4088 E-mail: agc@agccert.com Web: http://www.agccert.com/

### 11.2 BLOCK DIAGRAM OF TEST SETUP

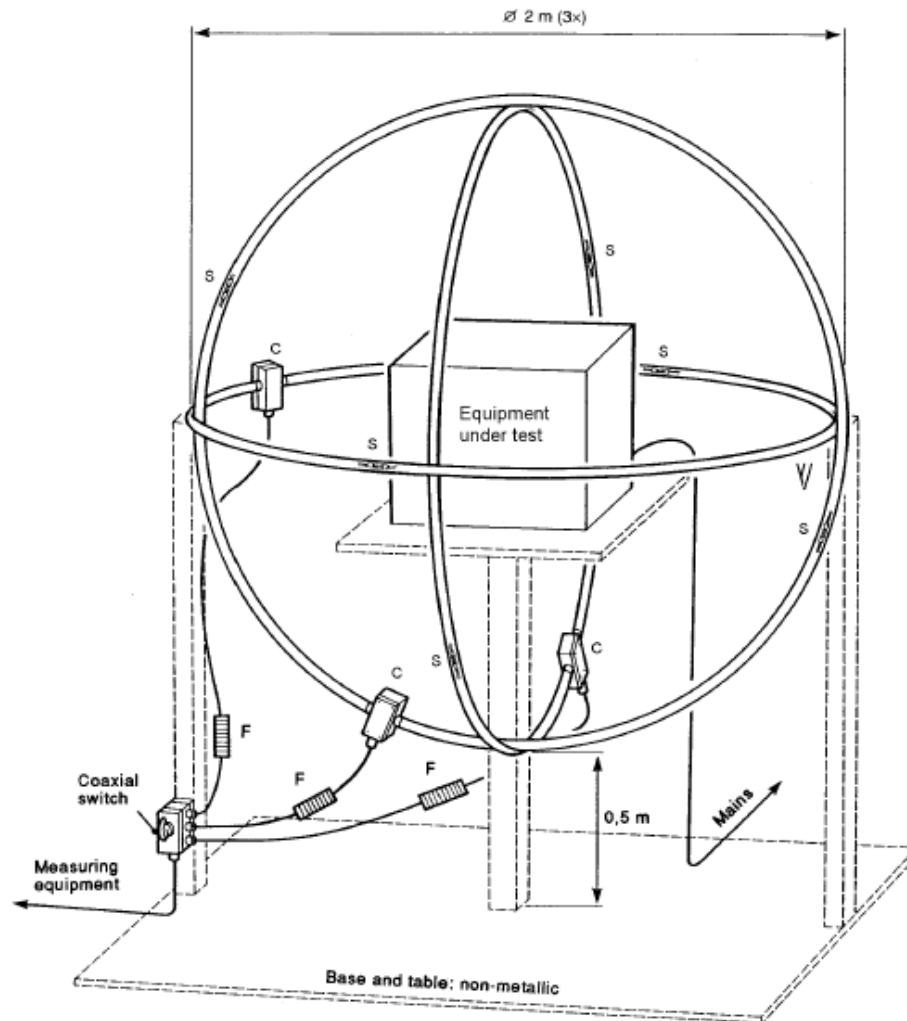

### 11.3 TEST PROCEDURE

The magnetic component shall be measured by means of a loop antenna as described in EN IEC 55015. The lighting equipment shall be placed in the centre of the antenna, and the position is not critical.

The test object was operated at its upper limit of its rated voltage and its rated frequency. The induced current in the loop antenna is measured by means of a current probe(1V/A) and the CISPR measuring receiver. By means of a coaxial switch the three field directions can be measured in sequence. Each value shall fulfill the requirements given.

Any report having not been signed by authorized approver, or having been altered without authorization, or having not been stamped by the "Dedicated Testing/Inspection Stamp" is deemed to be invalid. Copying or excerpting portion of, or altering the content of the report is not permitted without the written authorization of AGC. The test results presented in the report apply only to the tested sample. Any objections to report issued by AGC should be submitted to AGC within 15days after the issuance of the test report. Further enquiry of validity or verification of the test report should be addressed to AGC by agc01@agccert.com.

### 11.4 TEST RESULTS OF RADIATED ELECTROMAGNETIC DISTURBANCE

Mode2

X

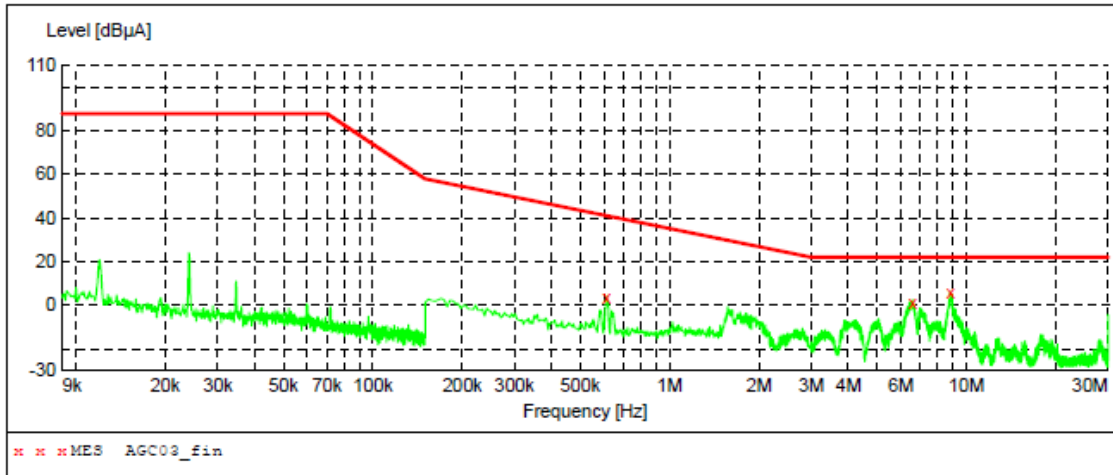

**MEASUREMENT RESULT: "AGC03\_fin"**

Frequency MHz	Level dBµA	Transd dB	Limit dBµA	Margin dB	Det.	Loop	Azimuth deg
0.614000	3.70	-19.7	41	37.4	QP	X	0.00
6.582000	0.70	-21.0	22	21.3	QP	X	0.00
8.838000	5.60	-20.3	22	16.4	QP	X	0.00

Any report having not been signed by authorized approver, or having been altered without authorization, or having not been stamped by the "Dedicated Testing/Inspection Stamp" is deemed to be invalid. Copying or excerpting portion of, or altering the content of the report is not permitted without the written authorization of AGC. The test results presented in the report apply only to the tested sample. Any objections to report issued by AGC should be submitted to AGC within 15days after the issuance of the test report. Further enquiry of validity or verification of the test report should be addressed to AGC by agc01@agccert.com.

Y

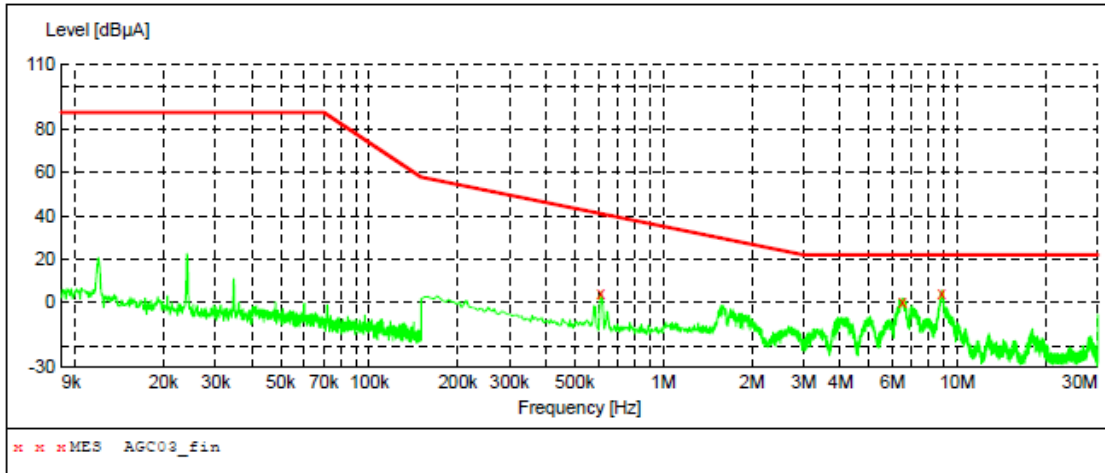

**MEASUREMENT RESULT: "AGC03\_fin"**

Frequency MHz	Level dBµA	Transd dB	Limit dBµA	Margin dB	Det.	Loop	Azimuth deg
0.614000	4.10	-19.7	41	37.0	QP	Y	0.00
6.482000	0.00	-21.0	22	22.0	QP	Y	0.00
8.846000	4.40	-20.3	22	17.6	QP	Y	0.00

Any report having not been signed by authorized approver, or having been altered without authorization, or having not been stamped by the "Dedicated Testing/Inspection Stamp" is deemed to be invalid. Copying or excerpting portion of, or altering the content of the report is not permitted without the written authorization of AGC. The test results presented in the report apply only to the tested sample. Any objections to report issued by AGC should be submitted to AGC within 15days after the issuance of the test report. Further enquiry of validity or verification of the test report should be addressed to AGC by agc01@agccert.com.

Z

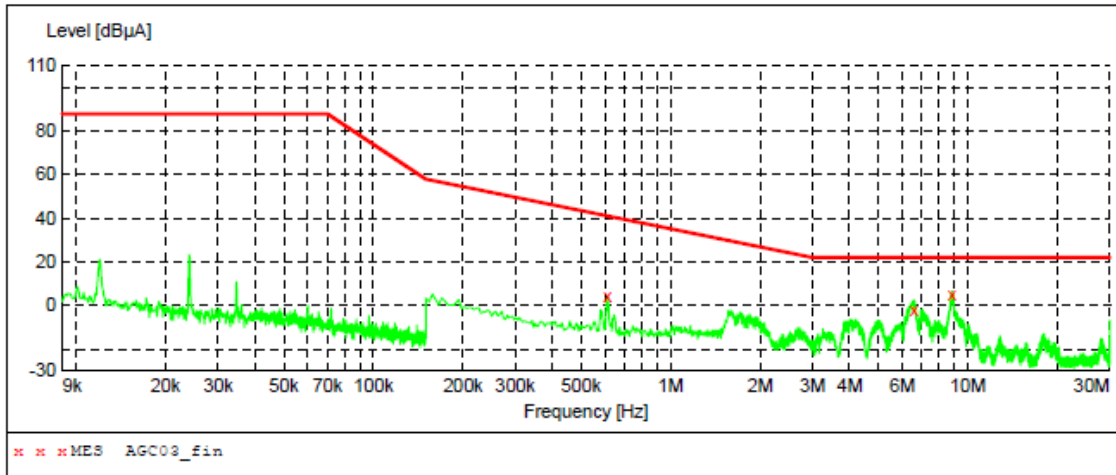

**MEASUREMENT RESULT: "AGC03\_fin"**

Frequency MHz	Level dBµA	Transd dB	Limit dBµA	Margin dB	Det.	Loop	Azimuth deg
0.614000	3.80	-19.7	41	37.3	QP	Z	0.00
6.594000	-1.90	-21.0	22	23.9	QP	Z	0.00
8.830000	4.80	-20.3	22	17.2	QP	Z	0.00

**RESULT: PASS**

Any report having not been signed by authorized approver, or having been altered without authorization, or having not been stamped by the "Dedicated Testing/Inspection Stamp" is deemed to be invalid. Copying or excerpting portion of, or altering the content of the report is not permitted without the written authorization of AGC. The test results presented in the report apply only to the tested sample. Any objections to report issued by AGC should be submitted to AGC within 15days after the issuance of the test report. Further enquiry of validity or verification of the test report should be addressed to AGC by agc01@agccert.com.

## 12 EN IEC 61000-3-2 POWER HARMONICS TEST

### POWER HARMONICS MEASUREMENT

<b>Port</b>	AC mains
<b>Basic Standard</b>	EN IEC 61000-3-2
<b>Limits</b>	CLASS C
<b>Temperature</b>	24.0°C
<b>Humidity</b>	55.0% RH

### 12.1 BLOCK DIAGRAM OF TEST SETUP

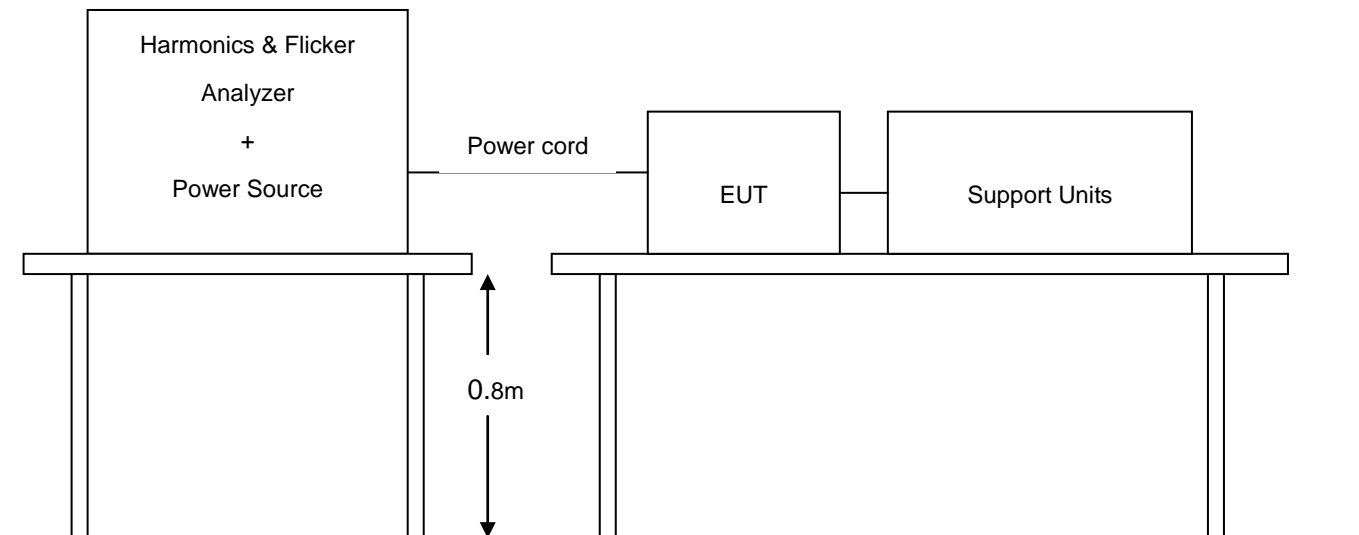

### 12.2 RESULT

Note: Owing to the power of EUT is less than 5W, so test is not applicable.

**13 EN 61000-3-3 VOLTAGE FLUCTUATION / FLICKER TEST**  
**VOLTAGE FLUCTUATION/FLICKER MEASUREMENT**

<b>Port</b>	AC mains
<b>Basic Standard</b>	EN 61000-3-3
<b>Limits</b>	§5 of EN 61000-3-3
<b>Temperature</b>	24.0°C
<b>Humidity</b>	70.0% RH

**13.1 BLOCK DIAGRAM OF TEST SETUP**

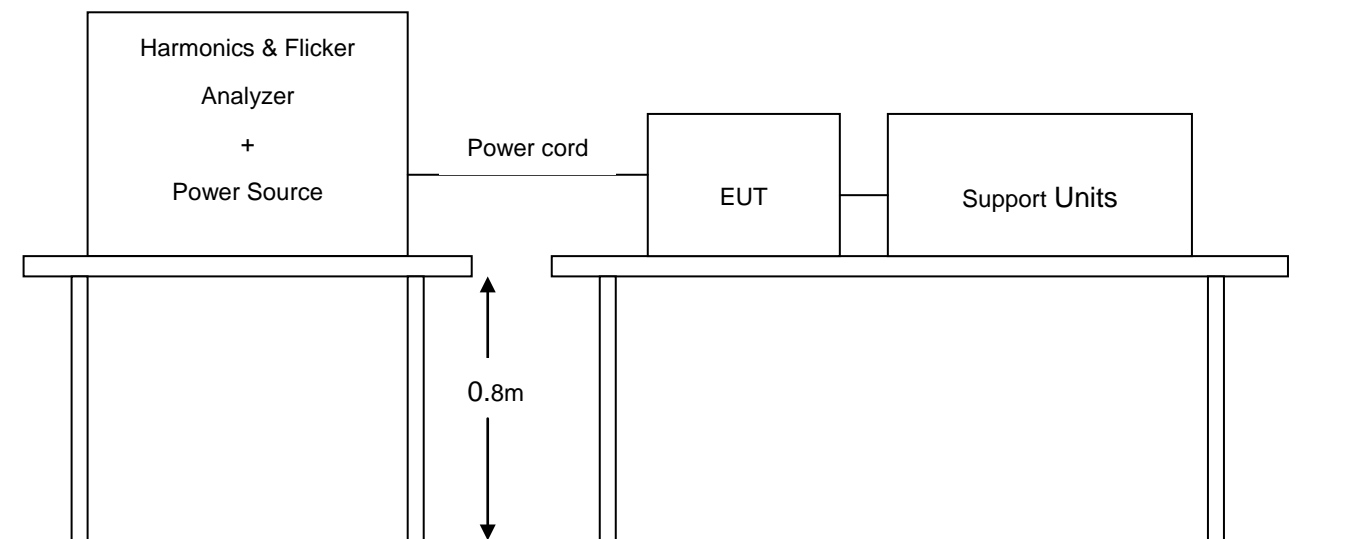

Any report having not been signed by authorized approver, or having been altered without authorization, or having not been stamped by the "Dedicated Testing/Inspection Stamp" is deemed to be invalid. Copying or excerpting portion of, or altering the content of the report is not permitted without the written authorization of AGC. The test results presented in the report apply only to the tested sample. Any objections to report issued by AGC should be submitted to AGC within 15days after the issuance of the test report. Further enquiry of validity or verification of the test report should be addressed to AGC by agc01@agccert.com.

**13.2 RESULT****Flicker Test Summary per EN/EN61000-3-3 (Run time)**

Test Parameter	Measurement Value	Limit	Remarks
Highest dt (%):	0.00	3.30	Pass
Time(mS) > dt:	0.0	500.0	Pass
Highest dc (%):	0.00	3.30	Pass
Highest dmax (%):	0.00	4.00	Pass
Highest Pst (10 min. period):	0.160	1.0	Pass
Highest Plt (2 hr. period):	0.070	0.65	Pass

Any report having not been signed by authorized approver, or having been altered without authorization, or having not been stamped by the "Dedicated Testing/Inspection Stamp" is deemed to be invalid. Copying or excerpting portion of, or altering the content of the report is not permitted without the written authorization of AGC. The test results presented in the report apply only to the tested sample. Any objections to report issued by AGC should be submitted to AGC within 15days after the issuance of the test report. Further enquiry of validity or verification of the test report should be addressed to AGC by [agc01@agccert.com](mailto:agc01@agccert.com).

## 14 EN 61000-4-2 ESD IMMUNITY TEST

### ELECTROSTATIC DISCHARGE (ESD) IMMUNITY TEST

<b>Port</b>	Enclosure
<b>Basic Standard</b>	EN 61000-4-2
<b>Test Level</b>	± 8.0 kV (Air Discharge) ± 4.0 kV (Contact Discharge) ± 4.0 kV (Indirect Discharge)
<b>Standard require</b>	B
<b>Temperature</b>	24.1°C
<b>Humidity</b>	58.2.0 % RH

#### 14.1 BLOCK DIAGRAM OF TEST SETUP

(The 470 k ohm resistors are installed per standard requirement)

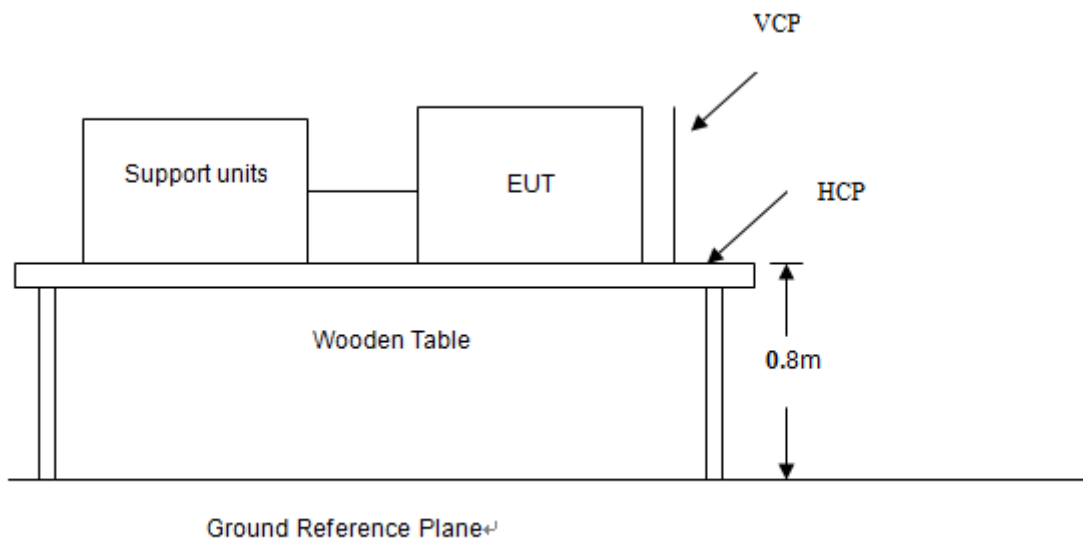

Any report having not been signed by authorized approver, or having been altered without authorization, or having not been stamped by the "Dedicated Testing/Inspection Stamp" is deemed to be invalid. Copying or excerpting portion of, or altering the content of the report is not permitted without the written authorization of AGC. The test results presented in the report apply only to the tested sample. Any objections to report issued by AGC should be submitted to AGC within 15days after the issuance of the test report. Further enquiry of validity or verification of the test report should be addressed to AGC by agc01@agccert.com.

## 14.2 TEST PROCEDURE

The EUT was located 0.1 m minimum from all side of the HCP.

The support units were located 1 m minimum away from the EUT.

EUT worked with resistance load, and make sure EUT worked normally.

Activates the communication function if the EUT with such port(s).

As per the requirement of EN 61547: Contact discharge is the preferred test method, twenty discharges (10 with positive and 10 with negative polarity) shall be applied on each accessible metallic part of the enclosure, terminals are excluded. Air discharges shall be used where contact discharges cannot be applied. Discharges shall be applied on the horizontal or vertical coupling planes as specified in EN 61000-4-2.

The following test condition was followed during the tests.

**Note:** As per the A2 to EN 61000-4-2, a bleed resistor cable is connected between the EUT and HCP during the test.

The electrostatic discharges were applied as follows:

Voltage	Coupling	Test Performance	Result
±4kV	Contact Discharge	No function loss	A
±4kV	Indirect Discharge HCP (Front)	No function loss	A
±4kV	Indirect Discharge HCP (Left)	No function loss	A
±4kV	Indirect Discharge HCP (Right)	No function loss	A
±4kV	Indirect Discharge HCP (Back)	No function loss	A
±4kV	Indirect Discharge VCP (Front)	No function loss	A
±4kV	Indirect Discharge VCP (Left)	No function loss	A
±4kV	Indirect Discharge VCP (Back)	No function loss	A
±4kV	Indirect Discharge VCP (Right)	No function loss	A
±8kV	Air Discharge	No function loss	A

### 14.3 PERFORMANCE & RESULT

<b>Criteria A:</b>	The apparatus continues to operate as intended. No degradation of performance or loss of function is allowed below a performance level specified by the manufacturer, when the apparatus is used as intended. In some cases the performance level may be replaced by a permissible loss of performance.
<b>Criteria B:</b>	The apparatus continues to operate as intended after the test. No degradation of performance or loss of function is allowed below a performance level specified by the manufacturer, when the apparatus is used as intended. In some cases the performance level may be replaced by a permissible loss of performance. During the test, degradation of performance is however allowed.
<b>Criteria C:</b>	Temporary loss of function is allowed, provided the functions self recoverable or can be restored by the operation of controls.

<input checked="" type="checkbox"/> <b>PASS</b> <input type="checkbox"/> <b>FAIL</b>
--

Any report having not been signed by authorized approver, or having been altered without authorization, or having not been stamped by the "Dedicated Testing/Inspection Stamp" is deemed to be invalid. Copying or excerpting portion of, or altering the content of the report is not permitted without the written authorization of AGC. The test results presented in the report apply only to the tested sample. Any objections to report issued by AGC should be submitted to AGC within 15days after the issuance of the test report. Further enquiry of validity or verification of the test report should be addressed to AGC by agc01@agccert.com.

### 15 EN 61000-4-3 RS IMMUNITY TEST

#### RADIATED ELECTROMAGNETIC FIELD IMMUNITY TEST

<b>Port</b>	Enclosure
<b>Basic Standard</b>	EN 61000-4-3
<b>Test Level:</b>	3V/m with 80% AM. 1kHz Modulation.
<b>Standard require</b>	A
<b>Temperature</b>	23.9°C
<b>Humidity</b>	57.3% RH

#### 15.1 BLOCK DIAGRAM OF TEST SETUP

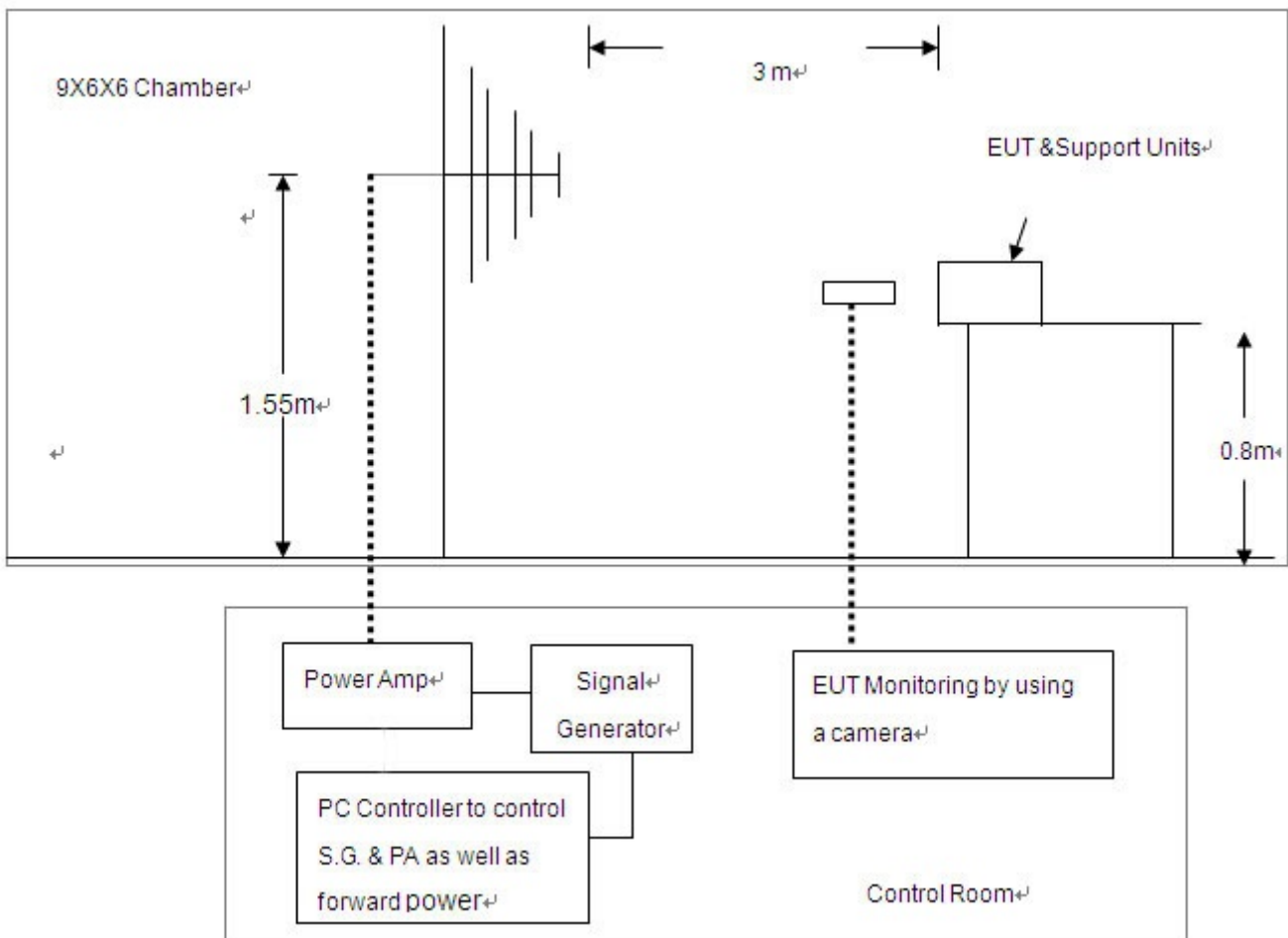

Any report having not been signed by authorized approver, or having been altered without authorization, or having not been stamped by the "Dedicated Testing/Inspection Stamp" is deemed to be invalid. Copying or excerpting portion of, or altering the content of the report is not permitted without the written authorization of AGC. The test results presented in the report apply only to the tested sample. Any objections to report issued by AGC should be submitted to AGC within 15days after the issuance of the test report. Further enquiry of validity or verification of the test report should be addressed to AGC by agc01@agccert.com.

## 15.2 TEST PROCEDURE

The EUT was located at the edge of supporting table keep 3 meter away from transmitting antenna, it just the calibrated square area of field uniformity. The support units were located outside of the uniformity area, but the cable(s) connected with EUT were exposed to the calibrated field as per EN 61000-4-3.

EUT worked with resistance load, and make sure EUT worked normally.

Setting the testing parameters of RS test software per EN 61000-4-3.

Performing the test at each side of with specified level (3V/m) at 1% steps and test frequency from 80MHz to 1000MHz.

Recording the test result in following table.

### EN 61000-4-3 Final test conditions:

Test level: 3V/m

Steps: 1 % of fundamental

Dwell Time: 1 sec

Range (MHz)	Field	Modulation	Polarity	Position	Test Performance	Result
80-1000	3V/m	AM	H	Front	No function loss	A
80-1000	3V/m	AM	H	Left	No function loss	A
80-1000	3V/m	AM	H	Back	No function loss	A
80-1000	3V/m	AM	H	Right	No function loss	A
80-1000	3V/m	AM	V	Front	No function loss	A
80-1000	3V/m	AM	V	Left	No function loss	A
80-1000	3V/m	AM	V	Back	No function loss	A
80-1000	3V/m	AM	V	Right	No function loss	A

Any report having not been signed by authorized approver, or having been altered without authorization, or having not been stamped by the "Dedicated Testing/Inspection Stamp" is deemed to be invalid. Copying or excerpting portion of, or altering the content of the report is not permitted without the written authorization of AGC. The test results presented in the report apply only to the tested sample. Any objections to report issued by AGC should be submitted to AGC within 15days after the issuance of the test report. Further enquiry of validity or verification of the test report should be addressed to AGC by [agc01@agccert.com](mailto:agc01@agccert.com).

Attestation of Global Compliance(Shenzhen)Co., Ltd

Attestation of Global Compliance(Shenzhen)Std & Tech Co., Ltd

Tel: +86-755 2523 4088 E-mail: [agc@agccert.com](mailto:agc@agccert.com) Web: <http://www.agccert.com/>

### 15.3 PERFORMANCE & RESULT

<b>Criteria A:</b>	The apparatus continues to operate as intended. No degradation of performance or loss of function is allowed below a performance level specified by the manufacturer, when the apparatus is used as intended. In some cases the performance level may be replaced by a permissible loss of performance.
<b>Criteria B:</b>	The apparatus continues to operate as intended after the test. No degradation of performance or loss of function is allowed below a performance level specified by the manufacturer, when the apparatus is used as intended. In some cases the performance level may be replaced by a permissible loss of performance. During the test, degradation of performance is however allowed.
<b>Criteria C:</b>	Temporary loss of function is allowed, provided the functions self recoverable or can be restored by the operation of controls.

<input checked="" type="checkbox"/> <b>PASS</b>	<input type="checkbox"/> <b>FAIL</b>
---	--------------------------------------

Any report having not been signed by authorized approver, or having been altered without authorization, or having not been stamped by the "Dedicated Testing/Inspection Stamp" is deemed to be invalid. Copying or excerpting portion of, or altering the content of the report is not permitted without the written authorization of AGC. The test results presented in the report apply only to the tested sample. Any objections to report issued by AGC should be submitted to AGC within 15days after the issuance of the test report. Further enquiry of validity or verification of the test report should be addressed to AGC by agc01@agccert.com.

## 16 EN 61000-4-4 EFT IMMUNITY TEST

### ELECTRICAL FAST TRANSIENTS/BURST IMMUNITY TEST

<b>Port</b>	On Power Supply Lines
<b>Basic Standard</b>	EN 61000-4-4
<b>Test Level</b>	+/- 1kV for Power Supply Lines
<b>Standard require</b>	B
<b>Temperature</b>	23.8°C
<b>Humidity</b>	58.6% RH

### 16.1 BLOCK DIAGRAM OF TEST SETUP

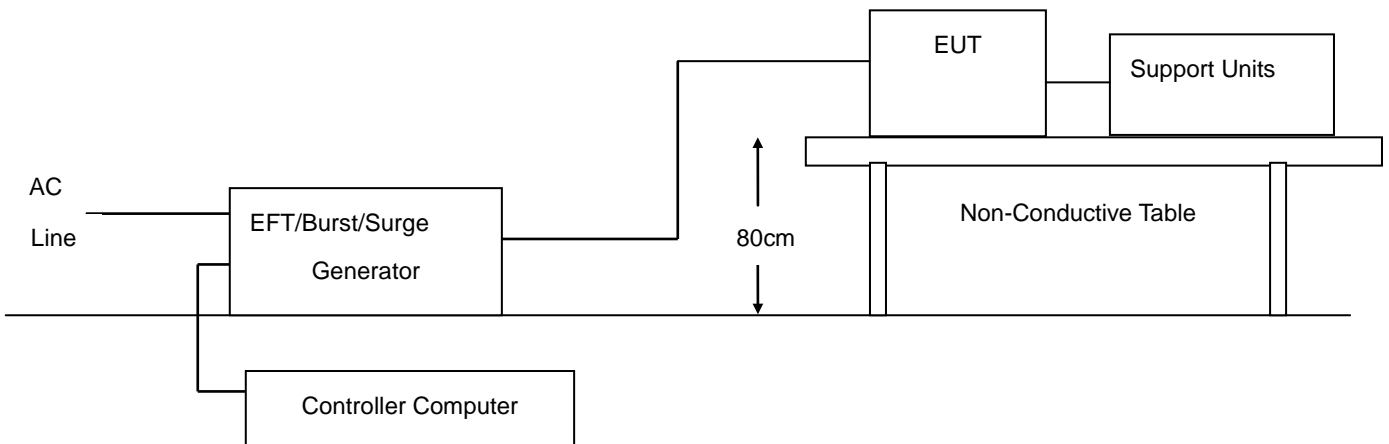

Any report having not been signed by authorized approver, or having been altered without authorization, or having not been stamped by the "Dedicated Testing/Inspection Stamp" is deemed to be invalid. Copying or excerpting portion of, or altering the content of the report is not permitted without the written authorization of AGC. The test results presented in the report apply only to the tested sample. Any objections to report issued by AGC should be submitted to AGC within 15days after the issuance of the test report. Further enquiry of validity or verification of the test report should be addressed to AGC by [agc01@agccert.com](mailto:agc01@agccert.com).

## 16.2 TEST PROCEDURE

The EUT and support units were located on a wooden table 0.1m away from ground reference plane.  
A 1.0 meter long power cord was attached to EUT during the test.  
The length of communication cable between communication port and clamp was keeping within 1 meter.  
EUT worked with resistance load, and make sure EUT worked normally.  
Related peripherals work during the test.  
Recording the test result as shown in following table.

### Test conditions:

Impulse Frequency: 5 kHz

Tr/Th: 5/50ns

Burst Duration: 15ms

Burst Period: 300ms

Inject Line	Voltage kV	Inject Method	Test Performance	Result
L+N	+/- 1	direct	No function loss	A

## 16.3 PERFORMANCE & RESULT

<b>Criteria A:</b>	The apparatus continues to operate as intended. No degradation of performance or loss of function is allowed below a performance level specified by the manufacturer, when the apparatus is used as intended. In some cases the performance level may be replaced by a permissible loss of performance.
<b>Criteria B:</b>	The apparatus continues to operate as intended after the test. No degradation of performance or loss of function is allowed below a performance level specified by the manufacturer, when the apparatus is used as intended. In some cases the performance level may be replaced by a permissible loss of performance. During the test, degradation of performance is however allowed.
<b>Criteria C:</b>	Temporary loss of function is allowed, provided the functions self recoverable or can be restored by the operation of controls.

<input checked="" type="checkbox"/> <b>PASS</b> <input type="checkbox"/> <b>FAIL</b>
--

Any report having not been signed by authorized approver, or having been altered without authorization, or having not been stamped by the "Dedicated Testing/Inspection Stamp" is deemed to be invalid. Copying or excerpting portion of, or altering the content of the report is not permitted without the written authorization of AGC. The test results presented in the report apply only to the tested sample. Any objections to report issued by AGC should be submitted to AGC within 15days after the issuance of the test report. Further enquiry of validity or verification of the test report should be addressed to AGC by agc01@agccert.com.

## 17 EN 61000-4-5 SURGE IMMUNITY TEST

### SURGE IMMUNITY TEST

<b>Port</b>	On Power Supply Lines
<b>Basic Standard</b>	EN 61000-4-5
<b>Requirements</b>	+/-0.5kV (Line to Line) (Applicable for power less than the 25W)
<b>Standard require</b>	B
<b>Temperature</b>	23.8°C
<b>Humidity</b>	58.6% RH

### 17.1 BLOCK DIAGRAM OF TEST SETUP

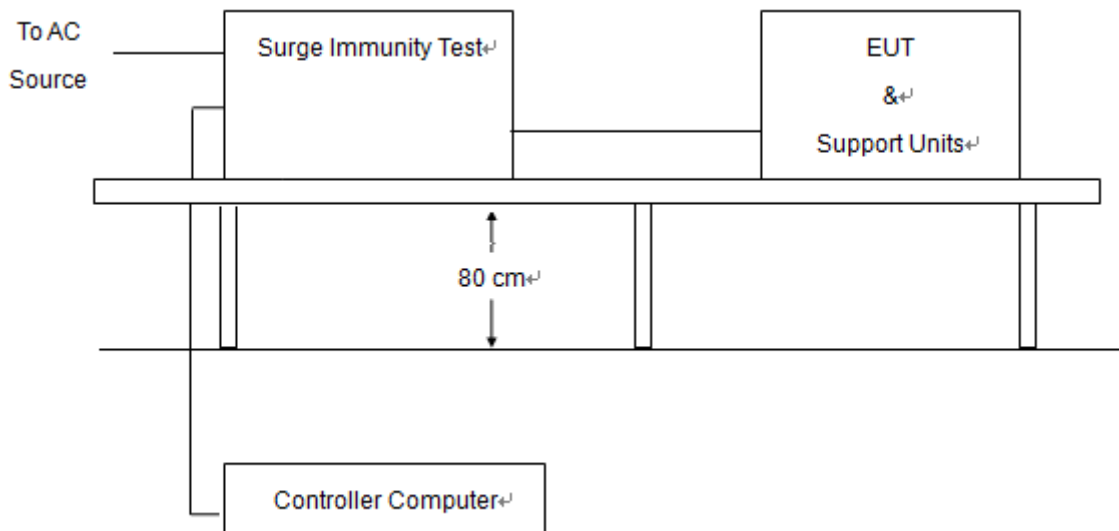

Any report having not been signed by authorized approver, or having been altered without authorization, or having not been stamped by the "Dedicated Testing/Inspection Stamp" is deemed to be invalid. Copying or excerpting portion of, or altering the content of the report is not permitted without the written authorization of AGC. The test results presented in the report apply only to the tested sample. Any objections to report issued by AGC should be submitted to AGC within 15days after the issuance of the test report. Further enquiry of validity or verification of the test report should be addressed to AGC by agc01@agccert.com.

### 17.2 TEST PROCEDURE

The EUT and support units were located on a wooden table 0.8 m away from ground floor.

EUT worked with resistance load, and make sure EUT worked normally.

Recording the test result as shown in following table.

**Test conditions:**

<b>Voltage Waveform</b>	1.2/50 <i>us</i>
<b>Current Waveform</b>	8/20 <i>us</i>
<b>Polarity</b>	Positive/Negative
<b>Phase angle</b>	90°, 270°
<b>Number of Test</b>	5

Coupling Line	Voltage (kV)	Polarity	Coupling Method	Test Performance	Result
L1-N	0.5	Positive	Capacitive	No function loss	A
L1-N	0.5	Negative	Capacitive	No function loss	A

### 17.3 PERFORMANCE & RESULT

<b>Criteria A:</b>	The apparatus continues to operate as intended. No degradation of performance or loss of function is allowed below a performance level specified by the manufacturer, when the apparatus is used as intended. In some cases the performance level may be replaced by a permissible loss of performance.
<b>Criteria B:</b>	The apparatus continues to operate as intended after the test. No degradation of performance or loss of function is allowed below a performance level specified by the manufacturer, when the apparatus is used as intended. In some cases the performance level may be replaced by a permissible loss of performance. During the test, degradation of performance is however allowed.
<b>Criteria C:</b>	Temporary loss of function is allowed, provided the functions self recoverable or can be restored by the operation of controls.

<input checked="" type="checkbox"/> <b>PASS</b> <input type="checkbox"/> <b>FAIL</b>
--

Any report having not been signed by authorized approver, or having been altered without authorization, or having not been stamped by the "Dedicated Testing/Inspection Stamp" is deemed to be invalid. Copying or excerpting portion of, or altering the content of the report is not permitted without the written authorization of AGC. The test results presented in the report apply only to the tested sample. Any objections to report issued by AGC should be submitted to AGC within 15days after the issuance of the test report. Further enquiry of validity or verification of the test report should be addressed to AGC by agc01@agccert.com.

### 18 EN 61000-4-6 CS IMMUNITY TEST

<b>Port</b>	On Power Supply Lines
<b>Basic Standard</b>	EN 61000-4-6
<b>Requirements</b>	3V with 80% AM. 1 kHz Modulation
<b>Standard require</b>	A
<b>Temperature</b>	23.5°C
<b>Humidity</b>	57.5.0% RH

#### 18.1 BLOCK DIAGRAM OF TEST SETUP

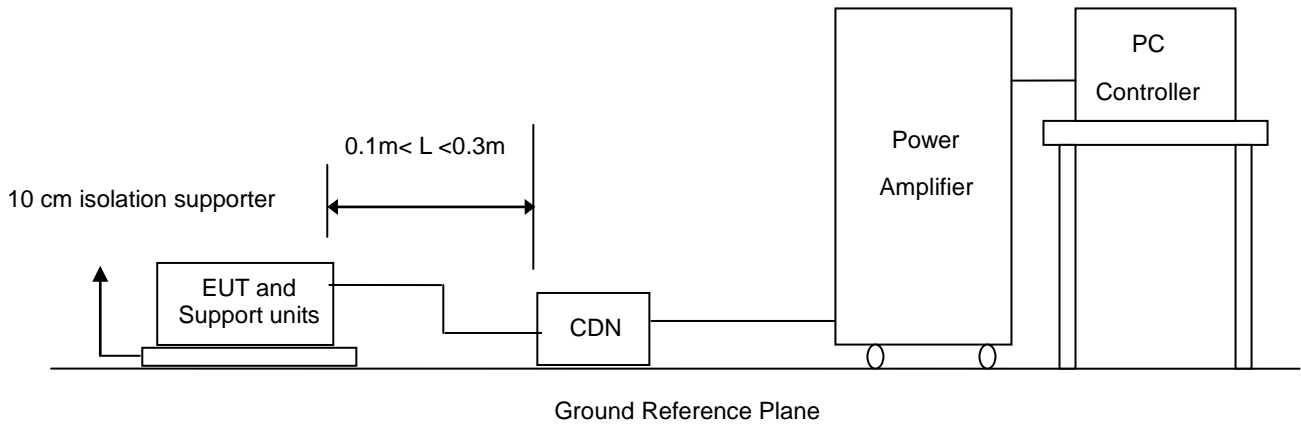

Any report having not been signed by authorized approver, or having been altered without authorization, or having not been stamped by the "Dedicated Testing/Inspection Stamp" is deemed to be invalid. Copying or excerpting portion of, or altering the content of the report is not permitted without the written authorization of AGC. The test results presented in the report apply only to the tested sample. Any objections to report issued by AGC should be submitted to AGC within 15days after the issuance of the test report. Further enquiry of validity or verification of the test report should be addressed to AGC by agc01@agccert.com.

## 18.2 TEST PROCEDURE

The EUT and support units were located at a ground reference plane with the interposition of a 0.1 m thickness insulating support and the CDN was located on GRP directly.

EUT worked with resistance load, and make sure EUT worked normally.

Related peripherals work during the test.

Setting the testing parameters of CS test software per EN 61000-4-6.

Recording the test result in following table.

### Test conditions:

<b>Frequency Range</b>	0.15MHz-80MHz
<b>Frequency Step</b>	1% of fundamental
<b>Dwell Time</b>	1 sec

Range (MHz)	Strength	Modulation	Test Performance	Result
0.15-80	3V	AM	No function loss	A

## 18.3 PERFORMANCE & RESULT

<b>Criteria A:</b>	The apparatus continues to operate as intended. No degradation of performance or loss of function is allowed below a performance level specified by the manufacturer, when the apparatus is used as intended. In some cases the performance level may be replaced by a permissible loss of performance.
<b>Criteria B:</b>	The apparatus continues to operate as intended after the test. No degradation of performance or loss of function is allowed below a performance level specified by the manufacturer, when the apparatus is used as intended. In some cases the performance level may be replaced by a permissible loss of performance. During the test, degradation of performance is however allowed.
<b>Criteria C:</b>	Temporary loss of function is allowed, provided the functions self recoverable or can be restored by the operation of controls.

<input checked="" type="checkbox"/> <b>PASS</b> <input type="checkbox"/> <b>FAIL</b>
--

Any report having not been signed by authorized approver, or having been altered without authorization, or having not been stamped by the "Dedicated Testing/Inspection Stamp" is deemed to be invalid. Copying or excerpting portion of, or altering the content of the report is not permitted without the written authorization of AGC. The test results presented in the report apply only to the tested sample. Any objections to report issued by AGC should be submitted to AGC within 15days after the issuance of the test report. Further enquiry of validity or verification of the test report should be addressed to AGC by agc01@agccert.com.

Attestation of Global Compliance(Shenzhen)Co., Ltd

Attestation of Global Compliance(Shenzhen)Std & Tech Co., Ltd

Tel: +86-755 2523 4088 E-mail: agc@agccert.com Web: http://www.agccert.com/

**19 EN 61000-4-8 PFMF TEST**

**POWER FREQUENCY MAGNETIC FIELDS IMMUNITY TEST**

<b>Port</b>	Enclosure
<b>Basic Standard</b>	EN 61000-4-8
<b>Requirements</b>	50/60 Hz, 3A/m
<b>Standard require</b>	A
<b>Temperature</b>	22.6°C
<b>Humidity</b>	58.7% RH

**19.1 BLOCK DIAGRAM OF TEST SETUP**

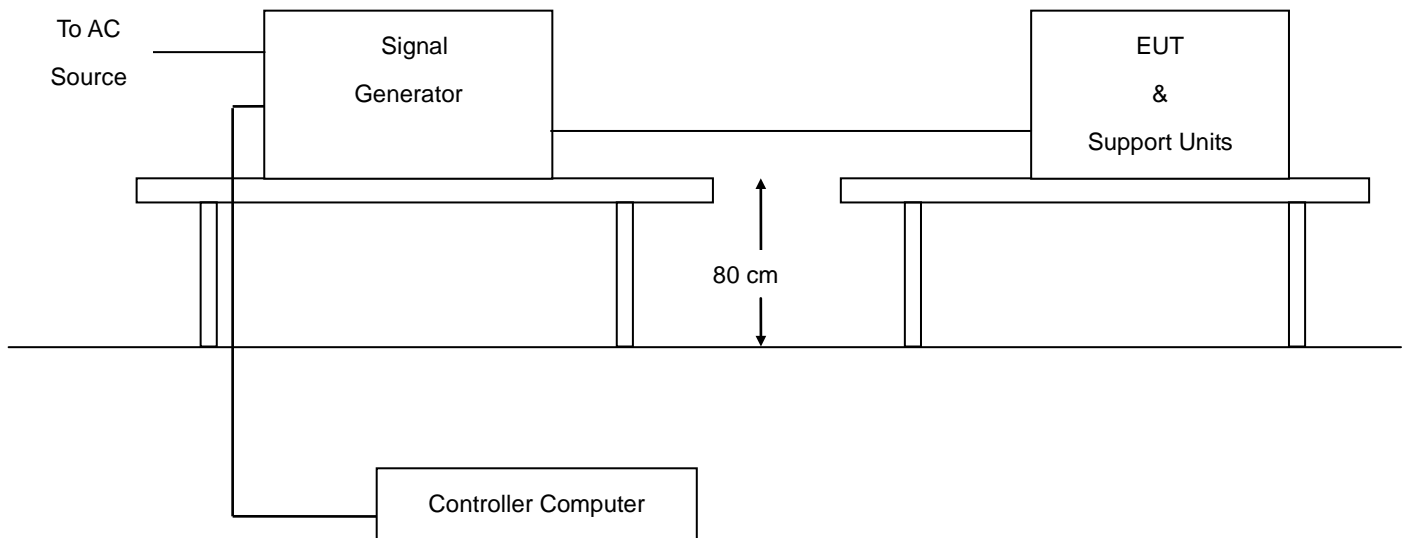

Any report having not been signed by authorized approver, or having been altered without authorization, or having not been stamped by the "Dedicated Testing/Inspection Stamp" is deemed to be invalid. Copying or excerpting portion of, or altering the content of the report is not permitted without the written authorization of AGC. The test results presented in the report apply only to the tested sample. Any objections to report issued by AGC should be submitted to AGC within 15days after the issuance of the test report. Further enquiry of validity or verification of the test report should be addressed to AGC by agc01@agccert.com.

## 19.2 TEST PROCEDURE

The EUT shall be subjected to the test magnetic field by using the induction coil of standard dimensions (1m x 1m). The induction coil shall then be rotated by 90° in order to expose the EUT to the test field with different orientations.

### Test Conditions:

Frequency	Polarity	Level	Test Performance	Performance Result
50 Hz	X	3 A/m	No function loss	A
50 Hz	Y	3 A/m	No function loss	A
50 Hz	Z	3 A/m	No function loss	A

## 19.3 PERFORMANCE & RESULT

<b>Criteria A:</b>	The apparatus continues to operate as intended. No degradation of performance or loss of function is allowed below a performance level specified by the manufacturer, when the apparatus is used as intended. In some cases the performance level may be replaced by a permissible loss of performance.
<b>Criteria B:</b>	The apparatus continues to operate as intended after the test. No degradation of performance or loss of function is allowed below a performance level specified by the manufacturer, when the apparatus is used as intended. In some cases the performance level may be replaced by a permissible loss of performance. During the test, degradation of performance is however allowed.
<b>Criteria C:</b>	Temporary loss of function is allowed, provided the functions self recoverable or can be restored by the operation of controls.

<input checked="" type="checkbox"/> <b>PASS</b> <input type="checkbox"/> <b>FAIL</b>
--

Any report having not been signed by authorized approver, or having been altered without authorization, or having not been stamped by the "Dedicated Testing/Inspection Stamp" is deemed to be invalid. Copying or excerpting portion of, or altering the content of the report is not permitted without the written authorization of AGC. The test results presented in the report apply only to the tested sample. Any objections to report issued by AGC should be submitted to AGC within 15days after the issuance of the test report. Further enquiry of validity or verification of the test report should be addressed to AGC by agc01@agccert.com.

## 20 EN 61000-4-11 DIPS IMMUNITY TEST

### VOLTAGE DIPS, SHORT INTERRUPTIONS AND VOLTAGE VARIATIONS IMMUNITY TEST

<b>Port</b>	On Power Supply Lines
<b>Basic Standard</b>	EN 61000-4-11
<b>Requirements</b>	PHASE ANGLE 0, 45, 90, 135, 180, 225, 270, 315 degrees
<b>Test Interval</b>	Min. 10 sec.
<b>Temperature</b>	23.8°C
<b>Humidity</b>	58.6% RH

### 20.1 BLOCK DIAGRAM OF TEST SETUP

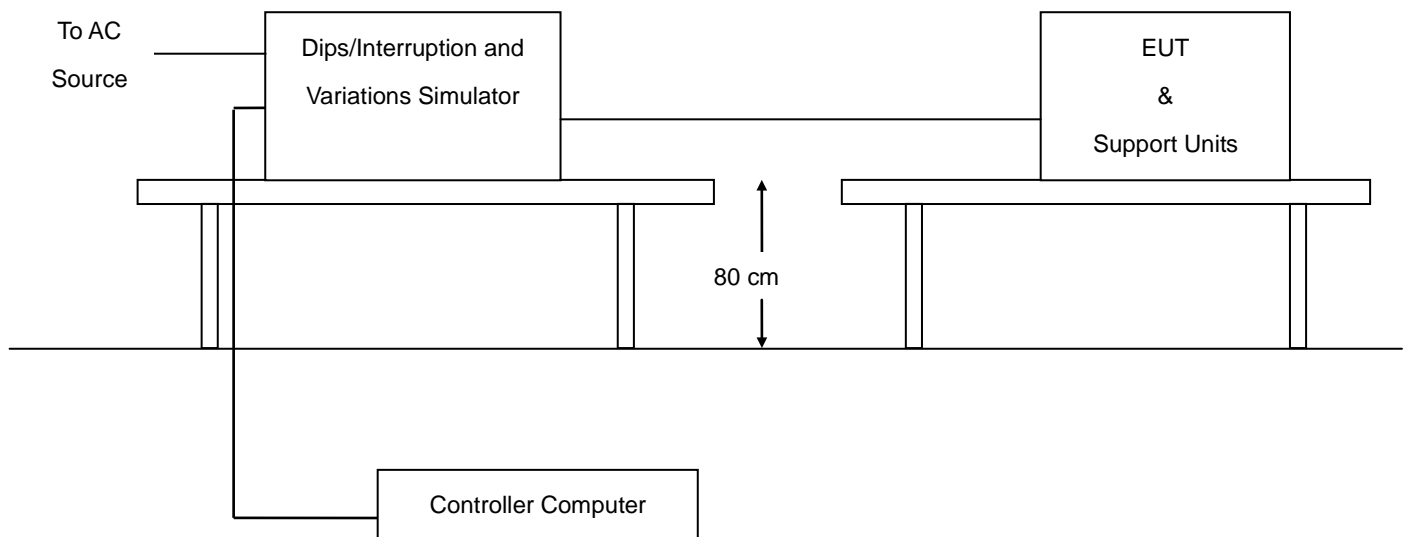

Any report having not been signed by authorized approver, or having been altered without authorization, or having not been stamped by the "Dedicated Testing/Inspection Stamp" is deemed to be invalid. Copying or excerpting portion of, or altering the content of the report is not permitted without the written authorization of AGC. The test results presented in the report apply only to the tested sample. Any objections to report issued by AGC should be submitted to AGC within 15days after the issuance of the test report. Further enquiry of validity or verification of the test report should be addressed to AGC by [agc01@agccert.com](mailto:agc01@agccert.com).

## 20.2 TEST PROCEDURE

The EUT and support units were located on a wooden table, 0.1 m away from ground floor.  
EUT worked with resistance load, and make sure EUT worked normally.  
Setting the parameter of tests and then perform the test software of test simulator.  
Conditions changes to occur at 0 degree crossover point of the voltage waveform.  
Recording the test result in test record form.

### Test conditions:

The duration with a sequence of three dips/interruptions with interval of 10 s minimum  
(Between each test event)

### Voltage Dips and Interruptions:

Test Level % U <sub>T</sub>	Reduction (%)	Duration ( periods)	Observation	Performance Result
0	100	0.5	Normal	A
70	30	10	Normal	A

## 20.3 INTERPRETATION

<b>Criteria A:</b>	The apparatus continues to operate as intended. No degradation of performance or loss of function is allowed below a performance level specified by the manufacturer, when the apparatus is used as intended. In some cases the performance level may be replaced by a permissible loss of performance.
<b>Criteria B:</b>	The apparatus continues to operate as intended after the test. No degradation of performance or loss of function is allowed below a performance level specified by the manufacturer, when the apparatus is used as intended. In some cases the performance level may be replaced by a permissible loss of performance. During the test, degradation of performance is however allowed.
<b>Criteria C:</b>	Temporary loss of function is allowed, provided the functions self recoverable or can be restored by the operation of controls.

<input checked="" type="checkbox"/> <b>PASS</b> <input type="checkbox"/> <b>FAIL</b>
--

Any report having not been signed by authorized approver, or having been altered without authorization, or having not been stamped by the "Dedicated Testing/Inspection Stamp" is deemed to be invalid. Copying or excerpting portion of, or altering the content of the report is not permitted without the written authorization of AGC. The test results presented in the report apply only to the tested sample. Any objections to report issued by AGC should be submitted to AGC within 15days after the issuance of the test report. Further enquiry of validity or verification of the test report should be addressed to AGC by agc01@agccert.com.

**APPENDIX A: PHOTOGRAPHS OF TEST SETUP**  
**EN IEC 55015 CONDUCTED EMISSION TEST SETUP**



**EN IEC 55015 RADIATED EMISSION TEST SETUP**

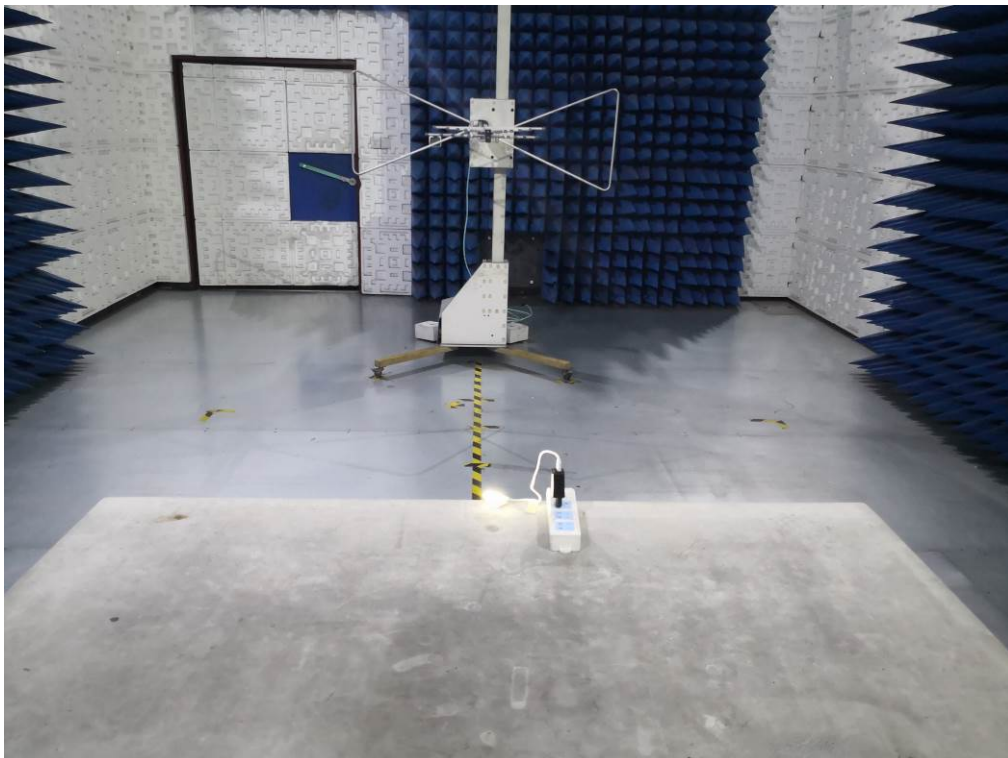

Any report having not been signed by authorized approver, or having been altered without authorization, or having not been stamped by the “Dedicated Testing/Inspection Stamp” is deemed to be invalid. Copying or excerpting portion of, or altering the content of the report is not permitted without the written authorization of AGC. The test results presented in the report apply only to the tested sample. Any objections to report issued by AGC should be submitted to AGC within 15days after the issuance of the test report. Further enquiry of validity or verification of the test report should be addressed to AGC by [agc01@agccert.com](mailto:agc01@agccert.com).

### EN IEC 55015 RADIATED ELECTROMAGNETIC DISTURBANCE TEST



### EN 61000-3-3 VOLTAGE FLUCTUATION / FLICKER TEST

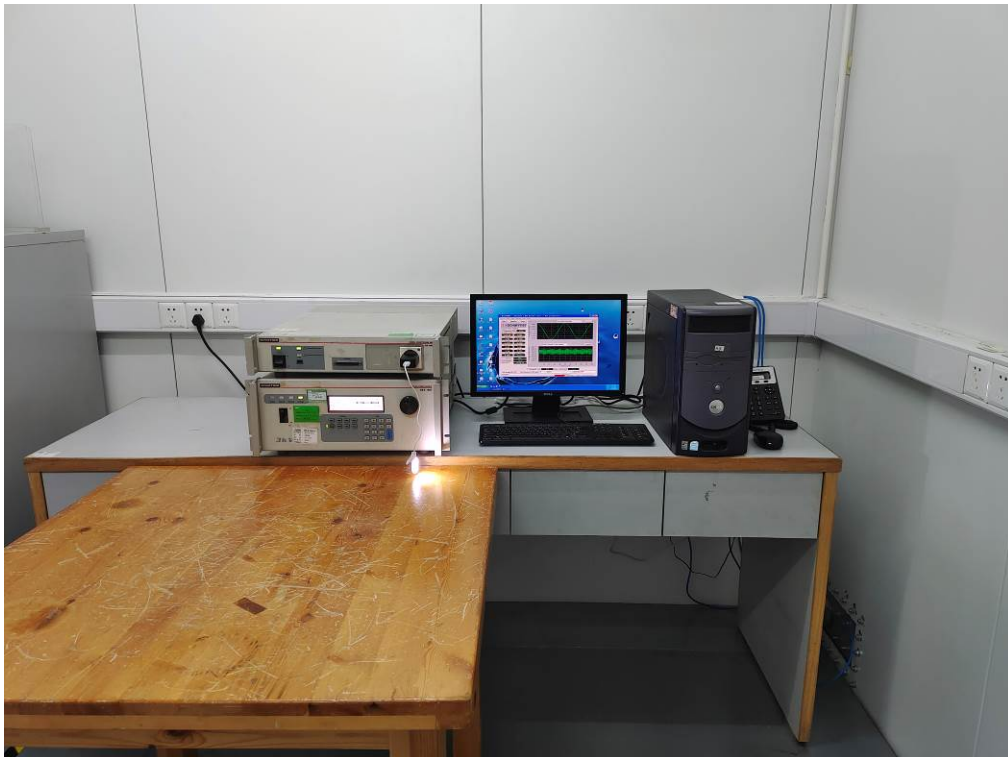

Any report having not been signed by authorized approver, or having been altered without authorization, or having not been stamped by the “Dedicated Testing/Inspection Stamp” is deemed to be invalid. Copying or excerpting portion of, or altering the content of the report is not permitted without the written authorization of AGC. The test results presented in the report apply only to the tested sample. Any objections to report issued by AGC should be submitted to AGC within 15days after the issuance of the test report. Further enquiry of validity or verification of the test report should be addressed to AGC by [agc01@agccert.com](mailto:agc01@agccert.com).

### EN 61000-4-2 ESD IMMUNITY TEST SETUP

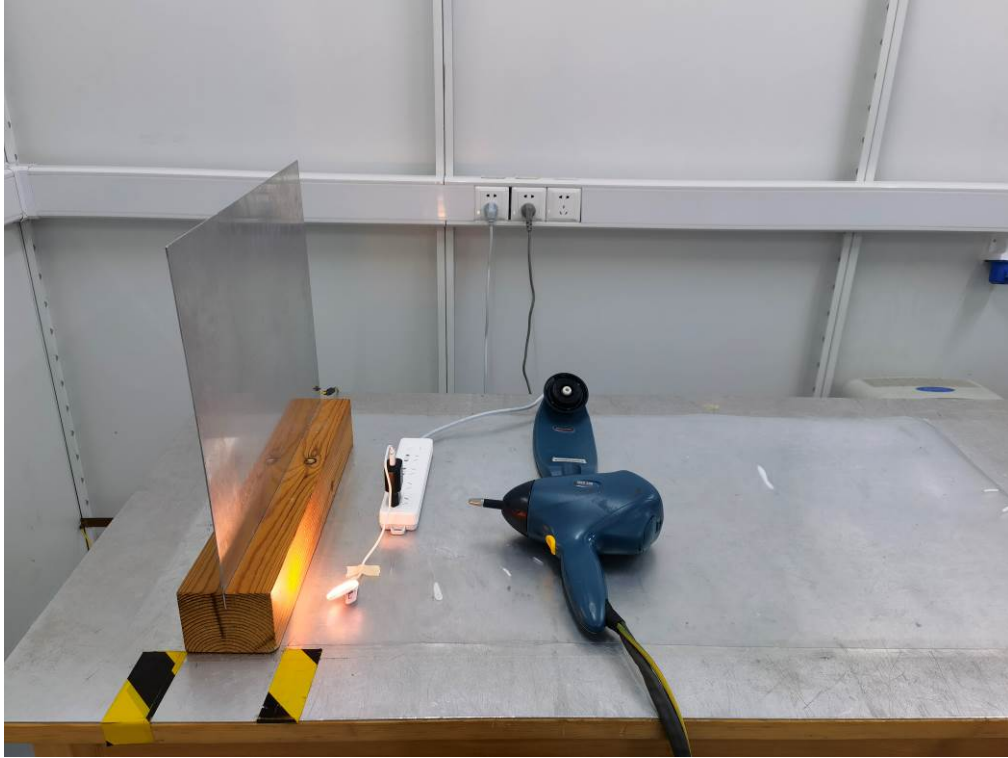

### EN 61000-4-3 RS IMMUNITY TEST SETUP

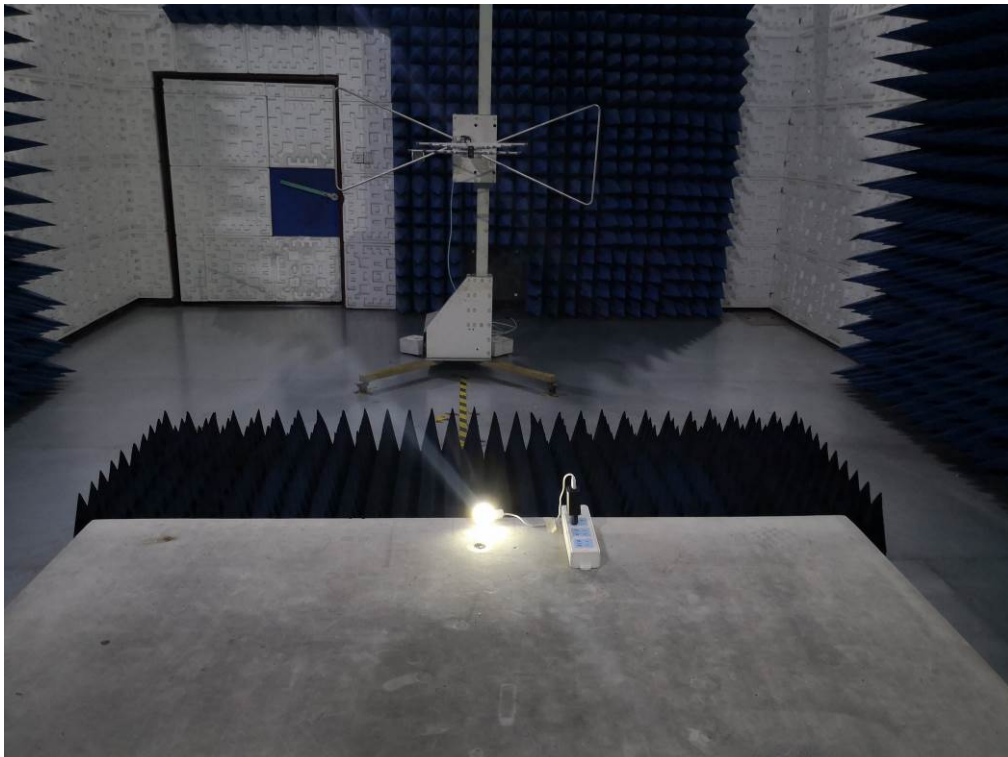

Any report having not been signed by authorized approver, or having been altered without authorization, or having not been stamped by the “Dedicated Testing/Inspection Stamp” is deemed to be invalid. Copying or excerpting portion of, or altering the content of the report is not permitted without the written authorization of AGC. The test results presented in the report apply only to the tested sample. Any objections to report issued by AGC should be submitted to AGC within 15days after the issuance of the test report. Further enquiry of validity or verification of the test report should be addressed to AGC by [agc01@agccert.com](mailto:agc01@agccert.com).

EN 61000-4-4/-5/-11 EFT SURGE AND DIPS IMMUNITY TEST SETUP



EN 61000-4-6 CS Immunity Test Setup

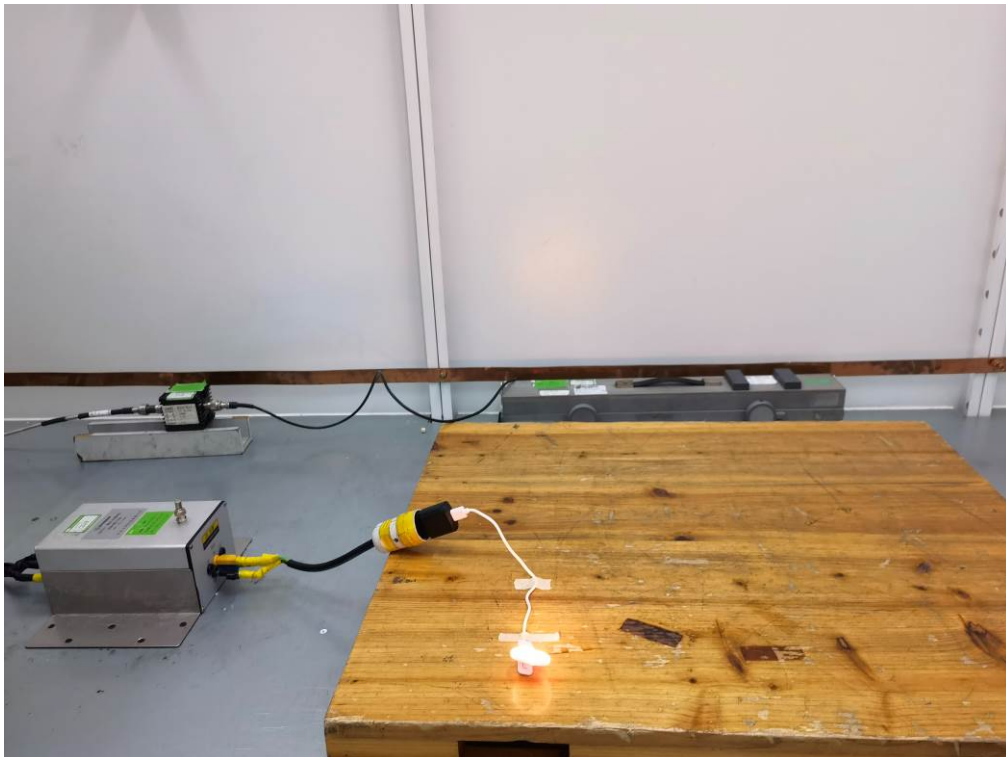

Any report having not been signed by authorized approver, or having been altered without authorization, or having not been stamped by the “Dedicated Testing/Inspection Stamp” is deemed to be invalid. Copying or excerpting portion of, or altering the content of the report is not permitted without the written authorization of AGC. The test results presented in the report apply only to the tested sample. Any objections to report issued by AGC should be submitted to AGC within 15days after the issuance of the test report. Further enquiry of validity or verification of the test report should be addressed to AGC by [agc01@agccert.com](mailto:agc01@agccert.com).

## EN 61000-4-8 PFMF TEST SETUP



Any report having not been signed by authorized approver, or having been altered without authorization, or having not been stamped by the “Dedicated Testing/Inspection Stamp” is deemed to be invalid. Copying or excerpting portion of, or altering the content of the report is not permitted without the written authorization of AGC. The test results presented in the report apply only to the tested sample. Any objections to report issued by AGC should be submitted to AGC within 15days after the issuance of the test report. Further enquiry of validity or verification of the test report should be addressed to AGC by [agc01@agccert.com](mailto:agc01@agccert.com).

### APPENDIX B: PHOTOGRAPHS OF EUT

#### ALL VIEW OF EUT

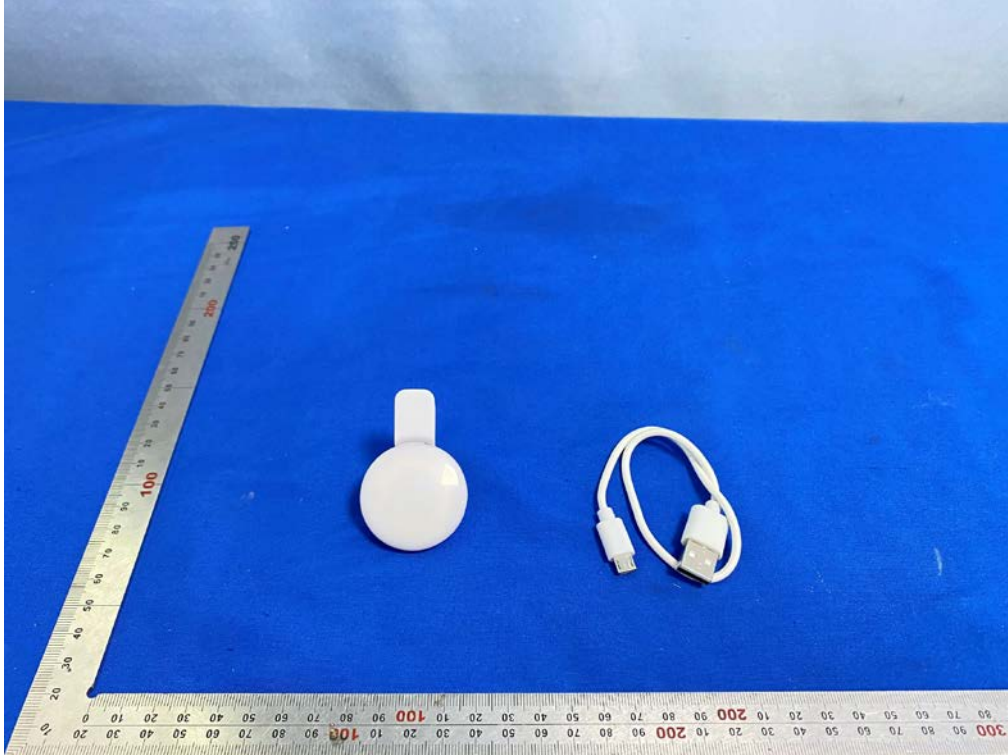

#### TOP VIEW OF EUT

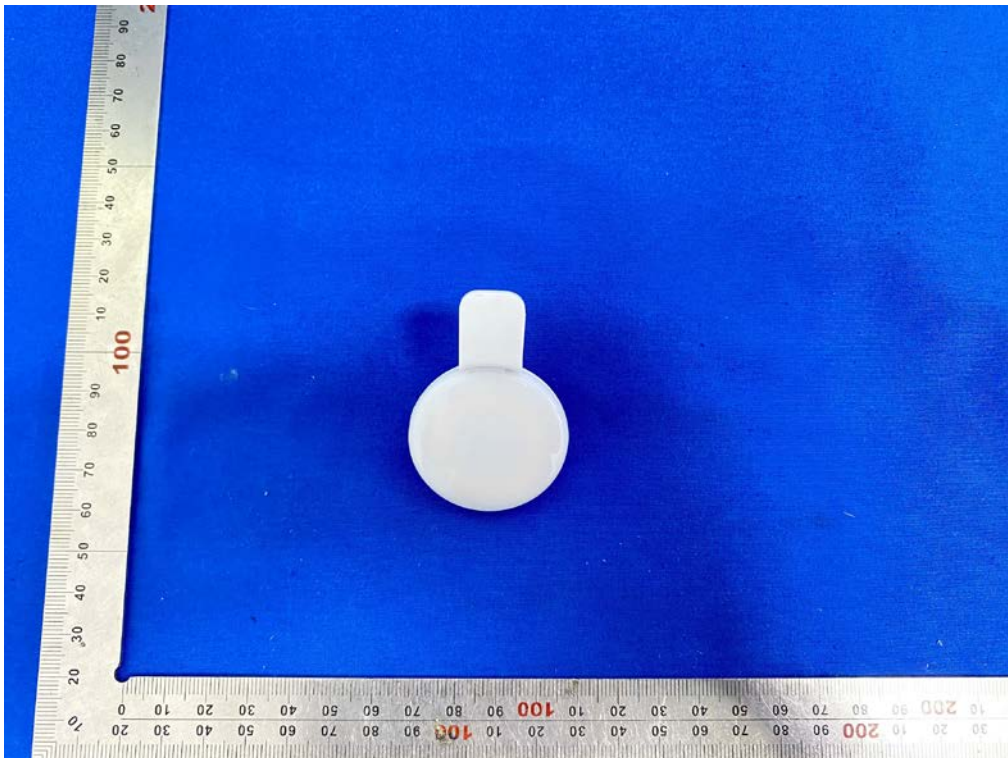

Any report having not been signed by authorized approver, or having been altered without authorization, or having not been stamped by the “Dedicated Testing/Inspection Stamp” is deemed to be invalid. Copying or excerpting portion of, or altering the content of the report is not permitted without the written authorization of AGC. The test results presented in the report apply only to the tested sample. Any objections to report issued by AGC should be submitted to AGC within 15days after the issuance of the test report. Further enquiry of validity or verification of the test report should be addressed to AGC by [agc01@agccert.com](mailto:agc01@agccert.com).

Attestation of Global Compliance(Shenzhen)Co., Ltd

Attestation of Global Compliance(Shenzhen)Std & Tech Co., Ltd

Tel: +86-755 2523 4088 E-mail: [agc@agccert.com](mailto:agc@agccert.com) Web: <http://www.agccert.com/>

BOTTOM VIEW OF EUT

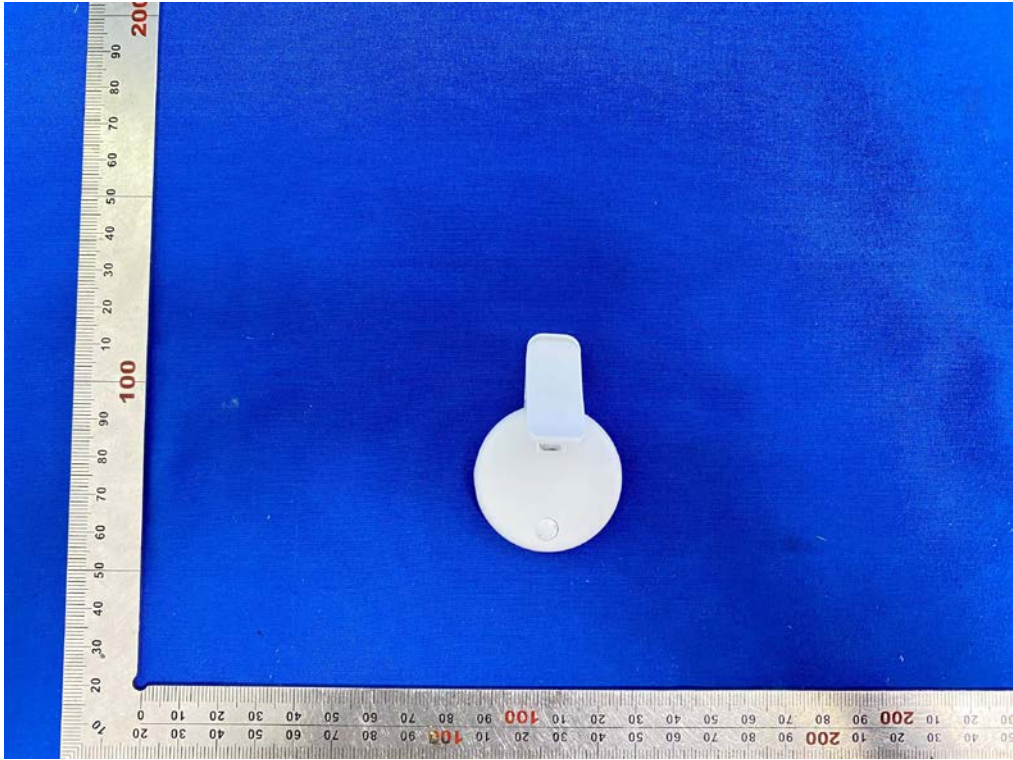

FRONT VIEW OF EUT

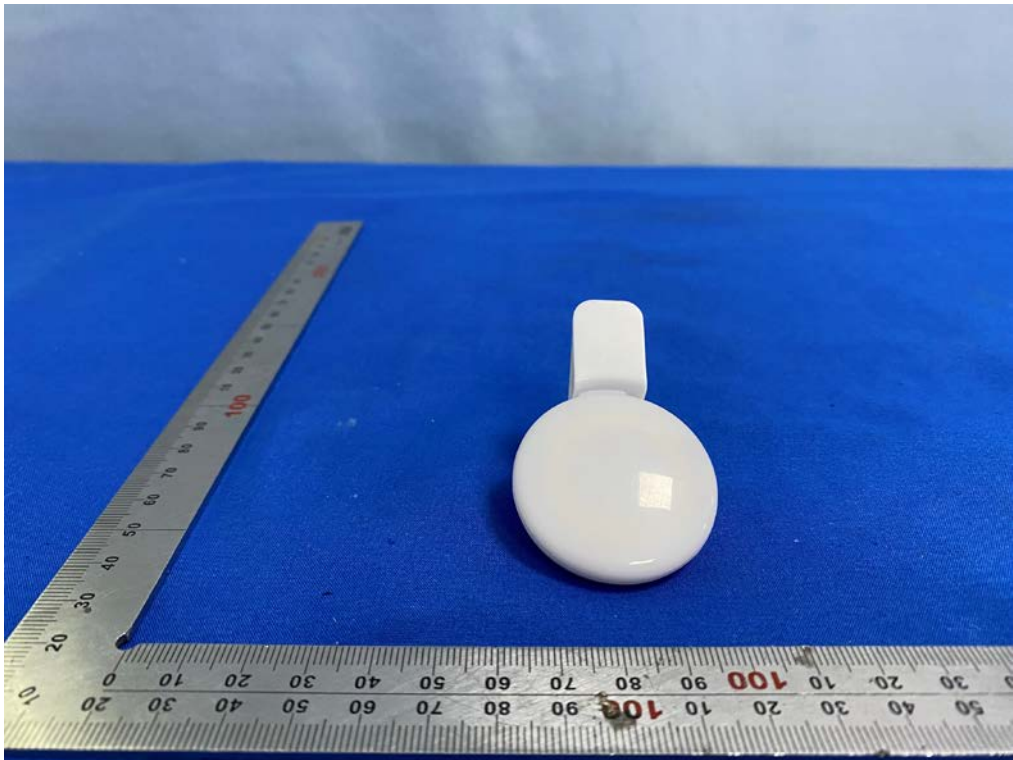

Any report having not been signed by authorized approver, or having been altered without authorization, or having not been stamped by the "Dedicated Testing/Inspection Stamp" is deemed to be invalid. Copying or excerpting portion of, or altering the content of the report is not permitted without the written authorization of AGC. The test results presented in the report apply only to the tested sample. Any objections to report issued by AGC should be submitted to AGC within 15days after the issuance of the test report. Further enquiry of validity or verification of the test report should be addressed to AGC by [agc01@agccert.com](mailto:agc01@agccert.com).

Attestation of Global Compliance(Shenzhen)Co., Ltd

Attestation of Global Compliance(Shenzhen)Std & Tech Co., Ltd

Tel: +86-755 2523 4088 E-mail: [agc@agccert.com](mailto:agc@agccert.com) Web: <http://www.agccert.com/>

BACK VIEW OF EUT

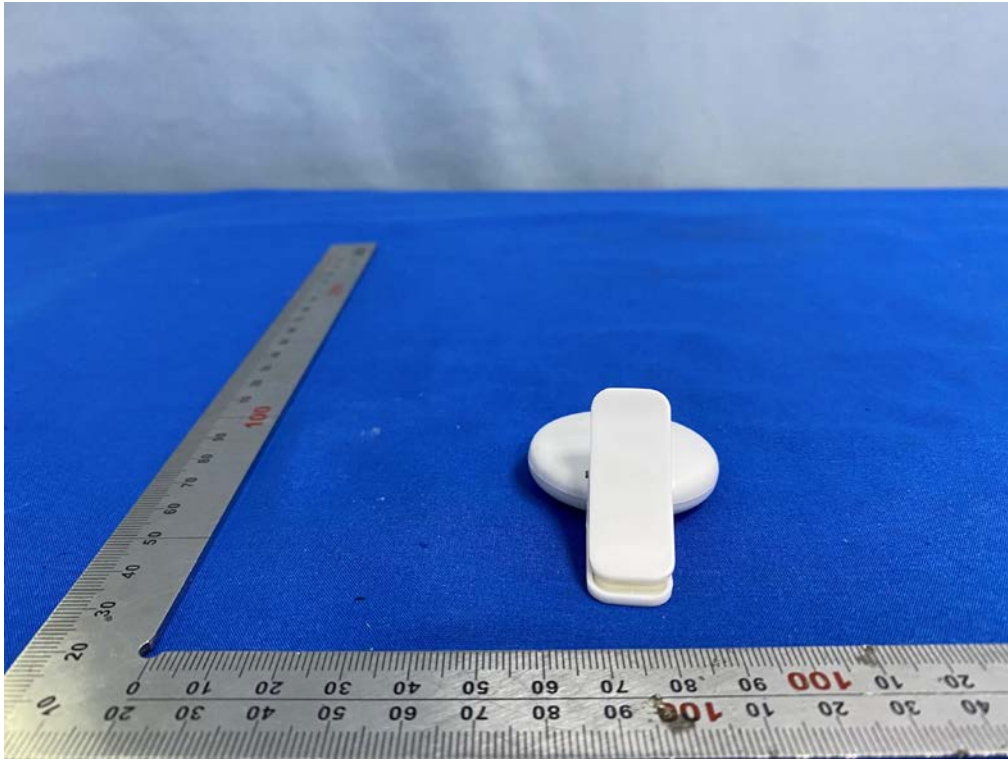

LEFT VIEW OF EUT

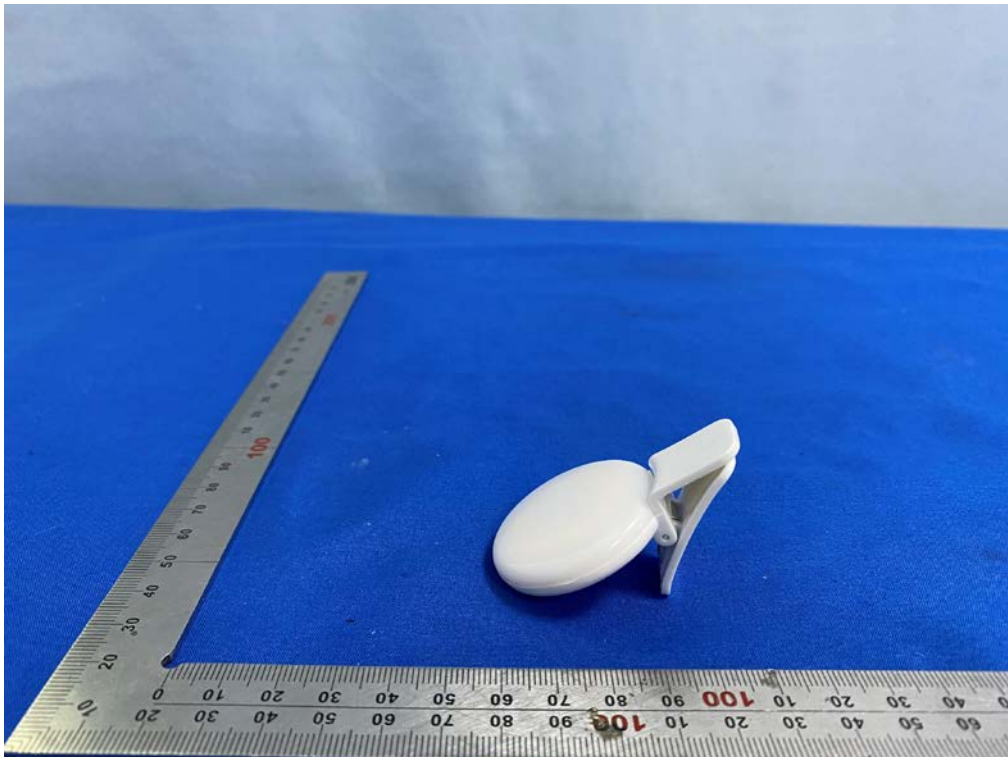

Any report having not been signed by authorized approver, or having been altered without authorization, or having not been stamped by the “Dedicated Testing/Inspection Stamp” is deemed to be invalid. Copying or excerpting portion of, or altering the content of the report is not permitted without the written authorization of AGC. The test results presented in the report apply only to the tested sample. Any objections to report issued by AGC should be submitted to AGC within 15days after the issuance of the test report. Further enquiry of validity or verification of the test report should be addressed to AGC by [agc01@agccert.com](mailto:agc01@agccert.com).

Attestation of Global Compliance(Shenzhen)Co., Ltd

Attestation of Global Compliance(Shenzhen)Std & Tech Co., Ltd

Tel: +86-755 2523 4088 E-mail: [agc@agccert.com](mailto:agc@agccert.com) Web: <http://www.agccert.com/>

RIGHT VIEW OF EUT

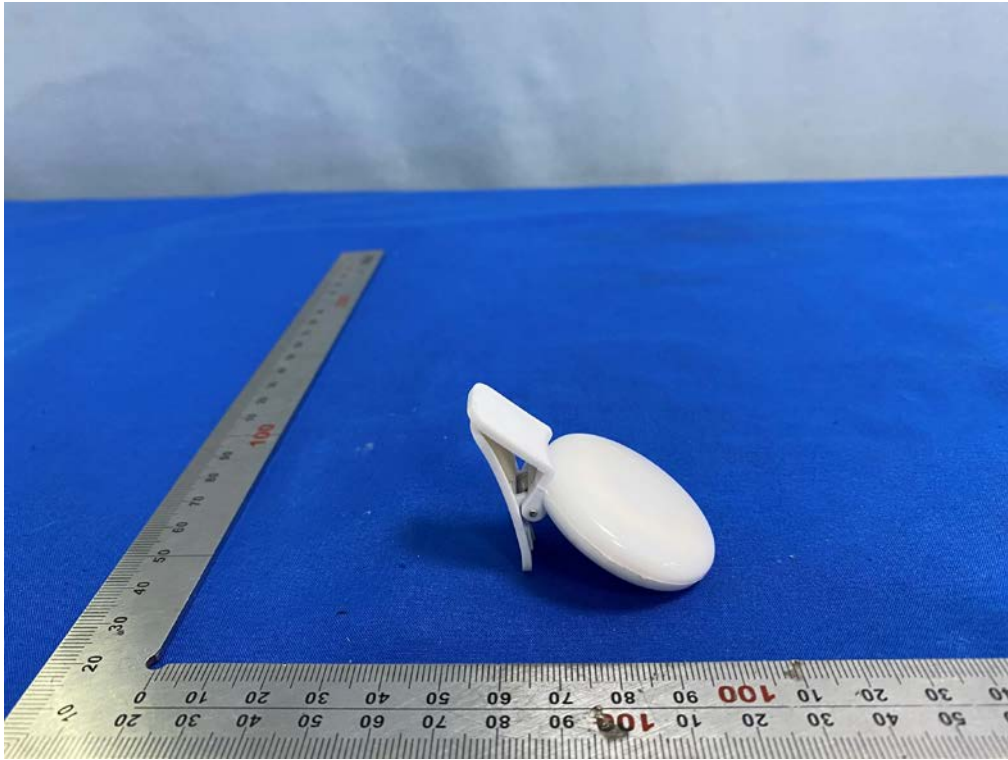

OPEN VIEW OF EUT-1

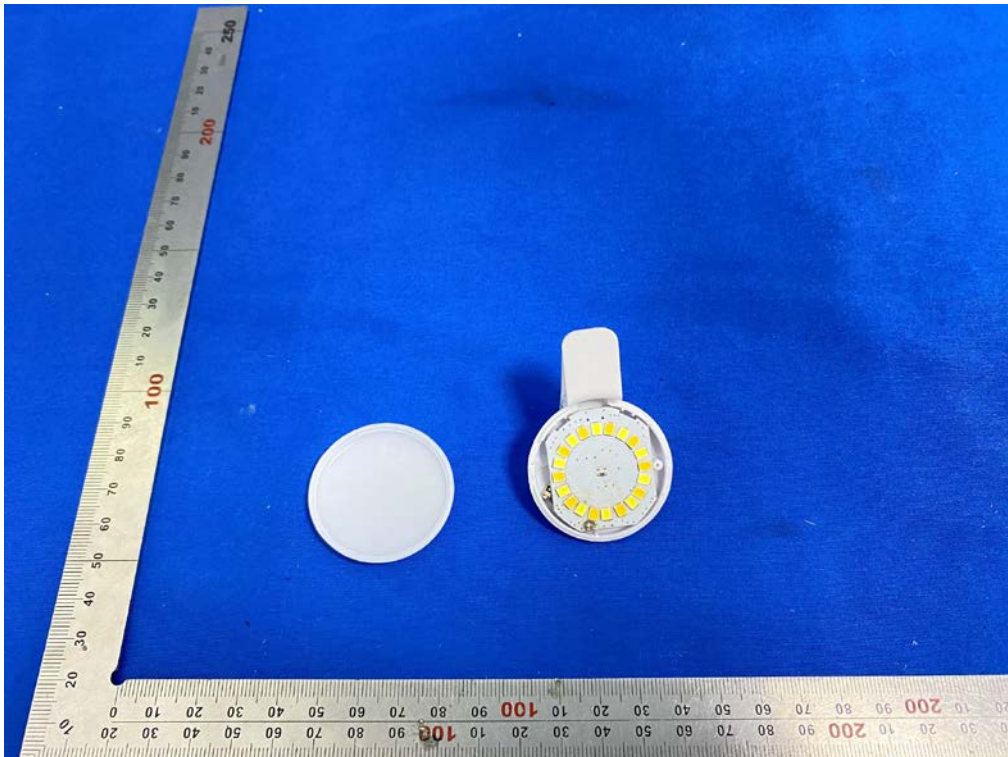

Any report having not been signed by authorized approver, or having been altered without authorization, or having not been stamped by the "Dedicated Testing/Inspection Stamp" is deemed to be invalid. Copying or excerpting portion of, or altering the content of the report is not permitted without the written authorization of AGC. The test results presented in the report apply only to the tested sample. Any objections to report issued by AGC should be submitted to AGC within 15days after the issuance of the test report. Further enquiry of validity or verification of the test report should be addressed to AGC by [agc01@agccert.com](mailto:agc01@agccert.com).

INTERNAL VIEW OF EUT-1

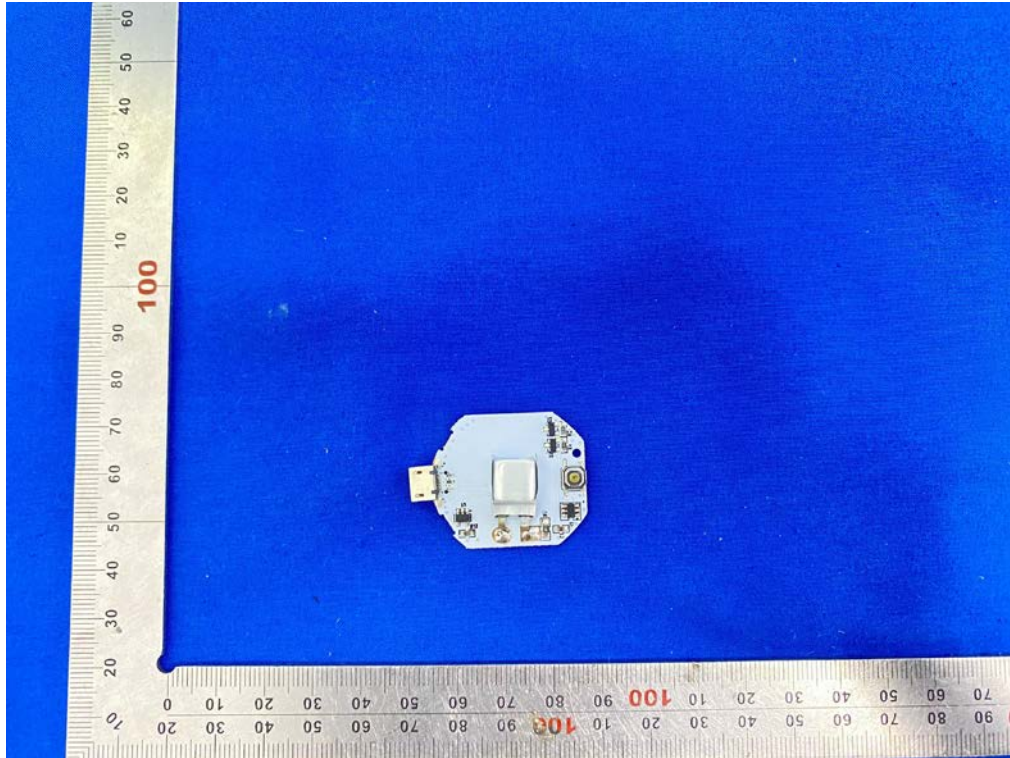

INTERNAL VIEW OF EUT-2

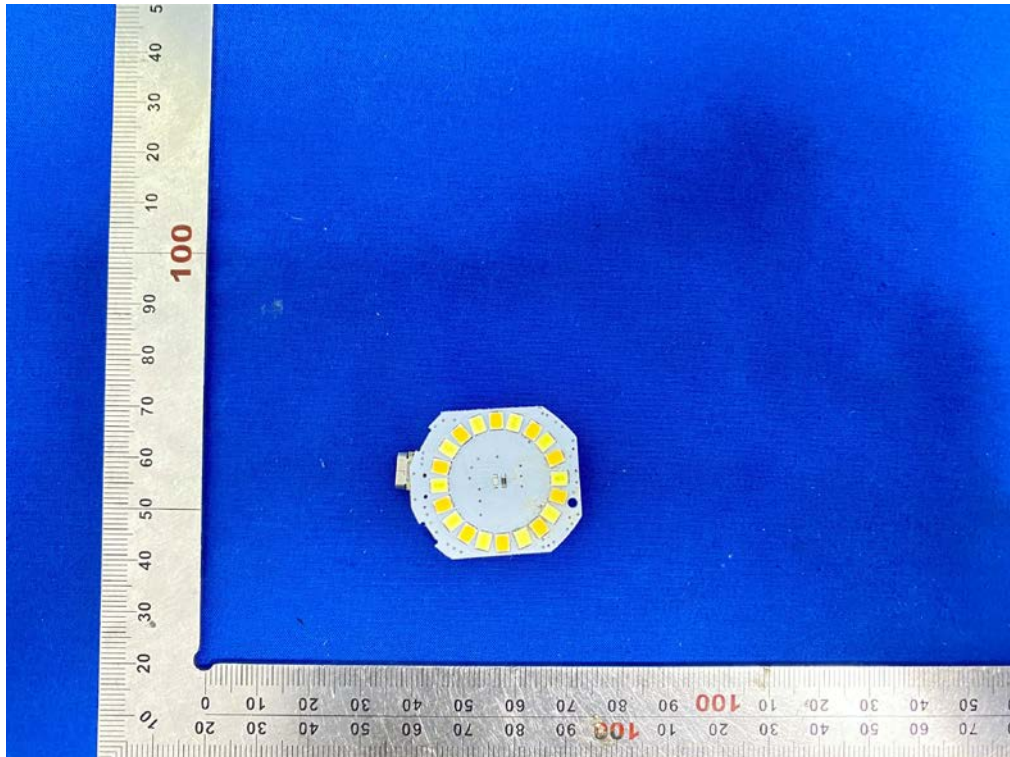

----END OF REPORT----

Any report having not been signed by authorized approver, or having been altered without authorization, or having not been stamped by the "Dedicated Testing/Inspection Stamp" is deemed to be invalid. Copying or excerpting portion of, or altering the content of the report is not permitted without the written authorization of AGC. The test results presented in the report apply only to the tested sample. Any objections to report issued by AGC should be submitted to AGC within 15days after the issuance of the test report. Further enquiry of validity or verification of the test report should be addressed to AGC by [agc01@agccert.com](mailto:agc01@agccert.com).

Attestation of Global Compliance(Shenzhen)Co., Ltd  
Attestation of Global Compliance(Shenzhen)Std & Tech Co., Ltd  
Tel: +86-755 2523 4088 E-mail: [agc@agccert.com](mailto:agc@agccert.com) Web: <http://www.agccert.com/>



## Conditions of Issuance of Test Reports

1. All samples and goods are accepted by the Attestation of Global Compliance (Shenzhen) Co., Ltd (the “Company”) solely for testing and reporting in accordance with the following terms and conditions. The company provides its services on the basis that such terms and conditions constitute express agreement between the company and any person, firm or company requesting its services (the “Clients”).
2. Any report issued by Company as a result of this application for testing services (the “Report”) shall be issued in confidence to the Clients and the Report will be strictly treated as such by the Company. It may not be reproduced either in its entirety or in part and it may not be used for advertising or other unauthorized purposes without the written consent of the Company. The Clients to whom the Report is issued may, however, show or send it, or a certified copy thereof prepared by the Company to its customer, supplier or other persons directly concerned. The Company will not, without the consent of the Clients, enter into any discussion or correspondence with any third party concerning the contents of the Report, unless required by the relevant governmental authorities, laws or court orders.
3. The Company shall not be called or be liable to be called to give evidence or testimony on the Report in a court of law without its prior written consent, unless required by the relevant governmental authorities, laws or court orders.
4. In the event of the improper use of the report as determined by the Company, the Company reserves the right to withdraw it, and to adopt any other additional remedies which may be appropriate.
5. Samples submitted for testing are accepted on the understanding that the Report issued cannot form the basis of, or be the instrument for, any legal action against the Company.
6. The Company will not be liable for or accept responsibility for any loss or damage however arising from the use of information contained in any of its Reports or in any communication whatsoever about its said tests or investigations.
7. Clients wishing to use the Report in court proceedings or arbitration shall inform the Company to that effect prior to submitting the sample for testing.
8. The Company is not responsible for recalling the electronic version of the original report when any revision is made to them. The Client assumes the responsibility to providing the revised version to any interested party who uses them.
9. Subject to the variable length of retention time for test data and report stored hereinto as otherwise specifically required by individual accreditation authorities, the Company will only keep the supporting test data and information of the test report for a period of six years. The data and information will be disposed of after the aforementioned retention period has elapsed. Under no circumstances shall we provide any data and information which has been disposed of after retention period. Under no circumstances shall we be liable for damage of any kind, including (but not limited to) compensatory damages, lost profits, lost data, or any form of special, incidental, indirect, consequential or punitive damages of any kind, whether based on breach of contract of warranty, tort (including negligence), product liability or otherwise, even if we are informed in advance of the possibility of such damages.

Any report having not been signed by authorized approver, or having been altered without authorization, or having not been stamped by the “Dedicated Testing/Inspection Stamp” is deemed to be invalid. Copying or excerpting portion of, or altering the content of the report is not permitted without the written authorization of AGC. The test results presented in the report apply only to the tested sample. Any objections to report issued by AGC should be submitted to AGC within 15 days after the issuance of the test report. Further enquiry of validity or verification of the test report should be addressed to AGC by [agc01@agccert.com](mailto:agc01@agccert.com).