

EMC TEST REPORT

For

Mid Ocean Brands B.V.

Bamboo wireless charger

Test Model: MO6390

Prepared for : Mid Ocean Brands B.V.
Address : 7/F., Kings Tower, 111 King Lam Street, Cheung Sha Wan,
Kowloon, Hong Kong

Prepared by : Shenzhen SIT Testing Technology Co., Ltd.
Address : Room 401, Building A2, The 2nd Industrial Zone of Zhu'ao,
Gushu, Xixiang, Bao'an District, Shenzhen, Guangdong,
China

Tel : (+86)755-29173399
Fax : (+86)755-29179933

Date of receipt of test sample : April 07, 2024
Number of tested samples : 1
Serial number : Prototype
Date of Test : April 07, 2024~ April 12, 2024
Date of Report : April 12, 2024



<p>EMC TEST REPORT ETSI EN 301 489-3 V2.3.2 (2023-01) ElectroMagnetic Compatibility (EMC) standard for radio equipment and services; Part 3: Specific conditions for Short-Range Devices (SRD) operating on frequencies between 9 kHz and 246 GHz; Harmonised Standard covering the essential requirements of article 3.1(b) of Directive 2014/53/EU</p>	
<p>Report Reference No. : SIT240328160201ER-1</p>	
<p>Date Of Issue : April 12, 2024</p>	
<p>Testing Laboratory Name : Shenzhen SIT Testing Technology Co., Ltd. Address : Room 401, Building A2, The 2nd Industrial Zone of Zhu'ao, Gushu, Xixiang, Bao'an District, Shenzhen, Guangdong, China Testing Location/ Procedure : Full application of Harmonised standards <input checked="" type="checkbox"/> Partial application of Harmonised standards <input type="checkbox"/> Other standard testing method <input type="checkbox"/></p>	
<p>Applicant's Name : Mid Ocean Brands B.V. Address : 7/F., Kings Tower, 111 King Lam Street, Cheung Sha Wan, Kowloon, Hong Kong</p>	
<p>Test Specification Standard..... : ETSI EN 301 489-1 V2.2.3 (2019-11) ETSI EN 301 489-3 V2.3.2 (2023-01) Test Report Form No. : EMC-1.0 TRF Originator : Shenzhen SIT Testing Technology Co., Ltd. Master TRF..... : Dated 2017-02</p>	
<p>Shenzhen SIT Testing Technology Co., Ltd. All rights reserved. This publication may be reproduced in whole or in part for non-commercial purposes as long as the Shenzhen SIT Testing Technology Co., Ltd. is acknowledged as copyright owner and source of the material. Shenzhen SIT Testing Technology Co., Ltd. takes no responsibility for and will not assume liability for damages resulting from the reader's interpretation of the reproduced material due to its placement and context.</p>	
<p>Test Item Description. : Bamboo wireless charger Trade Mark : N/A Test Model : MO6390 Ratings : Input: 5V---2A, 9V---2A Output: 5V---1A, 7.5V---1A, 9V---1.1A Result : Positive</p>	

Compiled by:

Debe Yu

Project Engineer

Supervised by:

Jessica

Project Supervisor

Approved by:

Kevin San

Technical Director

EMC -- TEST REPORT

Test Report No. : SIT240328160201ER-1	<u>April 12, 2024</u> Date of issue
--	--

Test Model	: MO6390
EUT.....	: Bamboo wireless charger
Applicant.....	: Mid Ocean Brands B.V.
Address.....	: 2nd Floor, Building8, Huashen Industrial Park, Guangming District, Shenzhen, China
Telephone.....	: /
Fax.....	: /
Manufacturer.....	: 114628
Address.....	: /
Telephone.....	: /
Fax.....	: /

Test Result	Positive
--------------------	-----------------

The test report merely corresponds to the test sample.
It is not permitted to copy extracts of these test result without the written permission of the test laboratory.

Revision History

Revision	Issue Date	Revisions	Revised By
00	April 11, 2024	Initial Issue	Kevin Sun

TABLE OF CONTENT

Test Report Description	Page
TABLE OF CONTENT	5
1. GENERAL INFORMATION	7
1.1. Product Description for Equipment Under Test (EUT).....	7
1.2. Objective.....	7
1.3. Related Submittal(s)/Grant(s).....	7
1.4. Test Methodology.....	7
1.5. Description of Test Facility.....	8
1.6. Support equipment List.....	8
1.7. External I/O.....	8
1.8. Measurement Uncertainty.....	8
1.9. Description Of Test Modes.....	8
2. SUMMARY OF TEST RESULTS	9
3. LINE CONDUCTED EMISSION	10
3.1. CONDUCTED EMISSION LIMIT	10
3.2. TEST CONFIGURATION.....	10
3.3. EMI TEST RECEIVER SETUP.....	10
3.4. TEST PROCEDURE.....	11
4. RADIATED DISTURBANCE	13
4.1. Radiated Emission Limit	13
4.2. Test Configuration.....	13
4.3. Test Procedure.....	13
4.4. Test Data.....	13
5. HARMONIC CURRENT EMISSIONS	16
5.1. Test Configuration.....	16
5.2. Test Standard.....	16
5.3. Test Data.....	16
6. VOLTAGE FLUCTUATION AND FLICKER	18
6.1. Test Configuration.....	18
6.2. Test Standard.....	18
7. GENERAL PERFORMANCE CRITERIA FOR IMMUNITY TEST	19
7.1. Performance criteria for Continuous phenomena applied to Transmitter (CT).....	19
7.2. Performance criteria for Transient phenomena applied to Transmitter (TT).....	19
7.3. Performance criteria for Continuous phenomena applied to Receiver (CR).....	19
7.4. Performance criteria for Transient phenomena applied to Receiver (TR).....	19
8. RF ELECTROMAGNETIC FIELD (80 MHZ -6000 MHZ)	20
8.1. Test Configuration.....	20
8.2. Test Standard.....	21
8.3. Severity Level.....	21
8.4. Test Procedure.....	21
8.5. Test Result.....	22
9. ELECTROSTATIC DISCHARGE	23
9.1. Test Configuration.....	23
9.2. Test Procedure.....	23
9.3. Test Data.....	24
10. ELECTRICAL FAST TRANSIENT IMMUNITY	26

10.1. Test Configuration 26

10.2. Test Standard 26

10.3. Test Procedure 27

10.4. Test Data 27

11. RF COMMON MODE 29

11.1. Test Configuration 29

11.2. Test Standard 29

11.3. Test Procedure 30

11.4. Test Data 30

12. SURGES, LINE TO LINE AND LINE TO GROUND 32

12.1. Test Configuration 32

12.2. Test Standard 32

12.3. Test Procedure 32

12.4. Test Data 33

13. VOLTAGE DIPS/INTERRUPTIONS IMMUNITY TEST 34

13.1. Test Configuration 34

13.2. Test Standard 34

13.3. Test Procedure 34

13.4. Test Data 35

14. LIST OF MEASURING EQUIPMENT 36

15. PHOTOGRAPHS OF TEST SETUP..... 37

16. EXTERNAL AND INTERNAL PHOTOS OF THE EUT..... 38

1. GENERAL INFORMATION

1.1. Product Description for Equipment Under Test (EUT)

EUT : Bamboo wireless charger
 Test Model : MO6390
 Power Supply : Input: 5V \pm 2A, 9V \pm 2A
 : Output: 5V \pm 1A, 7.5V \pm 1A, 9V \pm 1.1A
 Number of Channels : 1
 Modulation Type : GSKF
 Antenna Description : Ferrite Antenna, 2 dBi(Max.)

1.2. Objective

ETSI EN 301 489-1	ElectroMagnetic Compatibility (EMC) standard for radio equipment and services; Part 1: Common technical requirements; Harmonised Standard covering the essential requirements of article 3.1(b) of Directive 2014/53/EU and the essential requirements of article 6 of Directive 2014/30/EU
ETSI EN 301 489-3	ElectroMagnetic Compatibility (EMC) standard for radio equipment and services; Part 3: Specific conditions for Short-Range Devices (SRD) operating on frequencies between 9 kHz and 246 GHz; Harmonised Standard covering the essential requirements of article 3.1(b) of Directive 2014/53/EU

The objective is to determine compliance with ETSI EN 301 489-1 V2.2.3 (2019-11) and ETSI EN 301 489-3 V2.3.2 (2023-01).

1.3. Related Submittal(s)/Grant(s)

No Related Submittals.

1.4. Test Methodology

All measurements contained in this report were conducted with ETSI EN 301 489-1 V2.2.3 (2019-11) and ETSI EN 301 489-3 V2.3.2 (2023-01).

1.5. Description of Test Facility

Not mentioned for the time being

1.6. Support equipment List

Manufacturer	Description	Model	Serial Number	Certificate
--	--	--	--	--

1.7. External I/O

I/O Port Description	Quantity	Cable
USB port	1	--

1.8. Measurement Uncertainty

Item	MU	Remark
Uncertainty for Power point Conducted Emissions Test	2.42dB	
Uncertainty for Radiation Emission test in 3m chamber (30MHz to 1GHz)	3.54dB	Polarize: V
	4.1dB	Polarize: H
Uncertainty for Radiation Emission test in 3m chamber (1GHz to 25GHz)	2.08dB	Polarize: H
	2.56dB	Polarize: V
Uncertainty for radio frequency	0.01ppm	
Uncertainty for conducted RF Power	0.65dB	
Uncertainty for temperature	0.2℃	
Uncertainty for humidity	1%	
Uncertainty for DC and low frequency voltages	0.06%	

1.9. Description Of Test Modes

TM1: Normal operation

TM2: Idle

***Note:

All test modes were tested, but we only recorded the worst case in this report.

2. SUMMARY OF TEST RESULTS

Rule	Description of Test Items	Result
§7.1	Reference to clauses EN 301 489-1 §8.4 AC mains power input/output ports	Compliant
§7.1	Reference to clauses EN 301 489-1§8.3 DC power input/output ports	N/A
§7.1	Reference to clauses EN 301 489-1 §8.2 Enclosure of ancillary equipment measured on a stand alone basis	Compliant
§7.1	Reference to clauses EN 301 489-1 §8.5 Harmonic current emissions (AC mains input port)	N/A
§7.1	Reference to clauses EN 301 489-1 §8.6 Voltage fluctuations and flicker (AC mains input port)	Compliant
§7.1	Reference to clauses EN 301 489-1§8.7 Telecommunication ports	N/A
§7.2	Reference to clauses EN 301 489-1 §9.3 Electrostatic discharge (EN 61000-4-2)	Compliant
§7.2	Reference to clauses EN 301 489-1 §9.2 Radio frequency electromagnetic field (80 MHz to 6 000 MHz)(EN 61000-4-3)	Compliant
§7.2	Reference to clauses EN 301 489-1§9.4 Fast transients, common mode (EN 61000-4-4)	Compliant
§7.2	Reference to clauses EN 301 489-1§9.8 Surges (EN 61000-4-5)	Compliant
§7.2	Reference to clauses EN 301 489-1§9.5 Radio frequency, common mode (EN 61000-4-6)	Compliant
§7.2	Reference to clauses EN 301 489-1 §9.6 Transients and surges in the vehicular environment (ISO 7637-2)	N/A
§7.2	Reference to clauses EN 301 489-1§9.7 Voltage dips and interruptions (EN 61000-4-11)	Compliant

3. LINE CONDUCTED EMISSION

3.1. Conducted Emission Limit

ETSI EN 301 489-1 V2.2.3 (2019-11)/EN 55032 Class B

Limits for Power Line Conducted Emission

Frequency (MHz)	Limit (dB μ V)	
	Quasi-peak Level	Average Level
0.15 ~ 0.50	66.0 ~ 56.0 *	56.0 ~ 46.0 *
0.50 ~ 5.00	56.0	46.0
5.00 ~ 30.00	60.0	50.0

NOTE1-The lower limit shall apply at the transition frequencies.
NOTE2-The limit decreases linearly with the logarithm of the frequency in the range 0.15MHz to 0.50MHz.

3.2. Test Configuration

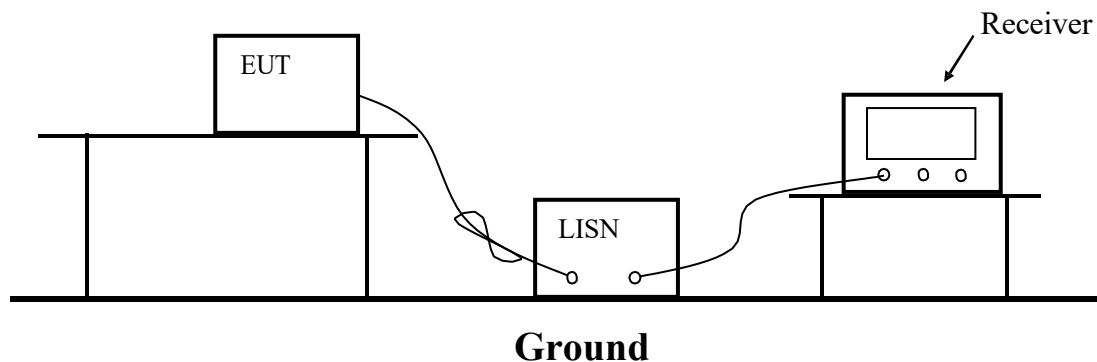

The setup of EUT is according with per ETSI EN 301 489-1 measurement procedure. The specification used was with the ETSI EN 301 489-1 limits.

The external I/O cables were draped along the test table and formed a bundle 30 to 40 cm long in the middle.

The spacing between the peripherals was 10 cm.

The EUT received DC 9V Charging power from adapter which received power through a LISN supplying power of DC 9V/50Hz.

3.3. EMI Test Receiver Setup

The EMI test receiver was set to investigate the spectrum from 150 kHz to 30 MHz.

During the conducted emission test, the EMI test receiver was set with the following configurations:

Frequency Range
150 kHz – 30 MHz

IFBW
9 kHz

3.4. Test Procedure

Power on the EUT, the EUT begins to work. Make sure the EUT operates normally during the test.

Maximizing procedure was performed on the six (6) highest emissions of the EUT.

All data was recorded in the Quasi-peak and average detection mode.

4. RADIATED DISTURBANCE

4.1. Radiated Emission Limit

ETSI EN 301 489-1 V2.2.3 (2019-11)/EN 55032 Class B

Limits for radiated disturbance Blow 1GHz

FREQUENCY (MHz)	DISTANCE (Meters)	FIELD STRENGTHS LIMIT (dB μ V/m)
30 ~ 230	3	40
230 ~ 1000	3	47

Note: (1) The smaller limit shall apply at the combination point between two frequency bands. (2) Distance refers to the distance in meters between the measuring instrument antenna and the closed point of any part of the EUT.

Limits for radiated disturbance Above 1GHz

FREQUENCY (MHz)	DISTANCE (Meters)	Average Limit (dB μ V/m)	Peak Limit (dB μ V/m)
1000-3000	3	50	70
3000-6000	3	54	74

Note: The lower limit applies at the transition frequency.

4.2. Test Configuration

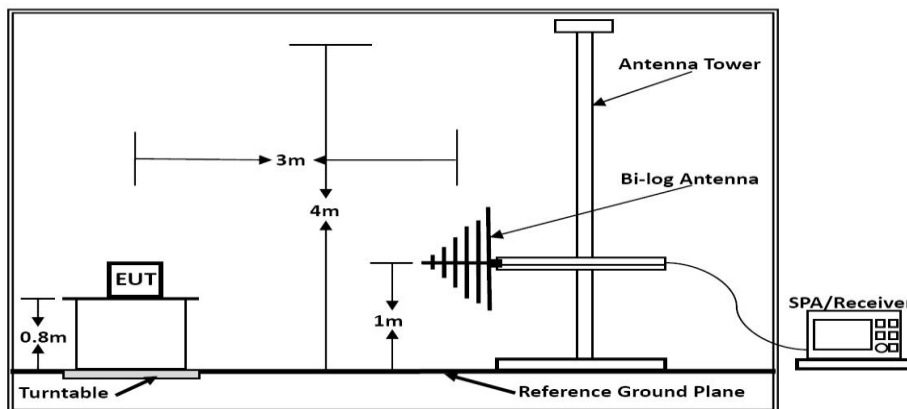

Below 1GHz

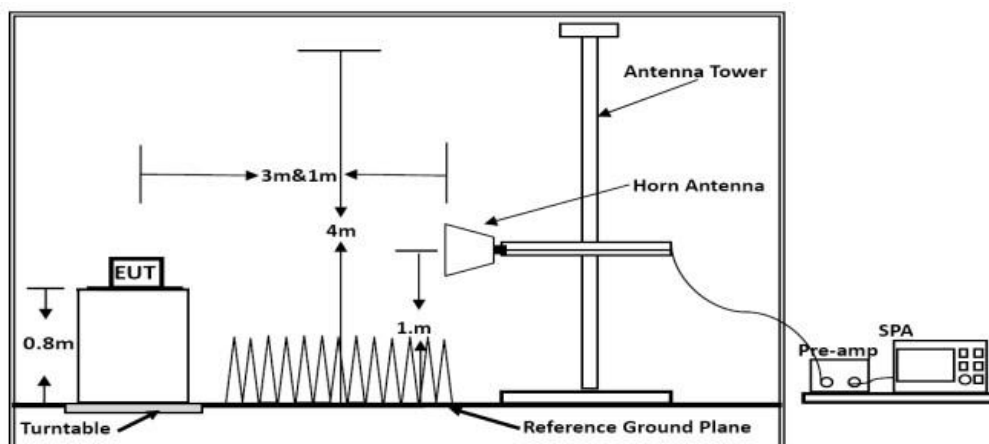

Above 1GHz

4.3. Test Procedure

Please refer to ETSI EN 301 489-1 Clause 8.2.3 and EN 55032 Annex A.2 for the measurement methods.

4.4. Test Data

The worst test mode of the EUT was TM1, and its test data was showed as the follow:

Model No.	MO6390	Test Mode	DC 9V
Environmental Conditions	24°C,44.2% RH	Detector Function	Quasi-peak
Pol	Vertical	Distance	3m
Test Engineer	DebeYu	Test date:	April 09, 2024

Radiated Emission Measurement

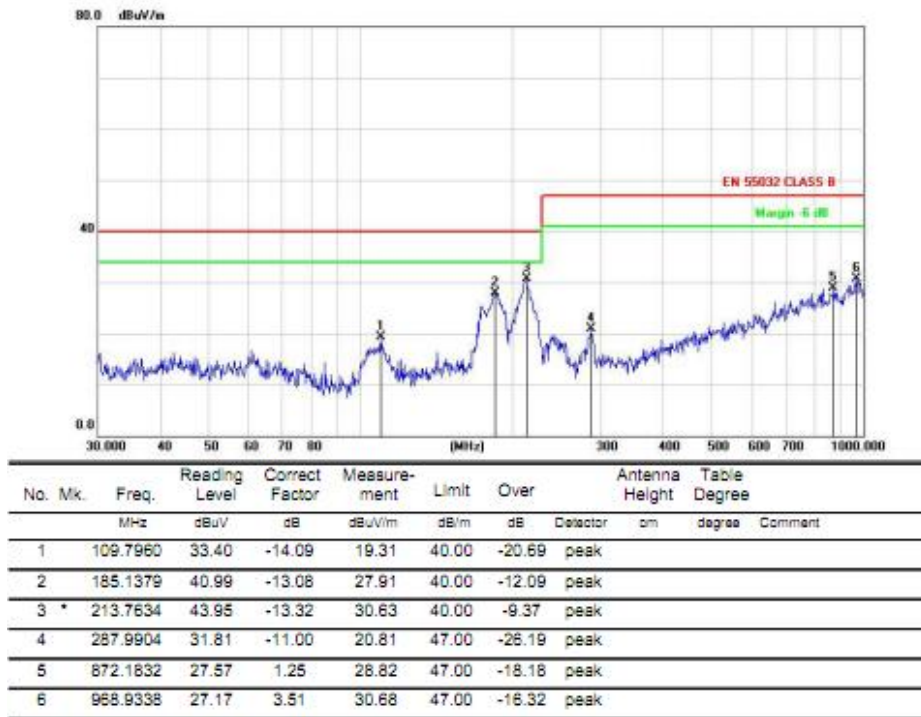

Model No.	MO6390	Test Mode	DC 9V
Environmental Conditions	24°C,44.2% RH	Detector Function	Quasi-peak
Pol	Horizontal	Distance	3m
Test Engineer	DebeYu	Test date:	April 09, 2024

Radiated Emission Measurement

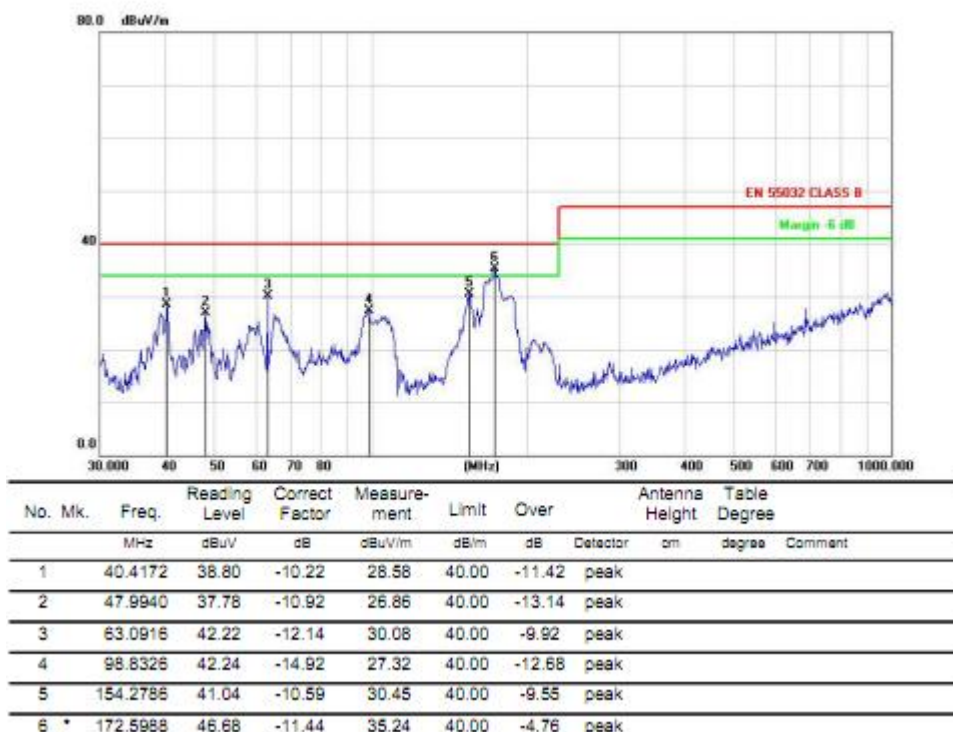

Test Mode: TM1(above 1GHz)	Tested by: DebeYu
Test voltage: DC 9V	Test Distance: 3m
Detector Function: Peak+AV	Test Results: Passed

Frequency MHz	Emission Level dB μ V/m		Limits dB μ V/m		Margin dB μ V/m		Polarization
	Peak	AV	Peak	AV	Peak	AV	
1352.37	48.26	36.79	70	50	-21.74	-13.21	H
1879.53	49.52	36.62	70	50	-20.48	-13.38	H
2191.53	46.67	37.25	70	50	-23.33	-12.75	H
3291.78	48.15	35.96	70	54	-21.85	-18.04	H
4330.17	57.24	37.41	70	54	-12.76	-16.59	H
5888.35	56.24	38.49	70	54	-13.76	-15.51	H
1351.38	56.39	38.76	70	50	-13.61	-11.24	V
1878.53	55.72	37.56	70	50	-14.28	-12.44	V
2190.06	58.32	38.46	70	50	-11.68	-11.54	V
3295.04	55.37	36.95	70	54	-14.63	-17.05	V
4332.73	55.41	38.24	70	54	-14.59	-15.76	V
5882.40	54.82	35.62	70	54	-15.18	-18.38	V

5. HARMONIC CURRENT EMISSIONS

5.1. Test Configuration

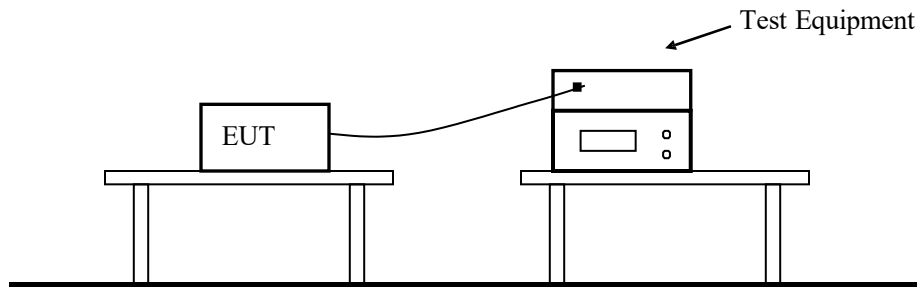

5.2. Test Standard

According to ETSI EN 301 489-1 V2.2.3 (2019-11)& EN 61000-3-2: 2019+A1:2021

5.3. Test Data

Because power of EUT less than 75W, According standard EN 61000-3-2, Harmonic current unnecessary to test.

6. VOLTAGE FLUCTUATION AND FLICKER

6.1. Test Configuration

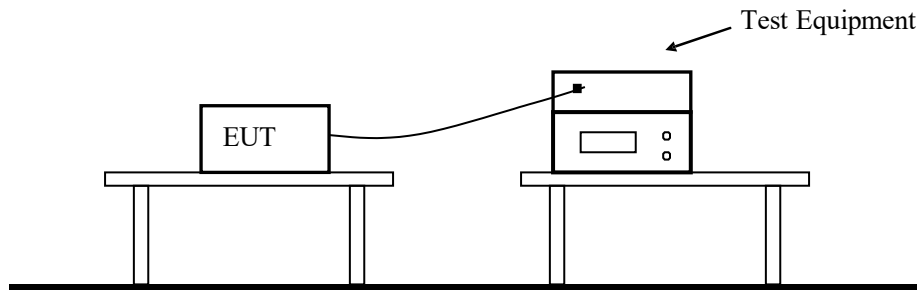

6.2. Test Standard

According to ETSI EN 301 489-1 V2.2.3 (2019-11)& EN 61000-3-3: 2013+A1:2019

7. GENERAL PERFORMANCE CRITERIA FOR IMMUNITY TEST

7.1. Performance criteria for Continuous phenomena applied to Transmitter (CT)

For equipment of type II or type III that requires a communication link that is maintained during the test, it shall be verified by appropriate means supplied by the manufacturer that the communication link is maintained during each individual exposure in the test sequence.

Where the EUT is a transmitter, tests shall be repeated with the EUT in standby mode to ensure that any unintentional transmission does not occur.

7.2. Performance criteria for Transient phenomena applied to Transmitter (TT)

For equipment of type II or type III that requires a communication link that is maintained during the test, this shall be verified by appropriate means supplied by the manufacturer during each individual exposure in the test sequence. Where the EUT is a transmitter, tests shall be repeated with the EUT in standby mode to ensure that any unintentional transmission does not occur.

7.3. Performance criteria for Continuous phenomena applied to Receiver (CR)

For equipment of type II or III that requires a communication link that is maintained during the test, it shall be verified by appropriate means supplied by the manufacturer that the communication link is maintained during each individual exposure in the test sequence. Where the EUT is a transceiver, under no circumstances shall the transmitter operate unintentionally during the test.

7.4. Performance criteria for Transient phenomena applied to Receiver (TR)

For equipment of type II or type III that requires a communication link that is maintained during the test, this shall be verified by appropriate means supplied by the manufacturer during each individual exposure in the test sequence. Where the EUT is a transceiver, under no circumstances shall the transmitter operate unintentionally during the test.

Performance criteria for ETSI EN 301 489-3 V2.3.2 (2023-01)

Criterion	During test	After test
A	Operate as intended No loss of function No unintentional responses	Operate as intended No loss of function No degradation of performance No loss of stored data or user programmable functions
B	May show loss of function No unintentional responses	Operate as intended Lost function(s) shall be self-recoverable No degradation of performance No loss of stored data or user programmable functions

8. RF ELECTROMAGNETIC FIELD (80 MHZ -6000 MHZ)

8.1. Test Configuration

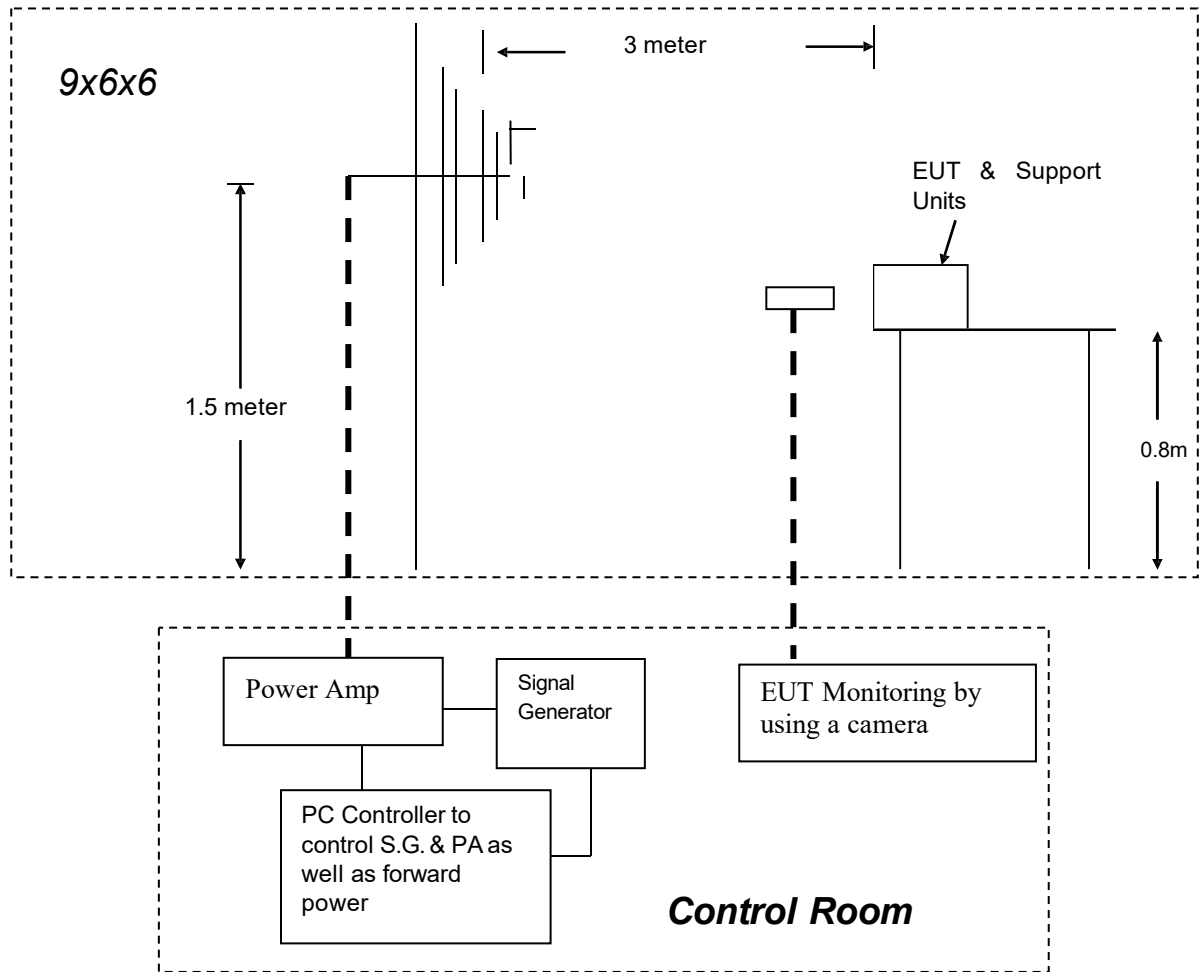

8.2. Test Standard

ETSI EN 301 489-1, ETSI EN 301 489-3(EN 61000-4-3: 2020)

Test level 2 at 3V / m.

8.3. Severity Level

Level	Field Strength V/m
1.	1
2.	3
3.	10
X	Special

Performance criterion: A

8.4. Test Procedure

The EUT and its simulators are placed on a turn table which is 0.8 meter above ground. EUT is set 3 meter away from the transmitting antenna which is mounted on an antenna tower. Both horizontal and vertical polarization of the antenna are set on test. Each of the four sides of EUT must be faced this transmitting antenna and measured individually. In order to judge the EUT performance, a CCD camera is used to monitor EUT screen. All the scanning conditions are as follows:

Condition of Test	Remarks
1. Fielded Strength	3 V/m (Severity Level 2)
2. Radiated Signal	Unmodulated
3. Scanning Frequency	80 - 6000 MHz
4. Dwell time of radiated	0.0015 decade/s
5. Waiting Time	3 Sec.

8.5. Test Result

RF ELECTROMAGNETIC FIELD			
Standard	<input type="checkbox"/> IEC 61000-4-3 <input checked="" type="checkbox"/> EN 61000-4-3		
Applicant	Mid Ocean Brands B.V.		
EUT	Bamboo wireless charger	Temperature	24°C
M/N	MO6390	Humidity	44.2%
Test Mode	TM1-TM2	Criterion	B
Test Engineer	DebeYu	Test Date	April 09, 2024

EUT Working Mode	Antenna Polarity	Frequency (MHz)	Field Strength (V/m)	Observation	Position	Conclusion
Operating Mode	Vertical	80-6000	3	See Note	Front, Right, Left, Back	Pass
	Horizontal	80-6000	3	See Note	Front, Right, Left, Back	Pass
Idle	Vertical	80-6000	3	See Note	Front, Right, Left, Back	Pass
	Horizontal	80-6000	3	See Note	Front, Right, Left, Back	Pass

***Note: Unintentional transmission is not founded from the EUT.

9. ELECTROSTATIC DISCHARGE

Please refer to ETSI EN 301 489-1 and EN 61000-4-2.

9.1. Test Configuration

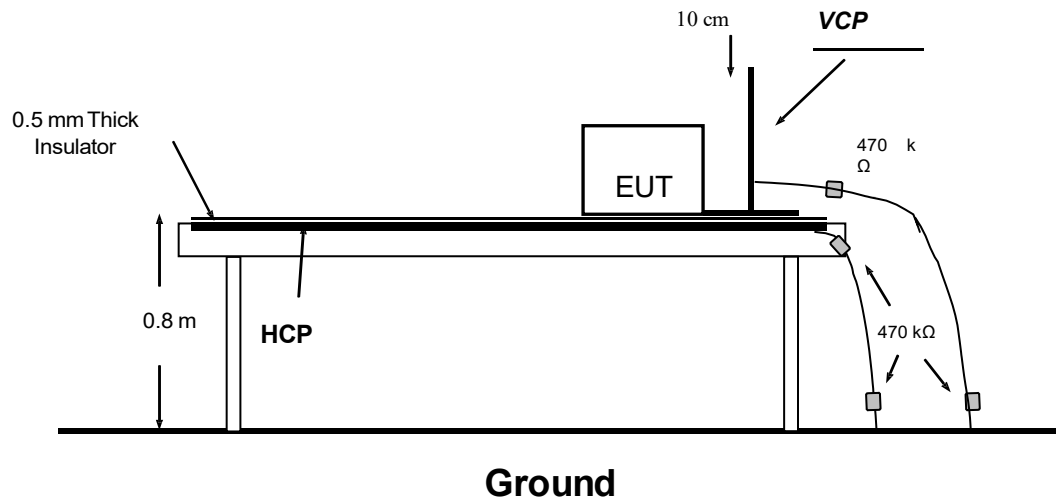

EN 61000-4-2 specifies that a tabletop EUT shall be placed on a non-conducting table which is 80 centimeters above a ground reference plane and that floor mounted equipment shall be placed on an insulating support approximately 10 centimeters above a ground plane. During the tests, the EUT is positioned over a ground reference plane in conformance with this requirement.

For tabletop equipment, a 1.5 by 1.0-meter metal sheet (HCP) is placed on the table and connected to the ground plane via a metal strap with two 470 k Ohms resistors in series. The EUT and attached cables are isolated from this metal sheet by 0.5-millimeter thick insulating material. A Vertical Coupling Plane (VCP) grounded on the ground plane through the same configuration as in the HCP is used.

9.2. Test Procedure

ETSI EN 301 489-1 V2.2.3 (2019-11)/ EN 61000-4-2: 2009

Test level 3 for Air Discharge at ± 8 kV

Test level 2 for Contact Discharge at ± 4 kV

9.2.1. Air Discharge

This test is done on a non-conductive surface. The round discharge tip of the discharge electrode shall be approached as fast as possible to touch the EUT. After each discharge, the discharge electrode shall be removed from the EUT. The generator is then re-triggered for a new single discharge and repeated 10 times for each pre-selected test point. This procedure shall be repeated until all the air discharge completed.

9.2.2. Contact Discharge

All the procedure shall be same as Section 9.2.1. except that the tip of the discharge electrode shall touch the EUT before the discharge switch is operated.

9.2.3. Indirect Discharge For Horizontal Coupling Plane

At least 10 single discharges (in the most sensitive polarity) shall be applied at the front edge of each HCP opposite the center point of each unit (if applicable) of the EUT and 0.1m from the front of the EUT. The long axis of the discharge electrode shall be in the plane of the HCP and perpendicular to its front edge during the discharge.

9.2.4. Indirect Discharge For Vertical Coupling Plane

At least 10 single discharges (in the most sensitive polarity) shall be applied to the center of one vertical edge of the coupling plane. The coupling plane, of dimensions 0.5m X 0.5m, is placed parallel to, and positioned at a distance of 0.1m from the EUT. Discharges shall be applied to the coupling plane, with this plane in sufficient different positions that the four faces of the EUT are completely illuminated.

9.3. Test Data

PASS.

Electrostatic Discharge Test Results

Standard	<input type="checkbox"/> IEC 61000-4-2 <input checked="" type="checkbox"/> EN 61000-4-2		
Applicant	Mid Ocean Brands B.V.		
EUT	Bamboo wireless charger	Temperature	23°C
M/N	MO6390	Humidity	44%
Criterion	B	Pressure	1021mbar
Test Mode	TM1-TM2	Test Date	April 09, 2024
Test Engineer	DebeYu		

TEST RESULT OF TM1-TM2

Test Voltage	Coupling	Observation	Result (Pass/Fail)
±2KV, ±4kV	Contact Discharge	TT, TR	Pass
±2KV, ±4kV, ±8kV	Air Discharge	TT, TR	Pass
±2KV, ±4kV	Indirect Discharge HCP	TT, TR	Pass
±2KV, ±4kV	Indirect Discharge VCP	TT, TR	Pass

Note:

The EUT performance complied with performance criteria for CT&CR to MS Function and there is no any degradation of performance and function.

10. ELECTRICAL FAST TRANSIENT IMMUNITY

10.1. Test Configuration

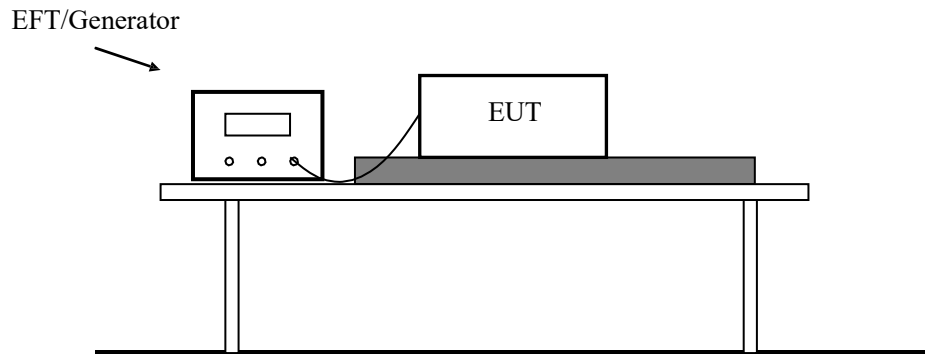

10.2. Test Standard

ETSI EN 301 489-1 V2.2.3/ EN61000-4-4: 2012
 Test level 2 at 1 kV

Test level

Level	Open Circuit Output Test Voltage $\pm 10\%$	
	On Power Supply Lines	On I/O (Input/Output) Signal data and control lines
1	0.5 kV	0.25 kV
2	1 kV	0.5 kV
3	2 kV	1 kV
4	4 kV	2 kV
X	Special	Special

Performance criterion: B

10.3. Test Procedure

The EUT is put on the table, which is 0.8 meter high above the ground. This reference ground plane shall project beyond the EUT by at least 0.1m on all sides and the minimum distance between EUT and all other conductive structure, except the ground plane beneath the EUT, shall be more than 0.5m.

10.4.1. For input and output AC power ports:

The EUT is connected to the power mains by using a coupling device, which couples the EFT interference signal to AC power lines. Both polarities of the test voltage should be applied during compliance test and the duration of the test is 2 minutes.

10.4.2. For signal lines and control lines ports: No I/O ports. It's unnecessary to test.

10.4.3. For DC output line ports: It's unnecessary to test.

10.4. Test Data

PASS.

Electrical Fast Transient/Burst Test Results

Standard	<input type="checkbox"/> IEC 61000-4-4 <input checked="" type="checkbox"/> EN 61000-4-4		
Applicant	Mid Ocean Brands B.V.		
EUT	Bamboo wireless charger	Temperature	25°C
M/N	MO6390	Humidity	45%
Test Mode	TM1-TM2	Criterion	B
Test Engineer	DebeYu	Test Date	April 09, 2024

TEST RESULT OF TM1-TM2

Line	Test Voltage	Polarity	Result (Pass/Fail)
L	1KV	+/-	Pass
N	1KV	+/-	Pass
L-N	1KV	+/-	Pass

11. RF COMMON MODE

11.1. Test Configuration

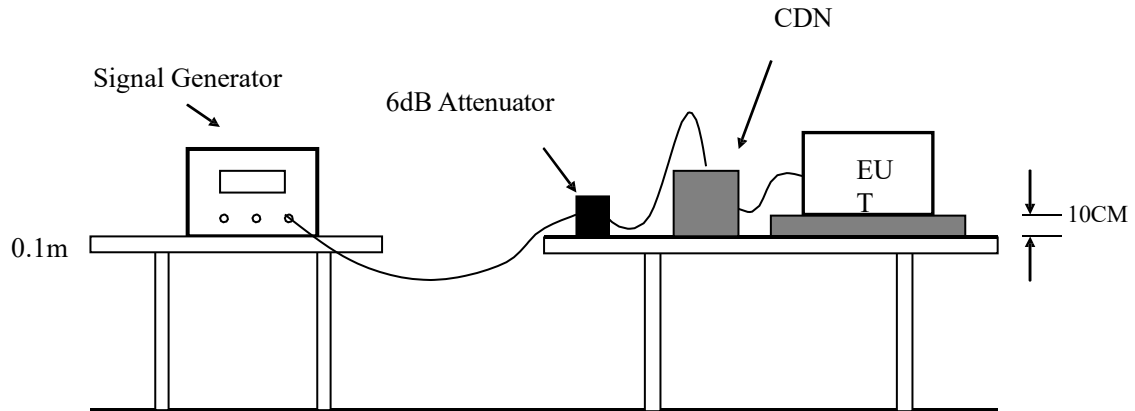

11.2. Test Standard

ETSI EN 301 489-1 V2.2.3/ EN 61000-4-6: 2014+AC:2015

Test level 2 at 3 V (r.m.s.), 0.15 MHz ~ 80 MHz,

Modulation type: AM

Modulation depth: 80%

Modulation signal: 1 kHz

Test level

Level	Voltage Level (r.m.s.) (V)
1	1
2	3
3	10
X	Special

Performance criterion: A

11.3. Test Procedure

11.3.1. Let the EUT work in test mode and test it.

11.3.2. The EUT are placed on an insulating support 0.1 m high above a ground reference plane. CDN (coupling and decoupling device) is placed on the ground plane about 0.3 m from EUT. Cables between CDN and EUT are as short as possible, and their height above the ground reference plane shall be between 30 and 50 mm (where possible).

11.3.3. The disturbance signal described below is injected to EUT through CDN.

11.3.4. The EUT operates within its operational mode(s) under intended climatic conditions after power on.

11.3.5. The frequency range is swept from 150 kHz to 80 MHz using 3V signal level, and with the disturbance signal 80% amplitude modulated with a 1kHz sine wave.

11.3.6. The rate of sweep shall not exceed 1.5×10^{-3} decades/s. Where the frequency is swept incrementally, the step size shall not exceed 1% of the start and thereafter 1% of the preceding frequency value.

11.3.7. Recording the EUT operating situation during compliance testing and decide the EUT immunity criterion.

11.4. Test Data

PASS.

Injected Currents Susceptibility Test Results

Standard	<input type="checkbox"/> IEC 61000-4-6 <input checked="" type="checkbox"/> EN 61000-4-6		
Applicant	Mid Ocean Brands B.V.		
EUT	Bamboo wireless charger	Temperature	24.2°C
M/N	MO6390	Humidity	44.7%
Test Mode	TM2-TM2	Criterion	A
Test Engineer	DebeYu	Test Date	April 09, 2024

TEST RESULT OF TM1-TM2

Frequency Range (MHz)	Injected Position	Strength (Unmodulated)	Result (Pass/Fail)
0.15 ~ 80	AC Mains	3V	Pass

Remark:

1. Modulation Signal:1kHz 80% AM

2. Measurement Equipment :

Simulator: CIT-10 (FRANKONIA)

CDN : CDN-M2 (FRANKONIA)

CDN-M3 (FRANKONIA)

12. SURGES, LINE TO LINE AND LINE TO GROUND

12.1. Test Configuration

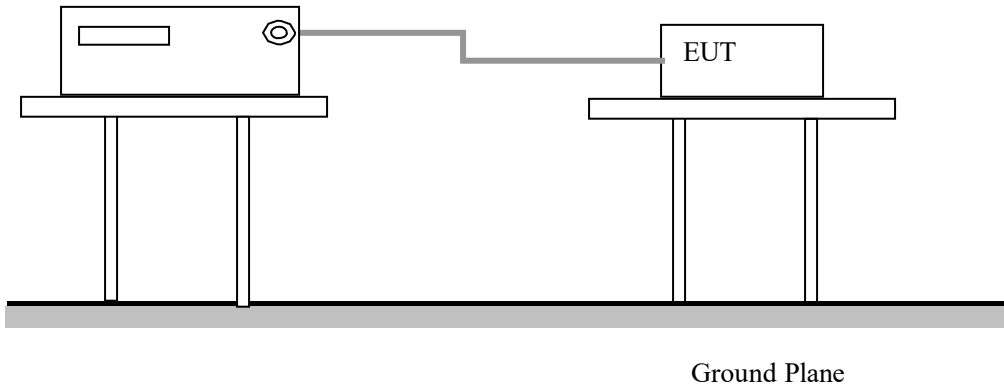

12.2. Test Standard

ETSI EN 301 489-1 V2.2.3 / EN 61000-4-5: 2014

L-N: Test level 2 at 1 kV

L-PE, N-PE Test Level 3 at 2kV

Test Level

Open Circuit Output Test Voltage $\pm 10\%$		
Level	On Power Supply Lines	On I/O (Input/Output) Signal data and control lines
1	0.5 kV	0.25 kV
2	1 kV	0.5 kV
3	2 kV	1 kV
4	4 kV	2 kV
X	Special	Special

Performance criterion: B

12.3. Test Procedure

- 12.3.1. For line to line coupling mode, provide a 0.5 kV 1.2/50us voltage surge (at open-circuit condition).
- 12.3.2. At least 5 positive and 5 negative (polarity) tests with a maximum 1/min repetition rate are conducted during test.
- 12.3.3. Different phase angles are done individually.
- 12.3.4. Record the EUT operating situation during compliance test and decide the EUT immunity criterion for above each test.

12.4. Test Data

Surge Immunity Test Result			
Standard	<input type="checkbox"/> IEC 61000-4-5 <input checked="" type="checkbox"/> EN 61000-4-5		
Applicant	Mid Ocean Brands B.V.		
EUT	Bamboo wireless charger	Temperature	25°C
M/N	MO6390	Humidity	45%
Test Mode	TM1-TM2	Criterion	A
Test Engineer	DebeYu	Test Date	April 09, 2024

TEST RESULT OF TM1-TM2					
Location	Polarity	Phase Angle	Number of Pulse	Pulse Voltage (KV)	Result (Pass/Fail)
L-N	+	0°, 90°, 180°, 270°	5	1.0	Pass
	-	0°, 90°, 180°, 270°	5	1.0	Pass

13. VOLTAGE DIPS/INTERRUPTIONS IMMUNITY TEST

13.1. Test Configuration

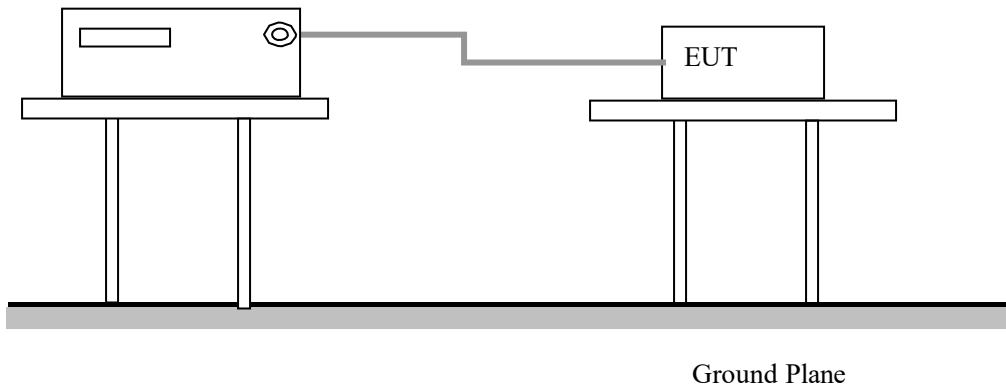

13.2. Test Standard

ETSI EN 301 489-1 V2.2.3/ EN 61000-4-11: 2020
Test levels and Performance Criterion

Test Level

Voltage Reduction %UT	Voltage dips %UT	Duration (in period)
100	0	0.5
100	0	1
30	70	5
Voltage Reduction %UT	Voltage Interruptions %UT	Duration (in period)
100	0	250

Performance criterion: B&C

13.3. Test Procedure

13.3.1. The interruption is introduced at selected phase angles with specified duration.

13.3.2. Record any degradation of performance.

13.4. Test Data

Voltage Dips And Interruptions Test Results			
Standard	<input type="checkbox"/> IEC 61000-4-11 <input checked="" type="checkbox"/> EN 61000-4-11		
Applicant	Mid Ocean Brands B.V.		
EUT	Bamboo wireless charger	Temperature	25°C
M/N	MO6390	Humidity	45%
Test Mode	TM1-TM2	Criterion	A
Test Engineer	DebeYu	Test Date	April 09, 2024

TEST RESULT OF TM1-TM2			
Test Level % U _T	Voltage Dips & Short Interruptions % U _T	Duration (in periods)	Result (Pass/Fail)
0	100	0.5P	Pass
0	100	1P	Pass
70	30	25P	Pass
0	100	250P	Pass

14. LIST OF MEASURING EQUIPMENT

Test Equipment	Manufacturer	Model No.	Serial No.	Last Cal.	Due Date
EMI Test Receiver	ROHDE & SCHWARZ	ESCI	101142	2023-09-18	2024-09-17
10dB Attenuator	SCHWARZBECK	OSPAM236	9729	2023-09-18	2024-09-17
Artificial Mains	ROHDE & SCHWARZ	ENV216	101288	2023-09-18	2024-09-17
EMI Test Software	AUDIX	E3	N/A	2023-09-18	2024-09-17
EMI Test Receiver	ROHDE & SCHWARZ	ESCI	101142	2023-09-18	2024-09-17
Absorbing clamp	ROHDE & SCHWARZ	MDS 21	4033	2023-09-18	2024-09-17
EMI Test Software	AUDIX	E3	N/A	2023-09-18	2024-09-17
EMI Test Receiver	ROHDE & SCHWARZ	ESCI	101142	2023-09-18	2024-09-17
Triple-loop Antenna	EVERFINE	LLA-2	11050003	2023-09-18	2024-09-17
EMI Test Receiver	ROHDE & SCHWARZ	ESPI	101840	2023-09-18	2024-09-17
EMI Test Software	AUDIX	E3	N/A	2023-09-18	2024-09-17
3m Semi Anechoic Chamber	SIDT FRANKONIA	SAC-3M	03CH03-HY	2023-09-18	2024-09-17
EMI Test Receiver	ROHDE & SCHWARZ	ESCI	101142	2023-09-18	2024-09-17
Log per Antenna	SCHWARZBECK	VULB9163	9163-470	2023-09-18	2024-09-17
EMI Test Software	AUDIX	E3	N/A	2023-09-18	2024-09-17
Positioning Controller	MF	MF-7082	/	2023-09-18	2024-09-17
Power Analyzer Test System	Voltech	PM6000	20000670053	2023-09-18	2024-09-17
ESD Simulator	KIKUSUI	KC001311	KES4021	2023-09-03	2024-09-02
SIGNAL GENERATOR	R&S	SMB100A	105942	2023-09-14	2024-09-13
RF Power Amplifier	BONN Elektronik	BLWA0830-160/100/40D	128740	2023-09-14	2024-09-13
Log-periodic Antenna	SCHWARZBECK	STLP9128D	043	2023-09-14	2024-09-13
Power Meter	R&S	102031	16829	2023-09-14	2024-09-13
Electrical fast transient(EFT)generator	3CTEST	EFT-4021	EC0461044	2023-09-18	2024-09-17
Coupling Clamp	3CTEST	EFTC	EC0442098	2023-09-18	2024-09-17
Surge test system	3CTEST	SG5006G	EC5581070	2023-09-18	2024-09-17
Coupling/decoupling network	3CTEST	SGN-5010G	CS5591033	2023-09-18	2024-09-17
Simulator	FRA NKONIA	CIT-10	A126A1195	2023-09-18	2024-09-17
CDN	FRA NKONIA	CDN-M2	5100100100	2023-09-18	2024-09-17
CDN	FRA NKONIA	CDN-M3	0900-11	2023-09-18	2024-09-17
Attenuator	FRA NKONIA	ATT6	0010222A	2023-09-18	2024-09-17
Voltage dips and up generator	3CTEST	VDG-1105G	EC0171014	2023-09-18	2024-09-17

15. PHOTOGRAPHS OF TEST SETUP

Photo of Radiated Emissions Measurement

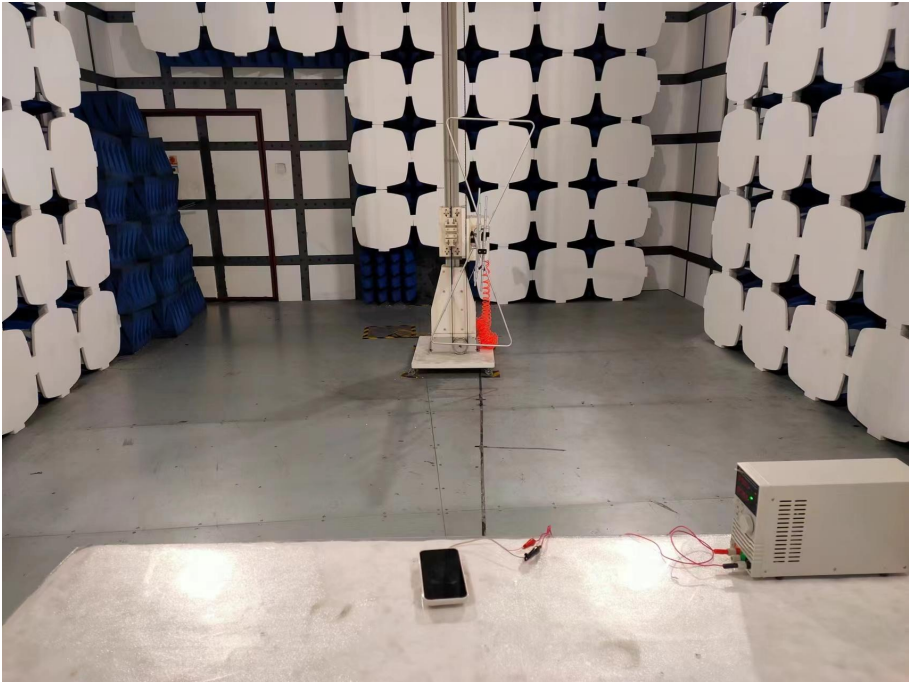

16. EXTERNAL AND INTERNAL PHOTOS OF THE EUT

Appearance photograph of EUT

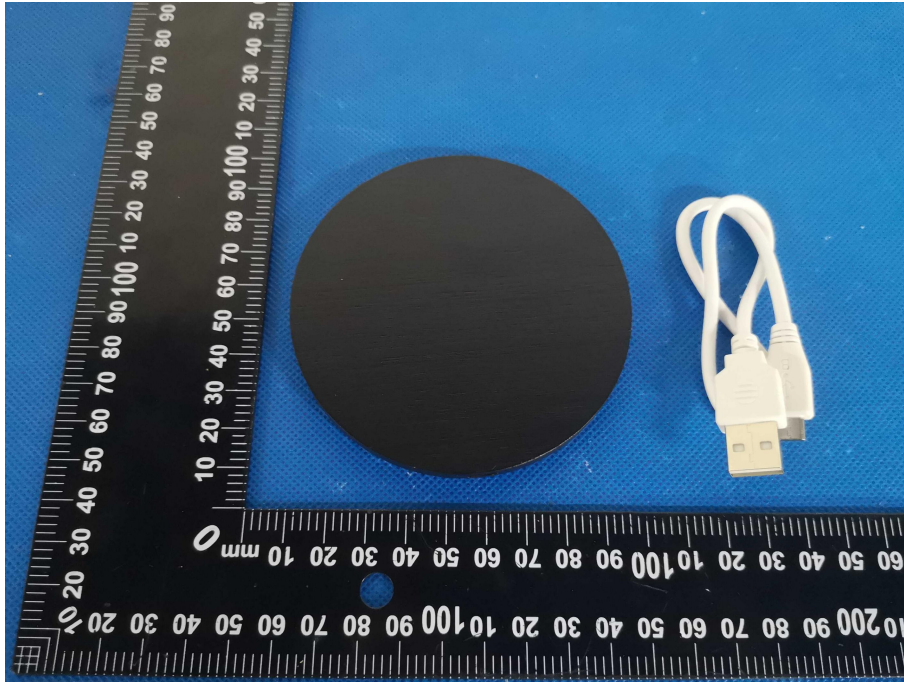

Appearance photograph of EUT

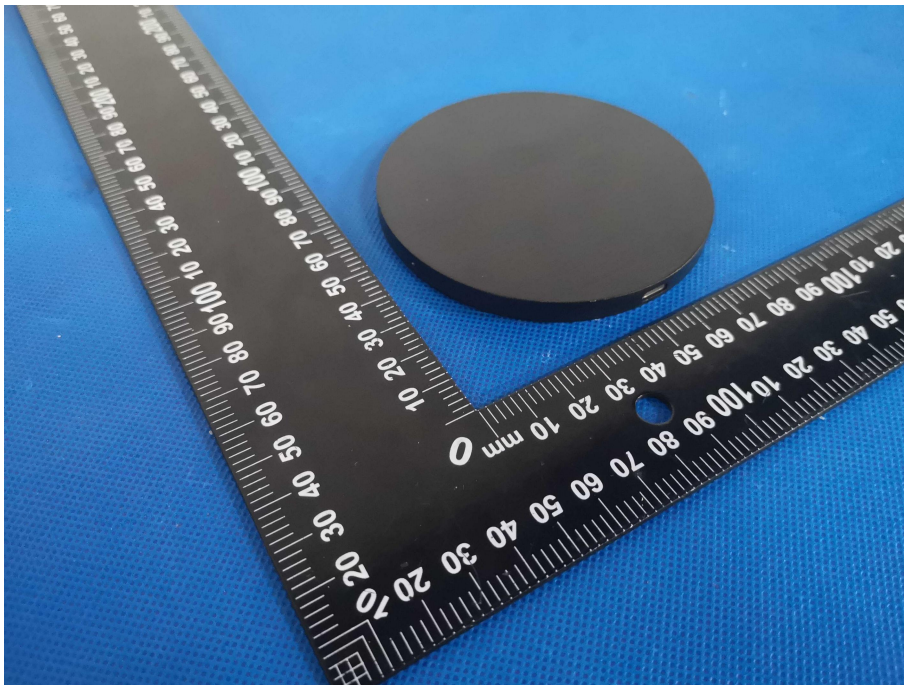

Appearance photograph of EUT

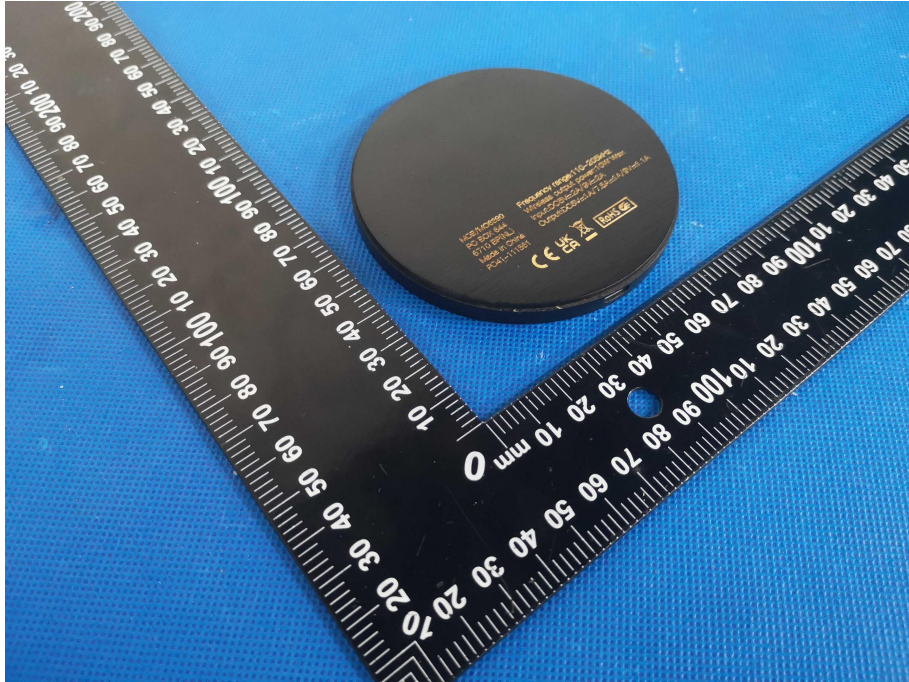

Appearance photograph of EUT

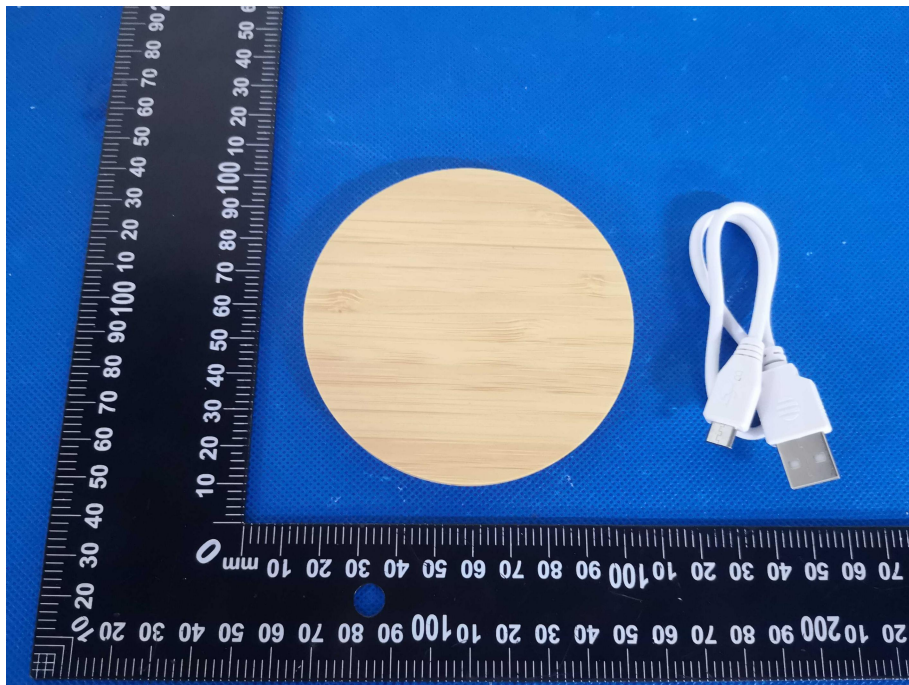

Appearance photograph of EUT

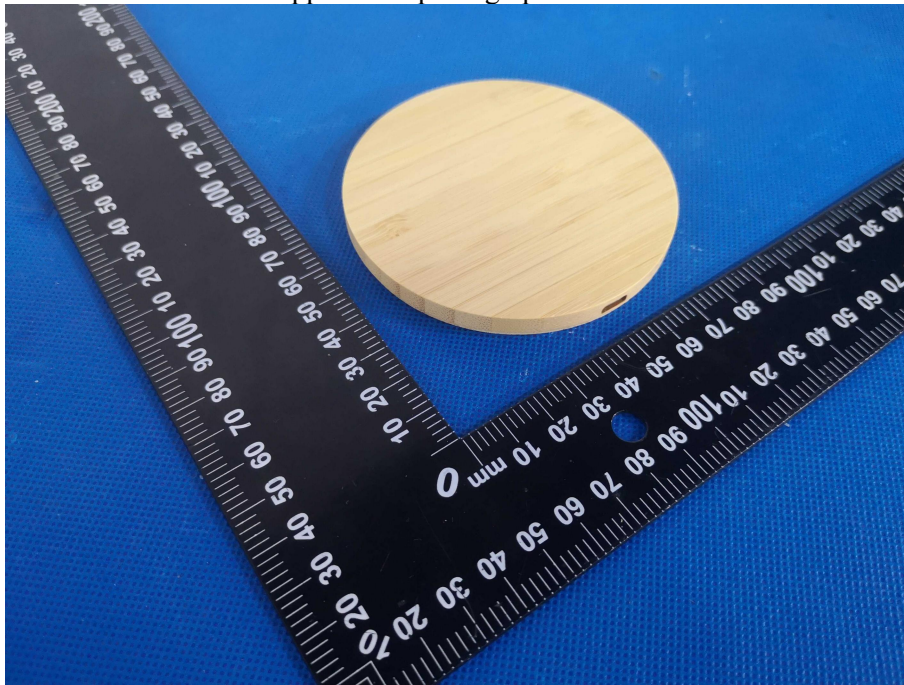

Appearance photograph of EUT

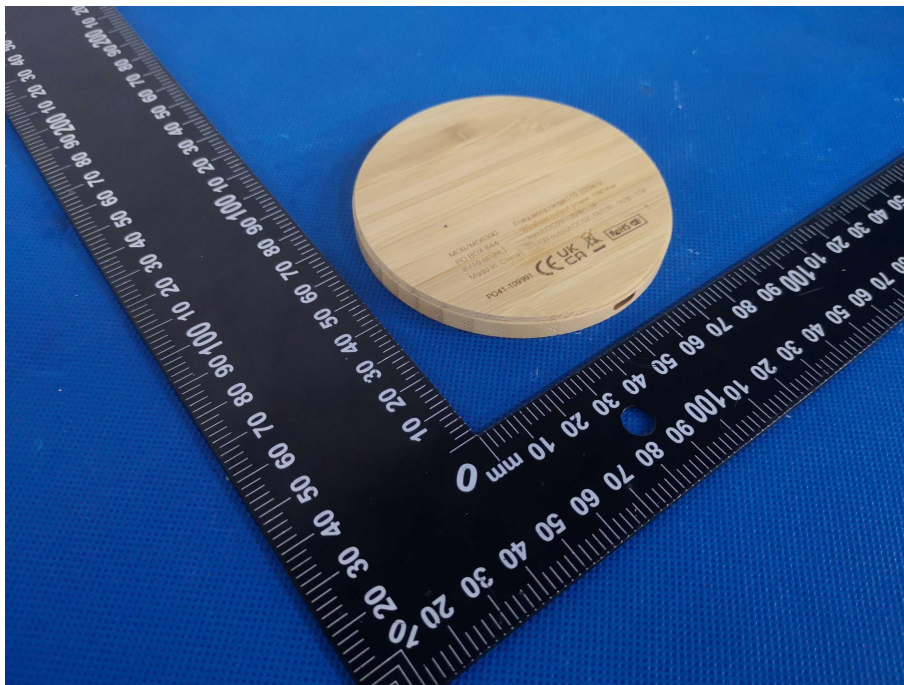

Appearance photograph of EUT

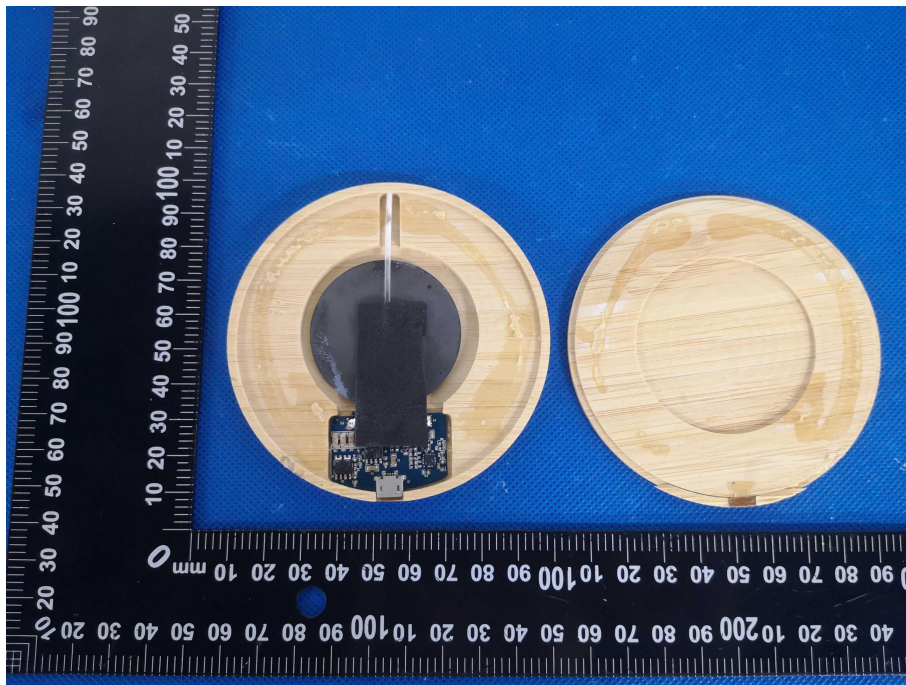

Appearance photograph of EUT

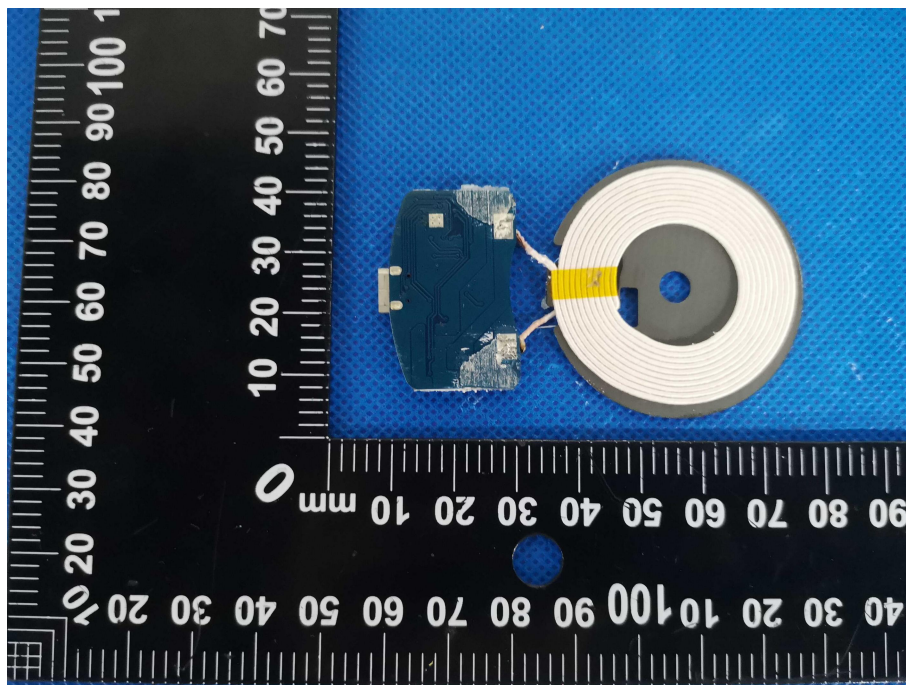

Appearance photograph of EUT

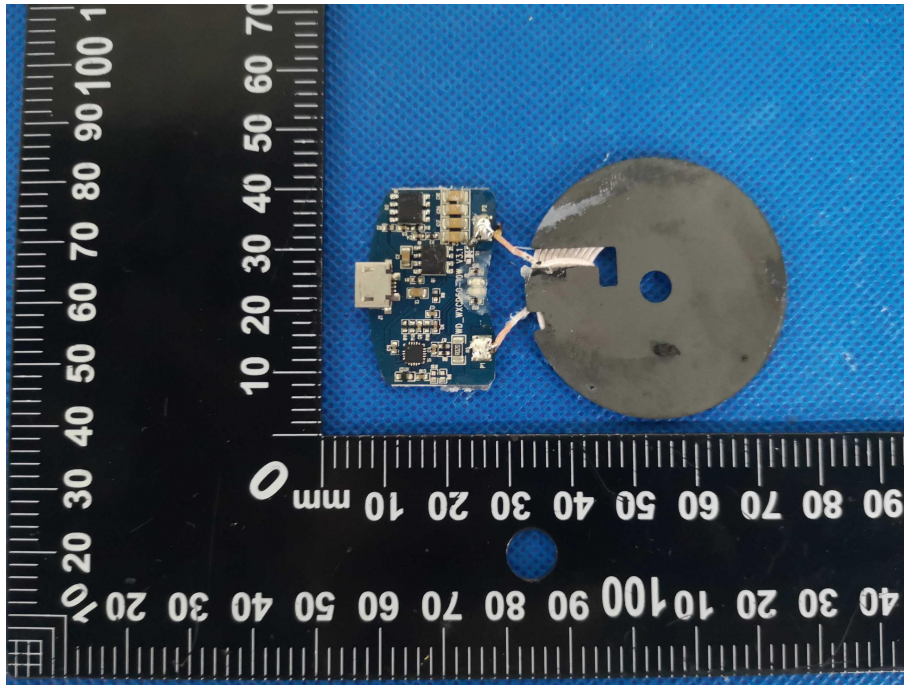

-----THE END OF REPORT-----



EMC REPORT

Prepared For :	Mid Ocean Brands B.V. Add: 7/F., Kings Tower, 111 King Lam Street, Cheung Sha Wan, Kowloon, Hong Kong
Product Name:	Bamboo wireless charger
Trade Mark:	N/A
Model :	MO6390
Prepared By :	Shenzhen SIT Testing Technology Co., Ltd. Add: Room 401, Building A2, The 2nd Industrial Zone of Zhu'ao, Gushu, Xixiang, Bao'an District, Shenzhen, Guangdong, China
Test Date:	April 07, 2024 to April 12, 2024
Date of Report :	April 12, 2024
Report No.:	SIT240328160202ER

Note: This report shall not be reproduced except in full, without the written approval of Shenzhen SIT Testing Technology Co., Ltd. This document may be altered or revised by Shenzhen SIT Testing Technology Co., Ltd, personnel only, and shall be noted in the revision section of the document. The test results in the report only apply to the tested sample.

TABLE OF CONTENTS

1	TEST CERTIFICATION	3
2	TEST RESULT SUMMARY	4
3	EUT DESCRIPTION	5
4	TEST METHODOLOGY	5
4.1.	DECISION OF FINAL TEST MODE	5
4.2.	EUT SYSTEM OPERATION	5
5	SETUP OF EQUIPMENT UNDER TEST	6
5.1.	DESCRIPTION OF SUPPORT UNITS	6
5.2.	CONFIGURATION OF SYSTEM UNDER TEST	6
6	FACILITIES AND ACCREDITATIONS	7
6.1.	FACILITIES	7
6.2.	ACCREDITATIONS	7
6.3.	MEASUREMENT UNCERTAINTY	7
7	EMISSION TEST	8
7.1.	CONDUCTED EMISSION MEASUREMENT	8
7.2.	RADIATED EMISSION MEASUREMENT	11
8	IMMUNITY TEST	16
8.1.	GENERAL DESCRIPTION	16
8.2.	GENERAL PERFORMANCE CRITERIA DESCRIPTION	17
8.3.	ELECTROSTATIC DISCHARGE (ESD)	18
8.4.	RADIATED, RADIO-FREQUENCY, ELECTROMAGNETIC FIELD (RS)	22
8.5.	ELECTRICAL FAST TRANSIENT (EFT)	25
8.6.	SURGE IMMUNITY TEST	28
8.7.	CONDUCTED RADIO FREQUENCY DISTURBANCES (CS)	31
8.8.	POWER FREQUENCY MAGNETIC FIELD	35
8.9.	VOLTAGE DIP & VOLTAGE INTERRUPTIONS	38
9	PHOTOGRAPHS OF THE TEST CONFIGURATION	40
10	PHOTOGRAPHS OF EUT	41

1 TEST CERTIFICATION

Product: Bamboo wireless charger

Model: MO6390

Applicant: Mid Ocean Brands B.V.

Add: 7/F., Kings Tower, 111 King Lam Street, Cheung Sha Wan, Kowloon, Hong Kong

Manufacturer: 114628

Trade Mark: N/A

Tested: April 07, 2024 to April 12, 2024

Test Voltage: DC 5V

Applicable Standards: EN 55032:2015+A1:2020

EN IEC 61000-3-2:2019+A1:2021

EN 61000-3-3:2013+A2:2021

EN 55035:2017+A11:2020

The above equipment has been tested by Shenzhen SIT Testing Technology Co., Ltd., and found compliance with the requirements set forth in the technical standards mentioned above. The results of testing in this report apply only to the product/system, which was tested. Other similar equipment will not necessarily produce the same results due to production tolerance and measurement uncertainties.

Prepared by :

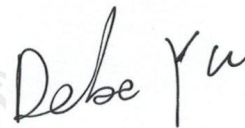

Assistant

Reviewer :



Supervisor

Approved & Authorized Signer :



2 TEST RESULT SUMMARY

EMISSION			
Standard	Item	Result	Remarks
EN 55032:2015+A1:2020	Conducted (Main Port)	N/A	N/A
	Radiated	PASS	Meet Class B limit
EN IEC 61000-3-2:2019+A1:2021	Harmonic current emissions	N/A	N/A
EN 61000-3-3:2013+A2:2021	Voltage fluctuations & flicker	N/A	N/A

IMMUNITY 【EN55035:2017+A11:2020】			
Standard	Item	Result	Remarks
EN 61000-4-2:2009	ESD	PASS	Meets the requirements of Performance Criterion B
EN IEC 61000-4-3:2020	RS	PASS	Meets the requirements of Performance Criterion A
EN 61000-4-4:2012	EFT	N/A	Meets the requirements of Performance Criterion B
EN 61000-4-5:2014+A1:2017	Surge	N/A	Meets the requirements of Performance Criterion B
EN 61000-4-6:2014+AC:2015	CS	N/A	Meets the requirements of Performance Criterion A
EN 61000-4-8: 2010	PFMF	N/A	Meets the requirements of Performance Criterion A
EN IEC 61000-4-11:2020	Voltage dips & voltage variations	N/A	Meets the requirements of Voltage dips: 1) >95% reduction performance Criterion B 2) 30% reduction performance Criterion C Voltage variations: 1)>95% reduction performance Criterion C

- Note:**
1. The test result judgment is decided by the limit of test standard
 2. The information of measurement uncertainty is available upon the customer's request.

3 EUT DESCRIPTION

Product	Bamboo wireless charger
Model	MO6390
Trade Mark	N/A
Applicant	Mid Ocean Brands B.V.
Housing material	Bamboo
EUT Type	<input checked="" type="checkbox"/> Engineering Sample. <input type="checkbox"/> Product Sample, <input type="checkbox"/> Mass Product Sample.
Serial Number	N/A
Power Rating	Input: 5V $\overline{\text{---}}$ 2A, 9V $\overline{\text{---}}$ 2A Output: 5V $\overline{\text{---}}$ 1A, 7.5V $\overline{\text{---}}$ 1A, 9V $\overline{\text{---}}$ 1.1A

4 TEST METHODOLOGY

4.1. DECISION OF FINAL TEST MODE

The EUT was tested together with the thereafter additional components, and a configuration, which produced the worst emission levels, was selected and recorded in this report.

The following test mode(s) were scanned during the preliminary test:

Pre-Test Mode		
Mode Emission	Radiated Emission	Mode1 : Discharging

After the preliminary scan, the following test mode was found to produce the highest emission level.

The Worst Test Mode		
Mode Emission	Radiated Emission	Mode1 : Discharging

4.2. EUT SYSTEM OPERATION

1. Set up EUT with the support equipments.
2. Make sure the EUT work normally during the test.

5 SETUP OF EQUIPMENT UNDER TEST

5.1. DESCRIPTION OF SUPPORT UNITS

The EUT has been tested as an independent unit together with other necessary accessories or support units. The following support units or accessories were used to form a representative test configuration during the tests.

Note:

- 1) All the equipment/cables were placed in the worst-case configuration to maximize the emission during the test.
- 2) Grounding was established in accordance with the manufacturer's requirements and conditions for the intended use.

5.2. CONFIGURATION OF SYSTEM UNDER TEST



(EUT: Bamboo wireless charger)

6 FACILITIES AND ACCREDITATIONS

6.1. FACILITIES

All measurement facilities used to collect the measurement data are located at SIT LAB.

The sites are constructed in conformance with the requirements of ANSI C63.4 and CISPR Publication 22. All receiving equipment conforms to CISPR Publication 16-1, "Radio Interference Measuring Apparatus and Measurement Methods."

6.2. ACCREDITATIONS

Our laboratories are accredited and approved by the following approval agencies according to ISO/IEC 17025.

Copies of granted accreditation certificates are available for downloading from our web site, www.sit-cert.com

6.3. MEASUREMENT UNCERTAINTY

Where relevant, the following measurement uncertainty levels have been estimated for tests performed on the EUT as specified in CISPR 16-4-2:

Measurement	Frequency	Uncertainty	
Conducted emissions	9kHz~30MHz	+/- 3.59dB	
Radiated emissions	Horizontal	30MHz ~ 200MHz	+/- 4.77dB
		200MHz ~1000MHz	+/- 4.93dB
	Vertical	30MHz ~ 200MHz	+/- 5.04dB
		200MHz ~1000MHz	+/- 4.93dB

This uncertainty represents an expanded uncertainty expressed at approximately the 95% confidence level using a coverage factor of $k=2$.

7 EMISSION TEST

7.1. CONDUCTED EMISSION MEASUREMENT

7.1.1. LIMITS

FREQUENCY (MHz)	Class B (dBuV)	
	Quasi-peak	Average
0.15 - 0.5	66 - 56	56 - 46
0.50 - 5.0	56	46
5.0 - 30.0	60	50

NOTE:

- (1) The lower limit shall apply at the transition frequencies.
- (2) The limit decreases in line with the logarithm of the frequency in the range of 0.15 to 0.50 MHz.
- (3) All emanations from a class A/B digital device or system, including any network of conductors and apparatus connected thereto, shall not exceed the level of field strengths specified above.

7.1.2. TEST INSTRUMENTS

Conducted Emission Shielding Room Test Site (743)				
Name of Equipment	Manufacturer	Model	Serial Number	Calibration Due
EMI Test Receiver	R&S	ESCI	100005	09/14/2024
LISN	AFJ	LS16	16010222119	09/19/2024
LISN(EUT)	Mestec	AN3016	04/10040	09/18/2024

- NOTE:**
1. The calibration interval of the above test instruments is 12 months and the calibrations are traceable to international system unit (SI).
 2. N.C.R = No Calibration Request.

7.1.3. TEST PROCEDURES

Procedure of Preliminary Test

The EUT and Support equipment, if needed, was set up as per the test configuration to simulate typical usage per the user's manual. When the EUT is a tabletop system, a wooden table with a height of 0.8 meters is used and is placed on the ground plane as per EN55032 (see Test Facility for the dimensions of the ground plane used). When the EUT is a floor standing equipment, it is placed on the ground plane, which has a 3-12 mm non-conductive covering to insulate the EUT from the ground plane.

All I/O cables were positioned to simulate typical actual usage as per EN55032.

The EUT test program was started. Emissions were measured on each current carrying line of the EUT using an EMI Test Receiver connected to the LISN powering the EUT.

The Receiver scanned from 150 kHz to 30MHz for emissions in each of the test modes.

During the above scans, the emissions were maximized by cable manipulation.

The test mode(s) described in Item 3.1 were scanned during the preliminary test.

After the preliminary scan, we found the test mode described in Item 3.1 producing the highest emission level.

The EUT configuration and cable configuration of the above highest emission levels were recorded for reference of the final test.

Procedure of Final Test

EUT and support equipment were set up on the test bench as per the configuration with highest emission level in the preliminary test.

A scan was taken on both power lines, Line 1 and Line 2, recording at least the six highest emissions. Emission frequency and amplitude were recorded into a computer in which correction factors were used to calculate the emission level and compare reading to the applicable limit.

The test data of the worst-case condition(s) was recorded.

7.1.4. TEST SETUP

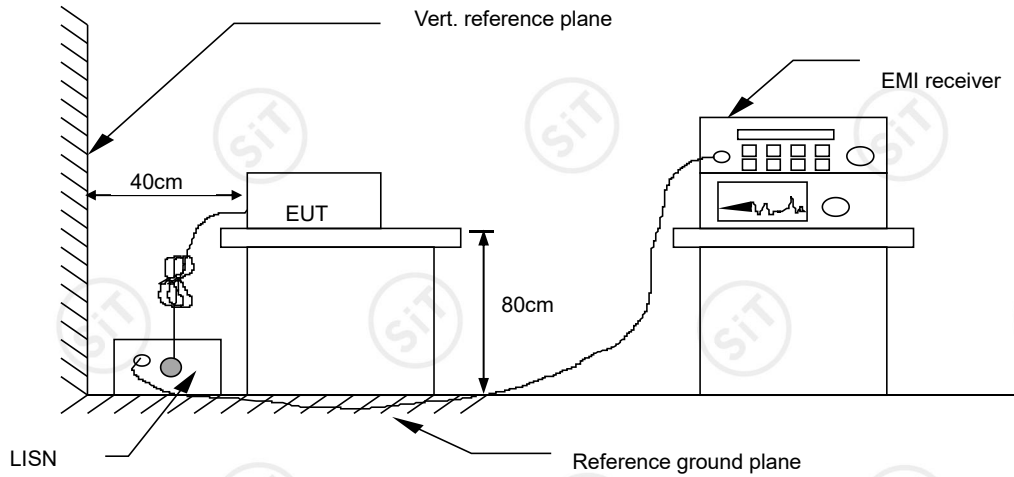

For the actual test configuration, please refer to the related item – Photographs of the Test Configuration.

7.1.5. TEST RESULTS

Model No.	MO6390	6dB Bandwidth	10 KHz
Environmental Conditions	26°C, 60% RH	Test Mode	N/A
Detector Function	Peak / Quasi-peak/AV	Test Result	N/A
Test By	DebeYu		

NOTE:

L1 = Line One (Live Line) / L2 = Line Two (Neutral Line).

“---” denotes the emission level was or more than 2dB below the Average limit, so no re-check anymore.

Freq. = Emission frequency in MHz

Reading level (dBuV) = Receiver reading

Corr. Factor (dB) = Attenuator factor + Cable loss

Level (dBuV) = Reading level (dBuV) + Corr. Factor (dB)

Limit (dBuV) = Limit stated in standard

Margin (dB) = Level (dBuV) – Limits (dBuV)

Q.P.=Quasi-Peak

7.2. RADIATED EMISSION MEASUREMENT

7.2.1. LIMITS

FREQUENCY (MHz)	dBuV/m (At 3m)
	Limit
30 ~ 230	40
230 ~ 1000	47

NOTE: (1) The lower limit shall apply at the transition frequencies.
 (2) Emission level (dBuV/m) = 20 log Emission level (uV/m).

7.2.2. TEST INSTRUMENTS

Radiated Emission Test Site (966)				
Name of Equipment	Manufacturer	Model	Serial Number	Calibration Due
EMI Test Receiver	R&S	ESCI	100005	09/14/2024
Spectrum Analyzer	R&S	FSU	100114	09/17/2024
Pre Amplifier	H.P.	HP8447E	2945A02715	09/14/2024
Bilog Antenna	SUNOL Sciences	JB3	A021907	09/17/2024
Cable	TIME MICROWAVE	LMR-400	N-TYPE04	09/19/2024
System-Controller	CCS	N/A	N/A	N.C.R
Turn Table	CCS	N/A	N/A	N.C.R
Antenna Tower	CCS	N/A	N/A	N.C.R

NOTE: 1. The calibration interval of the above test instruments is 12 months and the calibrations are traceable to international system unit (SI).
 2. N.C.R = No Calibration Request.

7.2.3. TEST PROCEDURE

Procedure of Preliminary Test

The equipment was set up as per the test configuration to simulate typical usage per the user's manual. When the EUT is a tabletop system, a wooden turntable with a height of 0.8 meters is used which is placed on the ground plane. When the EUT is a floor standing equipment, it is placed on the ground plane which has a 3-12 mm non-conductive covering to insulate the EUT from the ground plane.

Support equipment, if needed, was placed as per EN55032.

All I/O cables were positioned to simulate typical usage as per EN55032.

Mains cables, telephone lines or other connections to auxiliary equipment located outside the test are shall drape to the floor, be fitted with ferrite clamps or ferrite tubes placed on the floor at the point where the cable reaches the floor and then routed to the place where they leave the turntable. No extension cords shall be used to mains receptacle.

The antenna was placed at 3 meter away from the EUT as stated in EN 55032. The antenna connected to the Spectrum Analyzer via a cable and at times a pre-amplifier would be used.

The Analyzer / Receiver quickly scanned from 30MHz to 1000MHz. The EUT test program was started. Emissions were scanned and measured rotating the EUT to 360 degrees and positioning the antenna 1 to 4 meters above the ground plane, in both the vertical and the horizontal polarization, to maximize the emission reading level.

The test mode(s) described in Item 3.1 were scanned during the preliminary test:

After the preliminary scan, we found the test mode described in Item 3.1 producing the highest emission level. The EUT and cable configuration, antenna position, polarization and turntable position of the above highest emission level were recorded for the final test.

Procedure of Final Test

EUT and support equipment were set up on the turntable as per the configuration with highest emission level in the preliminary test.

The Analyzer / Receiver scanned from 30MHz to 1000MHz. Emissions were scanned and measured rotating the EUT to 360 degrees, varying cable placement and positioning the antenna 1 to 4 meters above the ground plane, in both the vertical and the horizontal polarization, to maximize the emission reading level.

Recorded at least the six highest emissions. Emission frequency, amplitude, antenna position, polarization and turntable position were recorded into a computer in which correction factors were used to calculate the emission level and compare reading to the applicable limit and only Q.P. reading is presented.

The test data of the worst-case condition(s) was recorded.

7.2.4. TEST SETUP

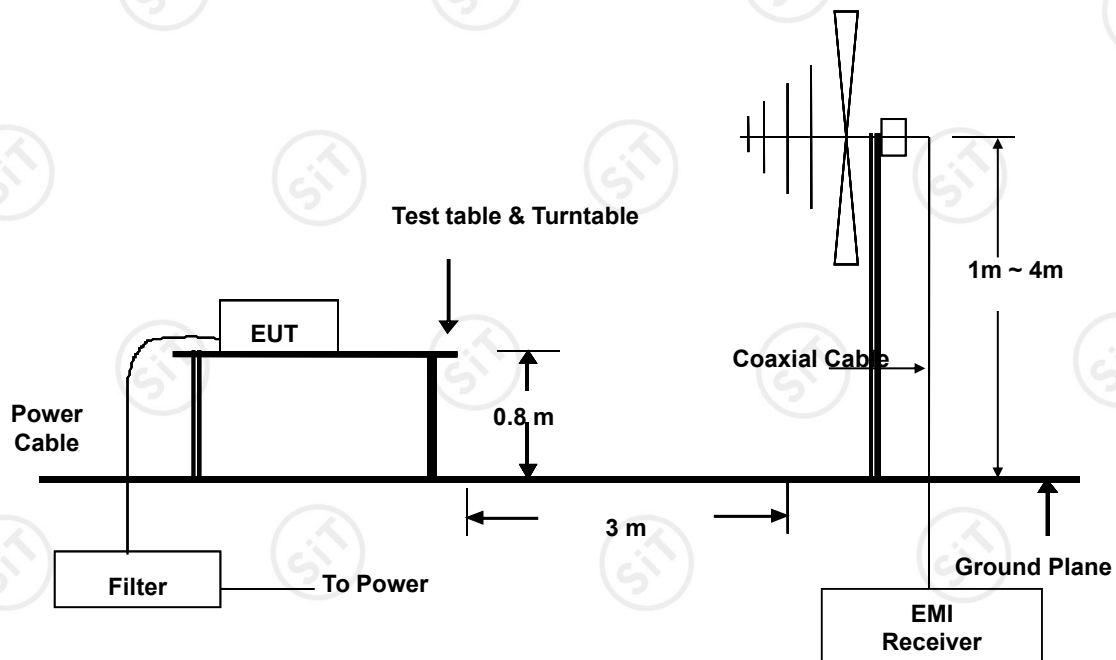

For the actual test configuration, please refer to the related item – Photographs of the Test Configuration

7.2.5 TEST RESULTS

Model No.	MO6390	Test Mode	Discharging
Environmental Conditions	26°C, 60% RH	6dB Bandwidth	120 KHz
Antenna Pole	Vertical / Horizontal	Antenna Distance	3m
Detector Function	Peak / Quasi-peak	Tested by	DebeYu

Freq. = Emission frequency in MHz

Reading level (dBuV) = Receiver reading

Corr. Factor (dB) = Antenna factor + Cable loss

Measurement (dBuV) = Reading level (dBuV) + Corr. Factor (dB)

Limit (dBuV) = Limit stated in standard

Margin (dB) = Measurement (dBuV) – Limits (dBuV)

Radiated Emission Measurement



Site LAB

Limit: EN 55032 CLASS B

EUT: Bamboo wireless charger

M/N: MO6390

Mode:

Note:

Polarization: **Horizontal**

Temperature:

Power:

Humidity: %

Distance: 3m

No.	Mk.	Freq. MHz	Reading Level dBuV	Correct Factor dB	Measure- ment dBuV/m	Limit dB/m	Over dB	Detector	Antenna Height cm	Table Degree degree	Comment
1		40.4172	38.80	-10.22	28.58	40.00	-11.42	peak			
2		47.9940	37.78	-10.92	26.86	40.00	-13.14	peak			
3		63.0916	42.22	-12.14	30.08	40.00	-9.92	peak			
4		98.8326	42.24	-14.92	27.32	40.00	-12.68	peak			
5		154.2786	41.04	-10.59	30.45	40.00	-9.55	peak			
6	*	172.5988	46.68	-11.44	35.24	40.00	-4.76	peak			

Radiated Emission Measurement

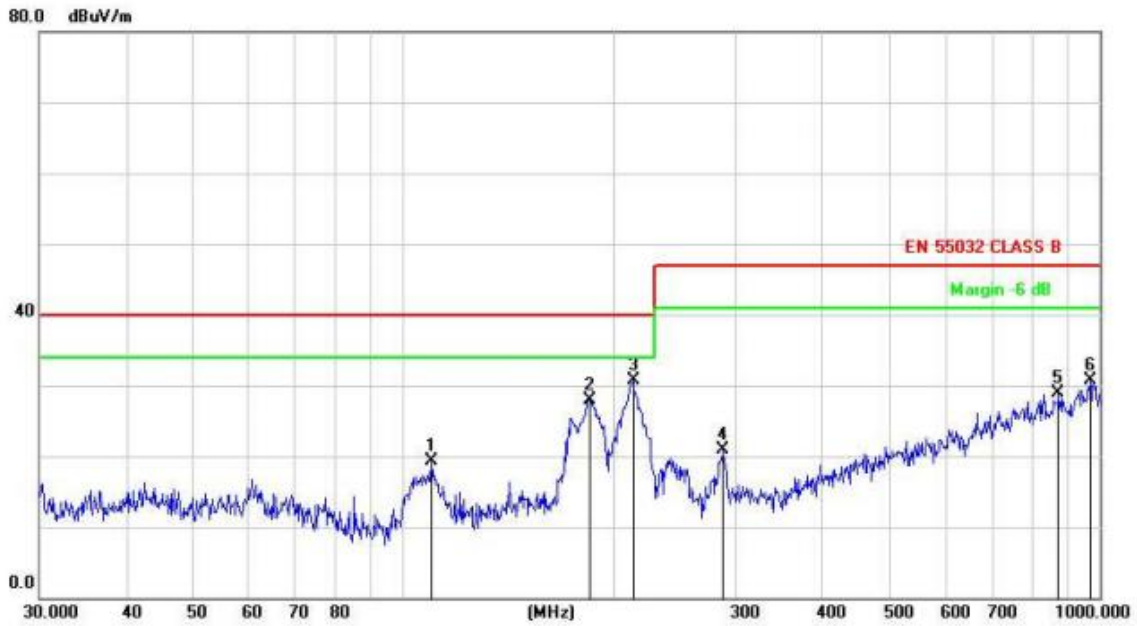

Site LAB

Polarization: **Vertical**

Temperature:

Limit: EN 55032 CLASS B

Power:

Humidity: %

EUT: Bamboo wireless charger

Distance: 3m

M/N: MO6390

Mode:

Note:

No.	Mk.	Freq. MHz	Reading Level dBuV	Correct Factor dB	Measure- ment dBuV/m	Limit dB/m	Over dB	Antenna Height cm	Table Degree degree	Comment
1		109.7960	33.40	-14.09	19.31	40.00	-20.69	peak		
2		185.1379	40.99	-13.08	27.91	40.00	-12.09	peak		
3	*	213.7634	43.95	-13.32	30.63	40.00	-9.37	peak		
4		287.9904	31.81	-11.00	20.81	47.00	-26.19	peak		
5		872.1832	27.57	1.25	28.82	47.00	-18.18	peak		
6		968.9338	27.17	3.51	30.68	47.00	-16.32	peak		

8 IMMUNITY TEST

8.1. GENERAL DESCRIPTION

Product Standard	EN55035:2017+A11:2020	
	Test Type	Minimum Requirement
Basic Standard, Specification, and Performance Criterion required	EN 61000-4-2	Electrostatic Discharge – ESD: 8kV air discharge, 4kV Contact discharge, Performance Criterion B
	EN IEC 61000-4-3	Radio-Frequency Electromagnetic Field Susceptibility Test – RS: 80 ~1000 MHz, 3V/m, 80% AM(1kHz), Performance Criterion A
	EN 61000-4-4	Electrical Fast Transient/Burst - EFT, Power line: 1kV, Signal line: 0.5kV, Performance Criterion B
	EN 61000-4-5	Surge Immunity Test: 1.2/50 us Open Circuit Voltage, 8 /20 us Short Circuit Current, Power Port ~ Line to line: 1kV, Line to ground: 2kV Signal Port ~ Lines to ground : 1kV Performance Criterion B
	EN 61000-4-6	Conducted Radio Frequency Disturbances Test –CS: 0.15 ~ 80 MHz, 3Vrms, 80% AM, 1kHz, Performance Criterion A
	EN 61000-4-8	Power frequency magnetic field immunity test 50 Hz, 1A/m Performance Criterion A
	EN IEC 61000-4-11	Voltage Dips: i) >95% reduction for 0.5 period, Performance Criterion B ii) 30% reduction for 25 period, Performance Criterion C Voltage Interruptions: >95% reduction for 250 period Performance Criterion C

8.2. GENERAL PERFORMANCE CRITERIA DESCRIPTION

<p>Criteria A:</p>	<p>The apparatus shell continues to operate as intended without operator intervention. No degradation of performance or loss of function is allowed below a performance level specified by the manufacturer, when the apparatus is used as intended. The performance level may be replaced by a permissible loss of performance. If the manufacturer does not specify the minimum performance level or the permissible performance loss, then either of these may be derived from the product description and documentation, and by what the user may reasonably expect from the equipment if used as intended.</p>
<p>Criteria B:</p>	<p>After test, the apparatus shell continues to operate as intended without operator intervention. No degradation of performance or loss of function is allowed, after the application of the phenomenon below a performance level specified by the manufacturer, when the apparatus is used as intended. The performance level may be replaced by a permissible loss of performance.</p> <p>During the test, degradation of performance is however allowed. However, no change of operating state if stored data is allowed to persist after the test. If the manufacturer does not specify the minimum performance level or the permissible performance loss, then either of these may be derived from the product description and documentation, and by what the user may reasonably expect from the equipment if used as intended.</p>
<p>Criteria C:</p>	<p>Temporary loss of function is allowed, provided the functions is self-recoverable or can be restored by the operation of controls by the user in accordance with the manufacturer instructions.</p> <p>Functions, and/or information stored in non-volatile memory, or protected by a battery backup, shall not be lost.</p>

8.3. ELECTROSTATIC DISCHARGE (ESD)

8.3.1. TEST SPECIFICATION

Basic Standard:	EN 61000-4-2
Discharge Impedance:	330 ohm
Discharging Capacity:	150pF
Discharge Voltage:	Air Discharge: 8 kV (Direct) Contact Discharge: 4 kV (Direct/Indirect)
Polarity:	Positive & Negative
Number of Discharge:	Minimum 25 times at each test point
Discharge Mode:	1 time/s
Performance Criterion:	B

8.3.2. TEST INSTRUMENT

IMMUNITY SHIELDED ROOM				
Name of Equipment	Manufacturer	Model	Serial Number	Calibration Due
ESD 2000	EMC PARTNER	ESD2000	182	09/09/2024

NOTE: The calibration interval of the above test instruments is 12 months and the calibrations are traceable to international system unit (SI).

8.3.3. TEST PROCEDURE

The discharges shall be applied in two ways:

a) Contact discharges to the conductive surfaces and coupling planes:

The EUT shall be exposed to at least 200 discharges, 100 each at negative and positive polarity, at a minimum of four test points. One of the test points shall be subjected to at least 50 indirect discharges to the center of the front edge of the **Horizontal Coupling Plane (HCP)**. The remaining three test points shall each receive at least 50 direct contact discharges. If no direct contact test points are available, then at least 200 indirect discharges shall be applied in the indirect mode. Test shall be performed at a maximum repetition rate of one discharge per second.

b) Air discharges at slots and apertures and insulating surfaces:

On those parts of the EUT where it is not possible to perform contact discharge testing, the equipment should be investigated to identify user accessible points where breakdown may occur. Such points are tested using the air discharge method. This investigation should be restricted to those area normally handled by the user. A minimum of 10 single air discharges shall be applied to the selected test point for each such area.

The basic test procedure was in accordance with IEC 61000-4-2:

- a) The EUT was located 0.1 m minimum from all side of the **HCP** (dimensions 1.6m x 0.8m).
- b) The support units were located another table 30 cm away from the EUT, but direct support unit was/were located at same location as EUT on the HCP and keep at a distance of 10 cm with EUT.
- c) The time interval between two successive single discharges was at least 1 second.
- d) Contact discharges were applied to the non-insulating coating, with the pointed tip of the generator penetrating the coating and contacting the conducting substrate.
- e) Air discharges were applied with the round discharge tip of the discharge electrode approaching the EUT as fast as possible (without causing mechanical damage) to touch the EUT. After each discharge, the ESD generator was removed from the EUT and re-triggered for a new single discharge. The test was repeated until all discharges were complete.
- f) At least ten single discharges (in the most sensitive polarity) were applied at the front edge of each **HCP** opposite the center point of each unit of the EUT and 0.1 meters from the front of the EUT. The long axis of the discharge electrode was in the plane of the **HCP** and perpendicular to its front edge during the discharge.
- g) At least ten single discharges (in the most sensitive polarity) were applied to the center of one vertical edge of the **Vertical Coupling Plane (VCP)** in sufficiently different positions that the four faces of the EUT were completely illuminated. The **VCP** (dimensions 0.5m x 0.5m) was placed vertically to and 0.1 meters from the EUT.

8.3.4. TEST SETUP

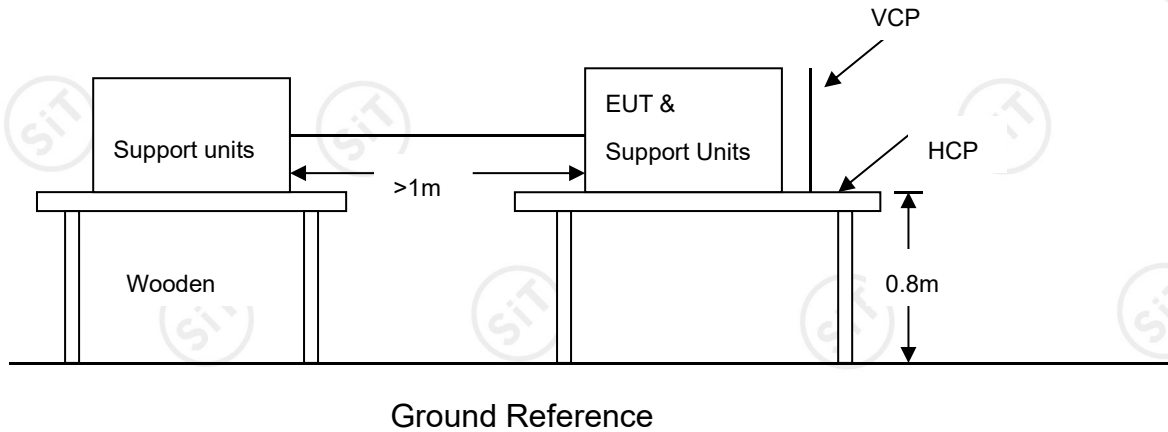

For the actual test configuration, please refer to the related item – Photographs of the Test Configuration.

NOTE:

TABLE-TOP EQUIPMENT

The configuration consisted of a wooden table 0.8 meters high standing on the **Ground Reference Plane**. The **GRP** consisted of a sheet of aluminum at least 0.25mm thick, and 2.5 meters square connected to the protective grounding system. A **Horizontal Coupling Plane** (1.6m x 0.8m) was placed on the table and attached to the **GRP** by means of a cable with 940k total impedance. The equipment under test, was installed in a representative system as described in section 7 of EN 61000-4-2, and its cables were placed on the **HCP** and isolated by an insulating support of 0.5mm thickness. A distance of 1-meter minimum was provided between the EUT and the walls of the laboratory and any other metallic structure.

FLOOR-STANDING EQUIPMENT

The equipment under test was installed in a representative system as described in section 7 of IEC 61000-4-2, and its cables were isolated from the Ground Reference Plane by an insulating support of 0.1-meter thickness. The GRP consisted of a sheet of aluminum that is at least 0.25mm thick, and 2.5 meters square connected to the protective grounding system and extended at least 0.5 meters from the EUT on all sides.

8.3.5. TEST RESULTS

Temperature:	25°C	Humidity	55% RH
Pressure	996mbar	Test result	Pass
Test mode	Discharging	Test By	DebeYu

Air Discharge						
Test locations	Test Levels	Results				
		± 8 kV	Pass	Fail	Performance Criterion	Observation
Button and Top	2Points	<input checked="" type="checkbox"/>	<input checked="" type="checkbox"/>	<input type="checkbox"/>	B	Note <input type="checkbox"/> 1 <input checked="" type="checkbox"/> 2

Contact Discharge						
Test Points	Test Levels	Results				
		± 4 kV	Pass	Fail	Performance Criterion	Observation
HCP	2Points	<input checked="" type="checkbox"/>	<input checked="" type="checkbox"/>	<input type="checkbox"/>	B	Note <input type="checkbox"/> 1 <input checked="" type="checkbox"/> 2
VCP	2Points	<input checked="" type="checkbox"/>	<input checked="" type="checkbox"/>	<input type="checkbox"/>	B	Note <input type="checkbox"/> 1 <input checked="" type="checkbox"/> 2

NOTE: 1. There was no change compared with initial operation during the test.
 2. The loss of function of the EUT during the test and it was recovered by itself operation after the test.

8.4. RADIATED, RADIO-FREQUENCY, ELECTROMAGNETIC FIELD (RS)

Basic Standard:	EN IEC 61000-4-3
Frequency Range:	80 MHz ~1000 MHz,
Field Strength:	3 V/m
Modulation:	1kHz Sine Wave, 80%, AM Modulation
Frequency Step:	1 % of preceding frequency value
Polarity of Antenna:	Horizontal and Vertical
Test Distance:	3 m
Antenna Height:	1.5m
Performance Criterion:	A

8.4.2. TEST INSTRUMENT

743 RS Chamber				
Name of Equipment	Manufacturer	Model	Serial Number	Calibration Due
Signal Generator	Maconi	2022D	119246/003	09/19/2024
Power Amplifier	M2S	A00181-1000	9801-112	09/19/2024
Power Amplifier	M2S	AC8113/ 800-250A	9801-179	09/19/2024
Power Antenna	SCHAFFNER	CBL6140A	1204	09/19/2024

NOTE: 1. The calibration interval of the above test instruments is 12 months and the calibrations are traceable to international system unit (SI).
 2. N.C.R.= No Calibration required

8.4.3. TEST PROCEDURE

The test procedure was in accordance with EN IEC 61000-4-3.

- a) The testing was performed in a fully anechoic chamber. The transmit antenna was located at a distance of 3 meters from the EUT.
- b) The frequency range is swept from 80 MHz to 1000 MHz, with the signal 80% amplitude modulated with a 1 kHz sine-wave. The rate of sweep did not exceed 1.5×10^{-3} decade/s, where the frequency range is swept incrementally, the step size was 1% of preceding frequency value.
- c) The dwell time at each frequency shall be not less than the time necessary for the EUT to be able to respond.
- d) The test was performed with the EUT exposed to both vertically and horizontally polarized fields on each of the four sides.

8.4.4. TEST SETUP

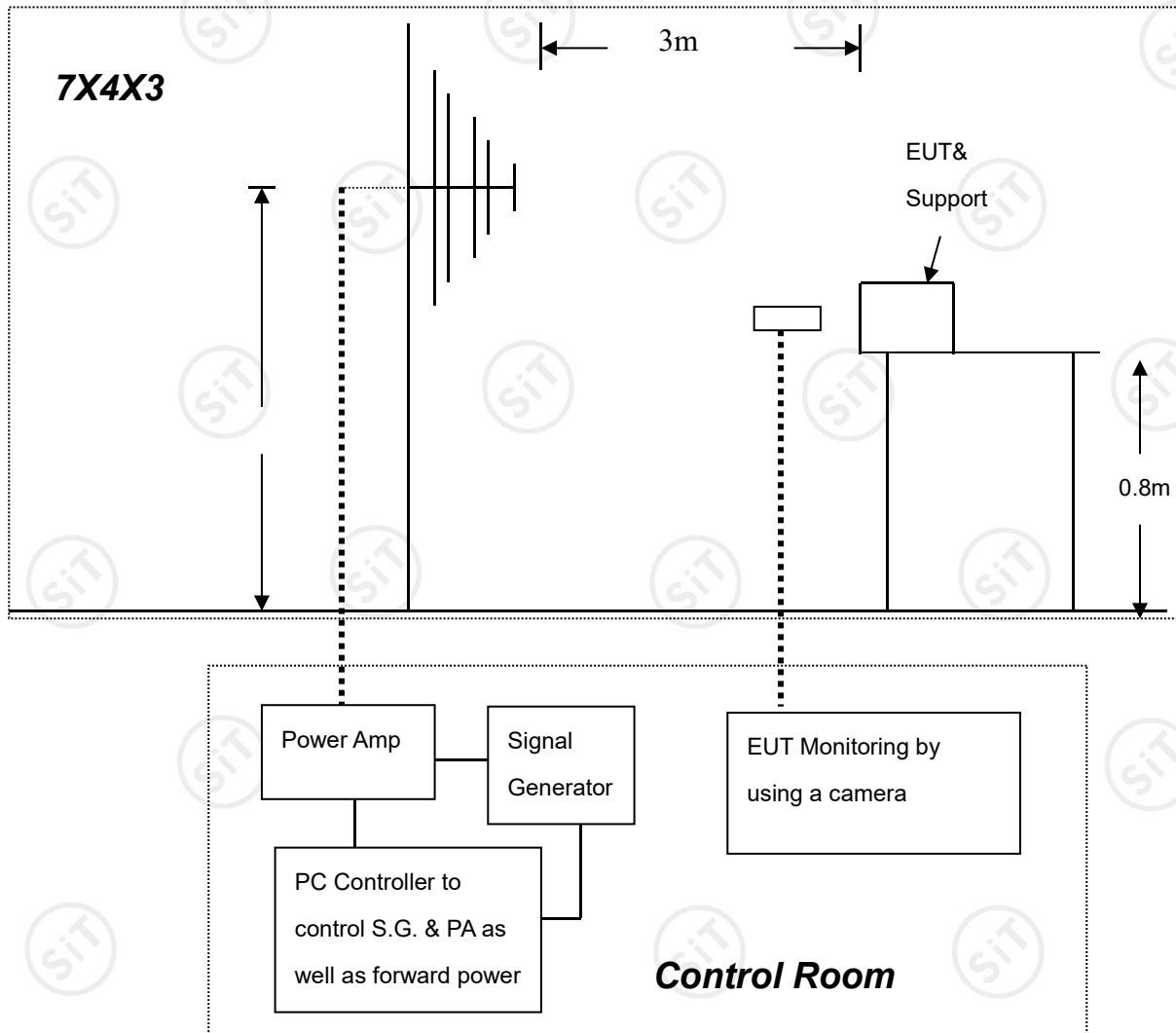

For the actual test configuration, please refer to the related item.

NOTE:

TABLETOP EQUIPMENT

The EUT installed in a representative system as described in section 7 of EN IEC 61000-4-3 was placed on a non-conductive table 0.8 meters in height. The system under test was connected to the power and signal wire according to relevant installation instructions.

FLOOR STANDING EQUIPMENT

The EUT installed in a representative system as described in section 7 of IEC IEC 61000-4-3 was placed on a non-conductive wood support 0.1 meters in height. The system under test was connected to the power and signal wire according to relevant installation instructions.

8.4.5. TEST RESULTS

Temperature:	25°C	Humidity	55% RH
Pressure	996mbar	Test result	Pass
Test mode	Discharging	Test By	DebeYu

Frequency (MHz)	Polarity	Position	Field Strength (V/m)	Observation	Result
80 ~ 1000	V&H	Front	3	Note	PASS
80 ~ 1000	V&H	Rear	3	Note	PASS
80 ~ 1000	V&H	Left	3	Note	PASS
80 ~ 1000	V&H	Right	3	Note	PASS

NOTE: 1. There was no change compared with the initial operation during the test.

8.5. ELECTRICAL FAST TRANSIENT (EFT)

8.5.1. TEST SPECIFICATION

Basic Standard:	EN 61000-4-4
Test Voltage:	Power Line: 1 kV Signal/Control Line: 0.5 kV
Polarity:	Positive & Negative
Impulse Frequency:	5 kHz
Impulse Wave-shape:	5/50 ns
Burst Duration:	15 ms
Burst Period:	300 ms
Test Duration:	Not less than 1 min.
Performance criterion:	B

8.5.2. TEST INSTRUMENT

Immunity Shield Room				
Name of Equipment	Manufacturer	Model	Serial Number	Calibration Due
EMC PARTNER TRANSIENT 2000	EMC PARTNER	TRA2000	881	09/09/2024

NOTE: 1. The calibration interval of the above test instruments is 12 months and the calibrations are traceable to international system unit (SI).

2. N.C.R.= No Calibration required

8.5.3. TEST PROCEDURE

- Both positive and negative polarity discharges were applied.
- The length of the "hot wire" from the coaxial output of the EFT generator to the terminals on the EUT should not exceed 1 meter.
- The duration time of each test sequential was 1 minute.
- The transient/burst waveform was in accordance with EN 61000-4-4, 5/50ns.

8.5.4. TEST SETUP

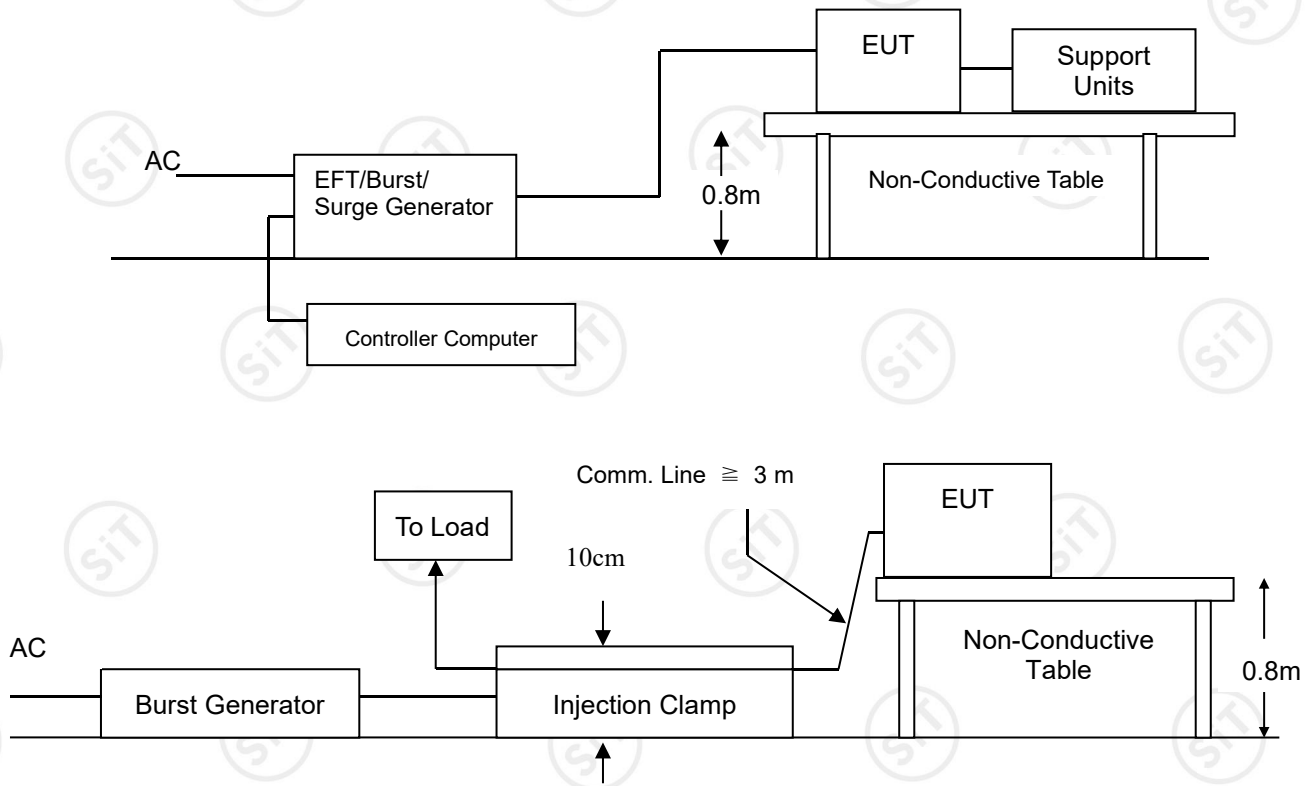

For the actual test configuration, please refer to the related item – Photographs of the Test Configuration.

NOTE:

TABLETOP EQUIPMENT

The configuration consisted of a wooden table (0.8m high) standing on the Ground Reference Plane. The GRP consisted of a sheet of aluminum (at least 0.25mm thick and 2.5m square) connected to the protective grounding system. A minimum distance of 0.5m was provided between the EUT and the walls of the laboratory or any other metallic structure.

FLOOR STANDING EQUIPMENT

The EUT installed in a representative system as described in section 7 of IEC 61000-4-4 and its cables, were isolated from the Ground Reference Plane by an insulating support that is 0.1-meter thick. The GRP consisted of a sheet of aluminum (at least 0.25mm thick and 2.5m square) connected to the protective grounding system.

8.5.5. TEST RESULTS

Temperature:	25°C	Humidity	55% RH
Pressure	996mbar	Test result	N/A
Test mode	Discharging	Test By	DebeYu

Test Point	Polarity	Test Level (kV)	Performance Criterion	Observation	Result
L 1	+/-	1	B	Note <input type="checkbox"/> 1 <input type="checkbox"/> 2	N/A
L 2	+/-	1	B	Note <input type="checkbox"/> 1 <input type="checkbox"/> 2	N/A
L 1-L 2	+/-	1	B	Note <input type="checkbox"/> 1 <input type="checkbox"/> 2	N/A
PE	+/-	1	B	Note <input type="checkbox"/> 1 <input type="checkbox"/> 2	N/A
L – PE	+/-	1	B	Note <input type="checkbox"/> 1 <input type="checkbox"/> 2	N/A
N – PE	+/-	1	B	Note <input type="checkbox"/> 1 <input checked="" type="checkbox"/> 2	N/A
L – N – PE	+/-	1	B	Note <input type="checkbox"/> 1 <input checked="" type="checkbox"/> 2	N/A
RJ45 UTP cable	--	--	--	Note <input type="checkbox"/> 1 <input type="checkbox"/> 2	N/A

NOTE: 1. There was no change compared with initial operation during the test.
 2. The loss of function of the EUT during the test and it was recovered by itself operation after the test.

8.6. SURGE IMMUNITY TEST

8.6.1. TEST SPECIFICATION

Basic Standard:	EN 61000-4-5
Wave-Shape:	Combination Wave 1.2/50 us Open Circuit Voltage 8/20 us Short Circuit Current
Test Voltage:	Power line ~ line to line: 1 kV; line to ground: 2kV Telecommunication line: 1 kV;
Surge Input/Output:	Power Line: L1-L2 / L1-PE / L2-PE Telecommunication line: T-Ground / R-Ground
Generator Source Impedance:	2 ohm between networks 12 ohm between network and ground
Polarity:	Positive/Negative
Phase Angle:	0 /90 /180 /270
Pulse Repetition Rate:	1 time / min. (maximum)
Number of Tests:	5 positive and 5 negative at selected points
Performance Criterion:	B

8.6.2. TEST INSTRUMENT

Immunity Shield Room				
Name of Equipment	Manufacturer	Model	Serial Number	Calibration Due
EMC PARTNER TRANSIENT 2000	EMC PARTNER	TRA2000	881	09/09/2024

NOTE: 1. The calibration interval of the above test instruments is 12 months and the calibrations are traceable to international system unit (SI).
2. N.C.R.= No Calibration required

8.6.3. TEST PROCEDURE

a) For EUT power supply:

The surge is applied to the EUT power supply terminals via the capacitive coupling network. Decoupling networks are required in order to avoid possible adverse effects on equipment not under test that may be powered by the same lines, and to provide sufficient decoupling impedance to the surge wave. The power cord between the EUT and the coupling/decoupling networks was shorter than 2 meters in length.

b) For test applied to unshielded un-symmetrically operated interconnection lines of EUT:

The surge was applied to the lines via the capacitive coupling. The coupling / decoupling networks didn't influence the specified functional conditions of the EUT. The interconnection line between the EUT and the coupling/decoupling networks was shorter than 2 meters in length.

c) For test applied to unshielded symmetrically operated interconnection / telecommunication lines of EUT:

The surge was applied to the lines via gas arrestors coupling. Test levels below the ignition point of the coupling arrestor were not specified. The interconnection line between the EUT and the coupling/decoupling networks was shorter than 2 meters in length.

8.6.4. TEST SETUP

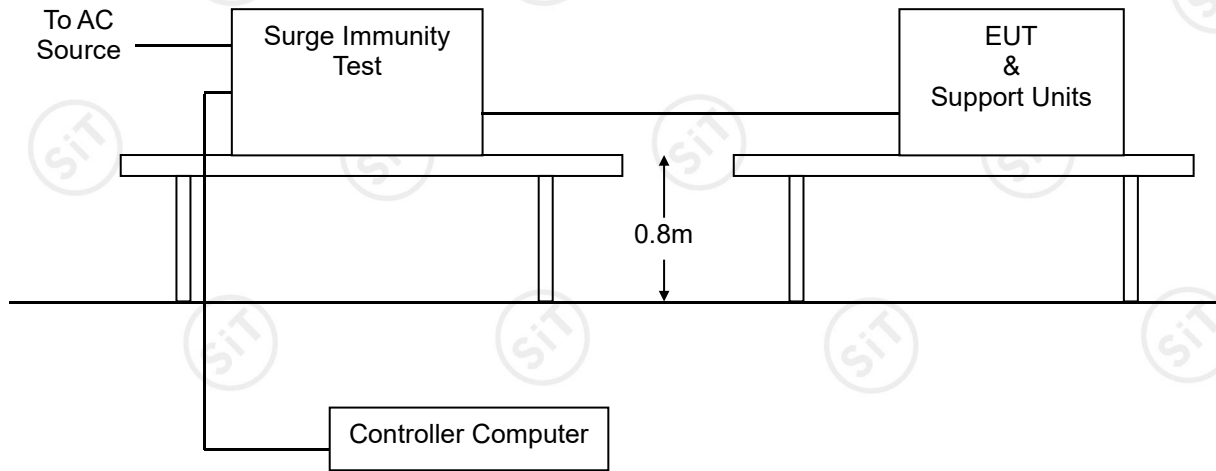

For the actual test configuration, please refer to the related item – Photographs of the Test Configuration.

8.6.5. TEST RESULTS

Temperature:	25°C	Humidity	55% RH
Pressure	996mbar	Test result	N/A
Test mode	Discharging	Test By	DebeYu

Test Point	Polarity	Test Level (kV)	Performance Criterion	Observation	Result
L 1 - L 2	+/-	1	B	Note <input type="checkbox"/> 1 <input type="checkbox"/> 2	N/A
L1 - PE	+/-	2	B	Note <input type="checkbox"/> 1 <input type="checkbox"/> 2	N/A
L2 - PE	+/-	2	B	Note <input type="checkbox"/> 1 <input type="checkbox"/> 2	N/A
R - Ground	--	--	--	Note <input type="checkbox"/> 1 <input type="checkbox"/> 2	N/A
T - Ground	--	--	--	Note <input type="checkbox"/> 1 <input type="checkbox"/> 2	N/A

NOTE: 1. There was no change compared with initial operation during the test.
 2. The loss of function of the EUT during the test and it was recovered by itself operation after the test.

8.7. CONDUCTED RADIO FREQUENCY DISTURBANCES (CS)

8.7.1. TEST SPECIFICATION

Basic Standard:	EN 61000-4-6
Frequency Range:	0.15 MHz ~ 80 MHz
Field Strength:	3 V
Modulation:	1kHz Sine Wave, 80%, AM Modulation
Frequency Step:	1 % of preceding frequency value
Coupled cable:	Power Mains, Shielded
Coupling device:	CDN-M3/2 (3 wires)
Performance criterion:	A

8.7.2. TEST INSTRUMENT

CS Test				
Name of Equipment	Manufacturer	Model	Serial Number	Calibration Due
Signal Generator	Maconi	2022D	119246/003	09/19/2024
Power Amplifier	M2S	A00181-1000	9801-112	09/19/2024
CDN	MEB	M3-8016	003683	09/19/2024

- NOTE:** 1. The calibration interval of the above test instruments is 12 months and the calibrations are traceable to international system unit (SI).
 2. N.C.R.= No Calibration required

8.7.3. TEST PROCEDURE

The EUT shall be tested within its intended operating and climatic conditions.

The test shell performed with the test generator connected to each of the coupling and decoupling devices in turn, while the other non-excited RF input ports of the coupling devices are terminated by a 50-ohm load resistor.

The frequency range was swept from 150 kHz to 80 MHz, using the signal level established during the setting process and with a disturbance signal of 80 % amplitude. The signal was modulated with a 1 kHz sine wave, pausing to adjust the RF signal level or the switch coupling devices as necessary. The sweep rate was 1.5×10^{-3} decades/s. Where the frequency range is swept incrementally, the step size was 1 % of preceding frequency value from 150 kHz to 80 MHz.

The dwell time at each frequency was less than the time necessary for the EUT to be exercised, and able to respond. Sensitive frequencies such as clock frequency(ies) and harmonics or frequencies of dominant interest, was analyzed separately.

Attempts were made to fully exercise the EUT during testing, and to fully interrogate all exercise modes selected for susceptibility.

8.7.4. TEST SETUP

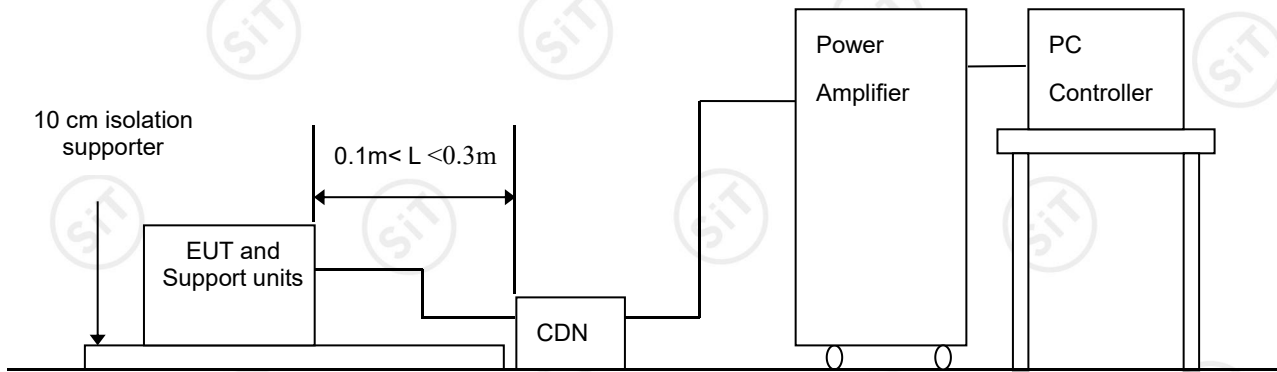

- Note:**
1. The EUT is setup 0.1m above Ground Reference Plane
 2. The CDNS and / or EM clamp used for real test depends on ports and cables configuration of EUT.

For the actual test configuration, please refer to the related item .

NOTE:

TABLE-TOP AND FLOOR-STANDING EQUIPMENT

The equipment to be tested is placed on an insulating support of 0.1 meters height above a ground reference plane. All relevant cables shall be provided with the appropriate coupling and decoupling devices at a distance between 0.1 meters and 0.3 meters from the projected geometry of the EUT on the ground reference plane.

8.7.5. TEST RESULTS

Temperature:	25°C	Humidity	55% RH
Pressure	996mbar	Test result	N/A
Test mode	Discharging	Test By	DebeYu

Frequency Band (MHz)	Field Strength (Vrms)	Injected Position	Injection Method	Performance Criterion	Observation	Result
0.15 ~ 80	3	AC Mains	CDN-M3	A	Note <input type="checkbox"/> 1 <input type="checkbox"/> 2	N/A
0.15 ~ 80	3	LAN(10m)	--	--	Note <input type="checkbox"/> 1 <input type="checkbox"/> 2	N/A

- NOTE:** 1. There was no change compared with initial operation during the test.
 2. The loss of function of the EUT during the test and it was recovered by itself operation after the test.
 3.N/A means to no applicable.

8.8. POWER FREQUENCY MAGNETIC FIELD

8.8.1. TEST SPECIFICATION

Basic Standard:	EN 61000-4-8
Frequency Range:	50Hz
Field Strength:	1A/m
Observation Time:	5 minutes
Inductance Coil:	Rectangular type, 1mMO6390m
Performance criterion:	A

8.8.2. TEST INSTRUMENT

Immunity Shield Room				
Name of Equipment	Manufacturer	Model	Serial Number	Calibration Due
Power-frequency Magnetic field	SCHAFFNER	CCN 1000-1	72046	09/17/2024
Induction Coil Interface	SCHAFFNER	INA2141	6003	09/17/2024

NOTE: 1. The calibration interval of the above test instruments is 12 months and the calibrations are traceable to international system unit (SI).

2. N.C.R.= No Calibration required

8.8.3. TEST PROCEDURE

- a. The equipment is configured and connected to satisfy its functional requirements. It shall be placed on the GRP with the interposition of a 0.1m-thick insulating support.
- b. The equipment cabinets shall be connected to the safety earth directly on the GRP via the earth terminal of the EUT.
- c. The power supply, input and output circuits shall be connected to the sources of power supply, control and signal.
- d. The cables supplied or recommended by the equipment manufacturer shall be used. 1 meter of all cables used shall be exposed to the magnetic field.

8.8.4. TEST SETUP

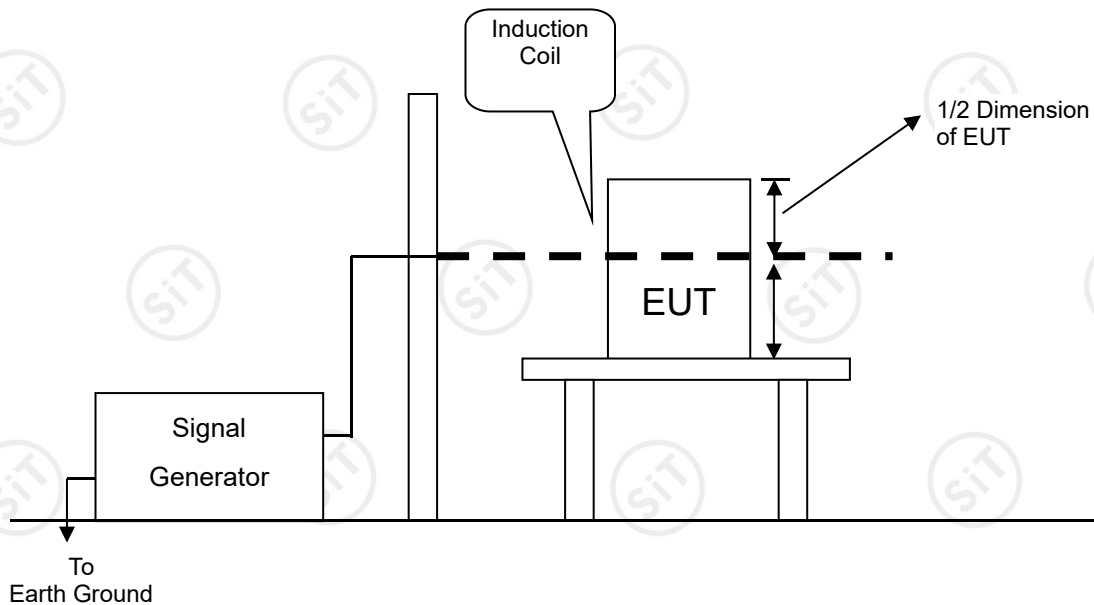

For the actual test configuration, please refer to the related item .

NOTE:

TABLETOP EQUIPMENT

The equipment shall be subjected to the test magnetic field by using the induction coil of standard dimension (1 m x 1 m). The induction coil shall then be rotated by 90 degrees in order to expose the EUT to the test field with different orientations.

FLOOR-STANDING EQUIPMENT

The equipment shall be subjected to the test magnetic field by using induction coils of suitable dimensions. The test shall be repeated by moving and shifting the induction coils, in order to test the whole volume of the EUT for each orthogonal direction. The test shall be repeated with the coil shifted to different positions along the side of the EUT, in steps corresponding to 50 % of the shortest side of the coil. The induction coil shall then be rotated by 90 degrees in order to expose the EUT to the test field with different orientations.

8.8.5. TEST RESULTS

Temperature:	25°C	Humidity	55% RH
Pressure	996mbar	Test result	N/A
Test mode	Discharging	Test By	DebeYu

DIRECTION	Field Strength (A/m)	Performance Criterion	OBSERVATION	RESULTS
X	1	A	Note <input checked="" type="checkbox"/> 1 <input type="checkbox"/> 2	N/A
Y	1	A	Note <input checked="" type="checkbox"/> 1 <input type="checkbox"/> 2	N/A
Z	1	A	Note <input checked="" type="checkbox"/> 1 <input type="checkbox"/> 2	N/A

NOTE: 1. There was no change compared with initial operation during the test.
 2. The loss of function of the EUT during the test and it was recovered by itself operation after the test.

8.9. VOLTAGE DIP & VOLTAGE INTERRUPTIONS

8.9.1. TEST SPECIFICATION

Basic Standard:	EN IEC 61000-4-11
Test duration time:	Minimum three test events in sequence
Interval between event:	Minimum 10 seconds
Phase Angle:	0 /45 / 90/ 135/ 180/ 225/ 270/ 315/ 360
Test cycle:	3 times
Performance criterion:	B,C

8.9.2. TEST INSTRUMENT

Immunity shielded room				
Name of Equipment	Manufacturer	Model	Serial Number	Calibration Due
EMC PARTNER TRANSIENT 2000	EMC PARTNER	TRA2000	881	09/09/2024

NOTE: 1. The calibration interval of the above test instruments is 12 months and the calibrations are traceable to international system unit (SI).
2. N.C.R.= No Calibration required

8.9.3. TEST PROCEDURE

1. The EUT and support units were located on a wooden table, 0.8 m away from ground floor.
2. Setting the parameter of tests and then perform the test software of test simulator.
3. Conditions changes to occur at 0 degree crossover point of the voltage waveform.
4. Recording the test result in test record form.

8.9.4. TEST SETUP

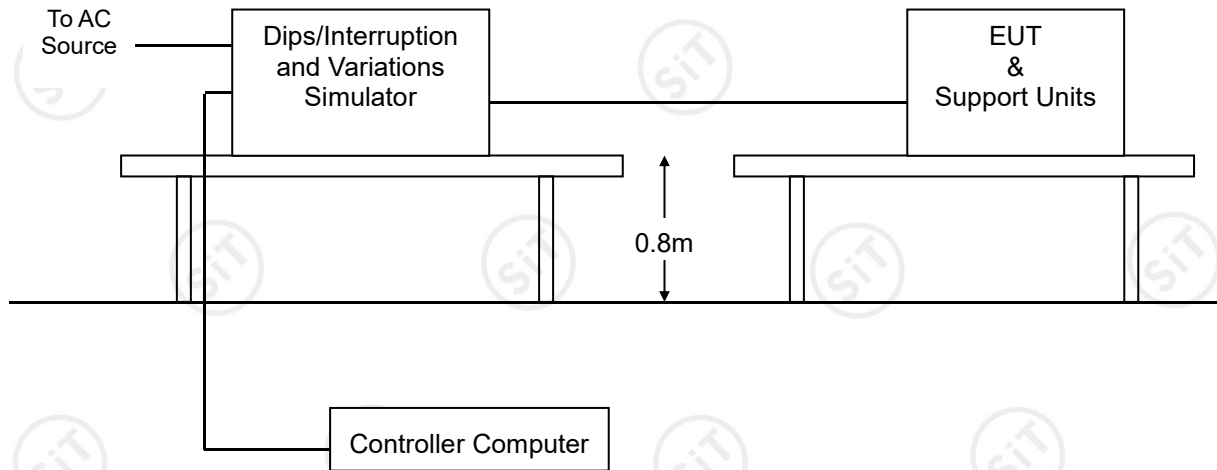

For the actual test configuration, please refer to the related item – Photographs of the Test Configuration.

8.9.5. TEST RESULTS

Temperature:	25°C	Humidity	55% RH
Pressure	996mbar	Test result	N/A
Test mode	Discharging	Test By	DebeYu

Voltage (% Reduction)	Duration (Period)	Performance Criterion	Observation	Test Result
98	0.5	<input type="checkbox"/> A <input checked="" type="checkbox"/> B <input type="checkbox"/> C	Note <input type="checkbox"/> 1 <input type="checkbox"/> 2 <input type="checkbox"/> 3	N/A
30	25	<input type="checkbox"/> A <input type="checkbox"/> B <input type="checkbox"/> C	Note <input type="checkbox"/> 1 <input type="checkbox"/> 2 <input type="checkbox"/> 3	N/A
100	250	<input type="checkbox"/> A <input type="checkbox"/> B <input type="checkbox"/> C	Note <input type="checkbox"/> 1 <input type="checkbox"/> 2 <input type="checkbox"/> 3	N/A

- NOTE:** 1. There was no change compared with initial operation during and after the test.
 No unintentional response was found during the test.
 2. The function stopped during the test, but can be recoverable by itself operation after the test.
 3. The function stopped during the test, but can be recoverable manually after the test.

9 PHOTOGRAPHS OF THE TEST CONFIGURATION

RADIATED EMISSION TEST

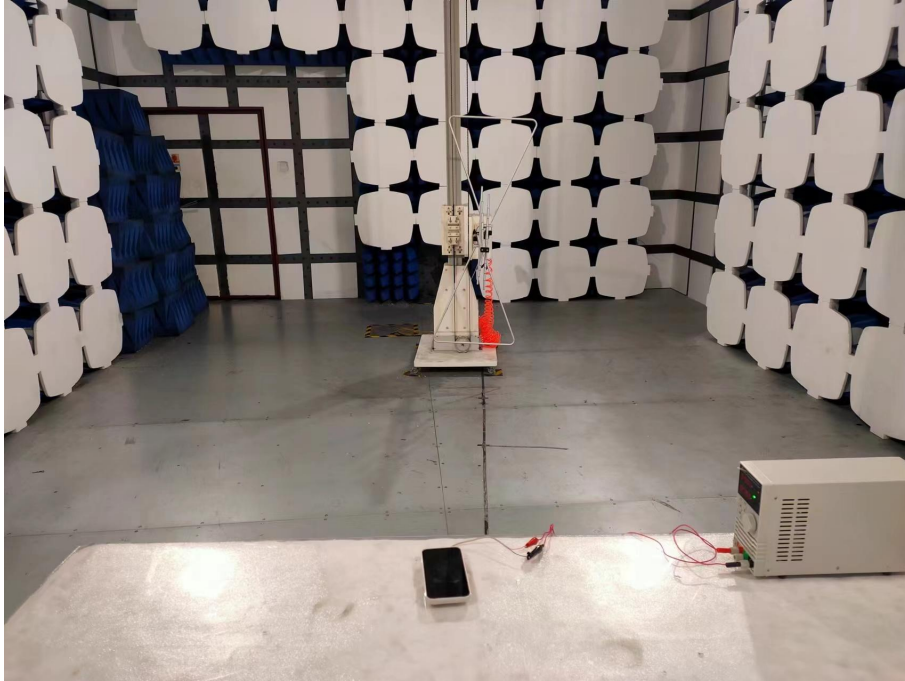

10 PHOTOGRAPHS OF EUT

Appearance photograph of EUT



Appearance photograph of EUT

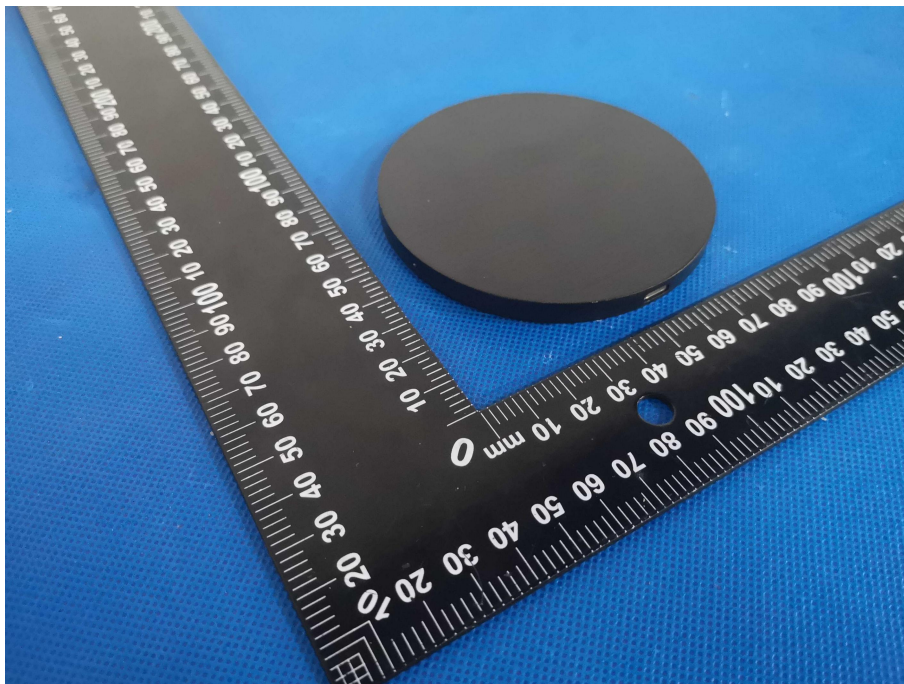

Appearance photograph of EUT

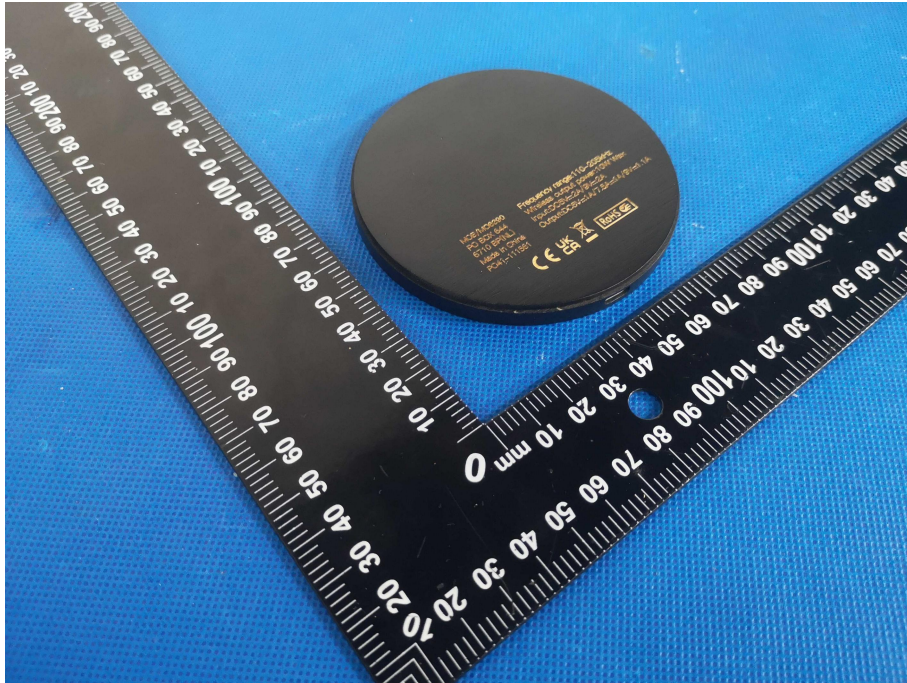

Appearance photograph of EUT

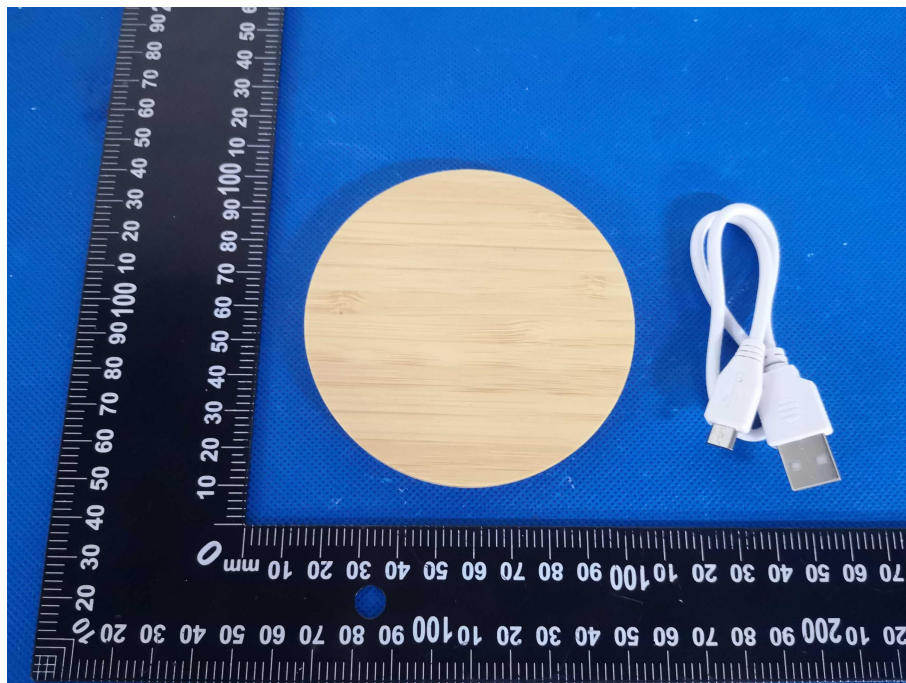

Appearance photograph of EUT

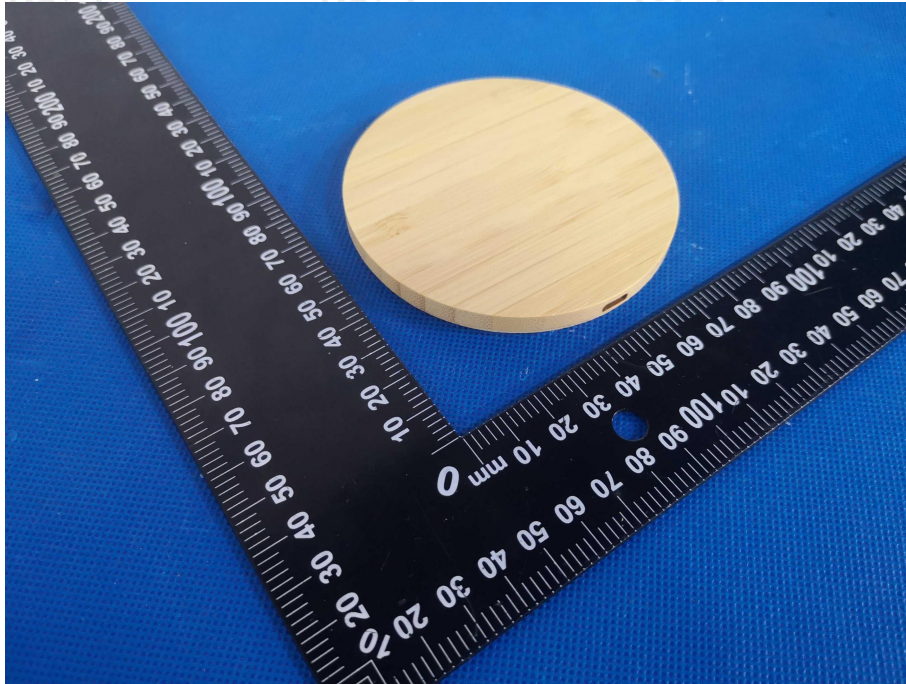

Appearance photograph of EUT

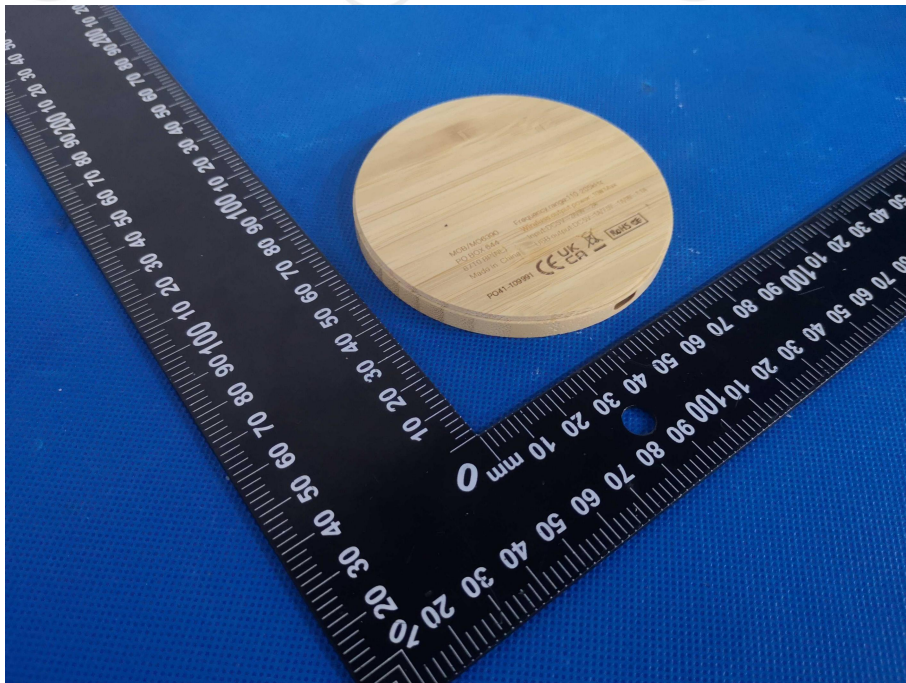

Appearance photograph of EUT

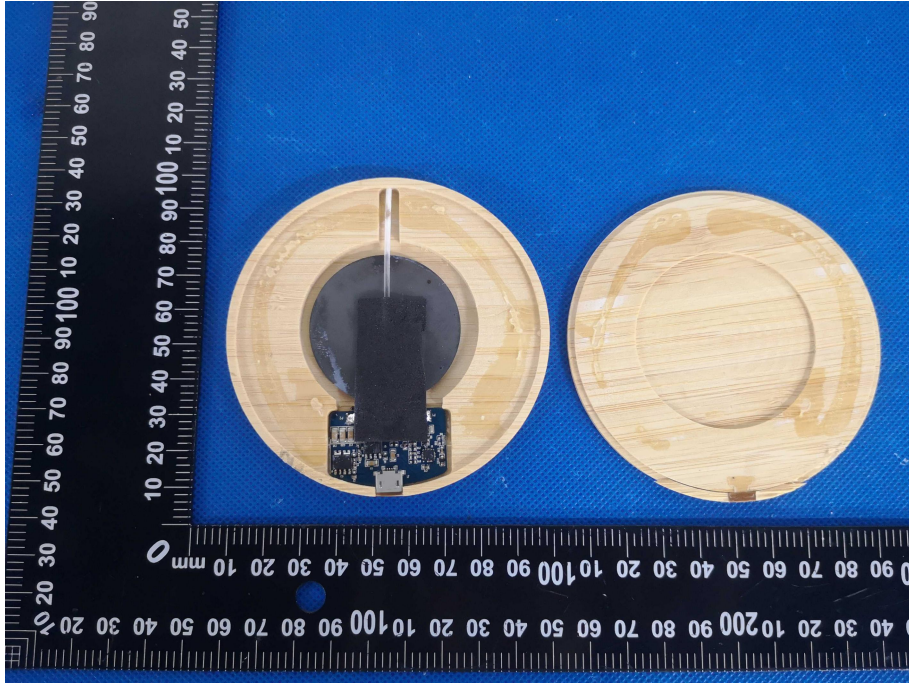

Appearance photograph of EUT

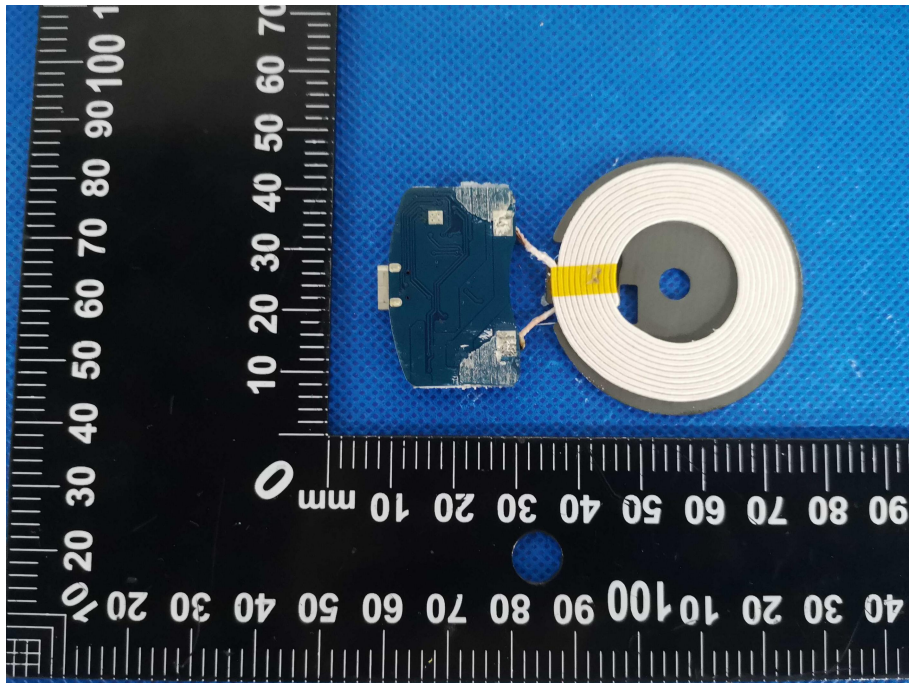

Appearance photograph of EUT

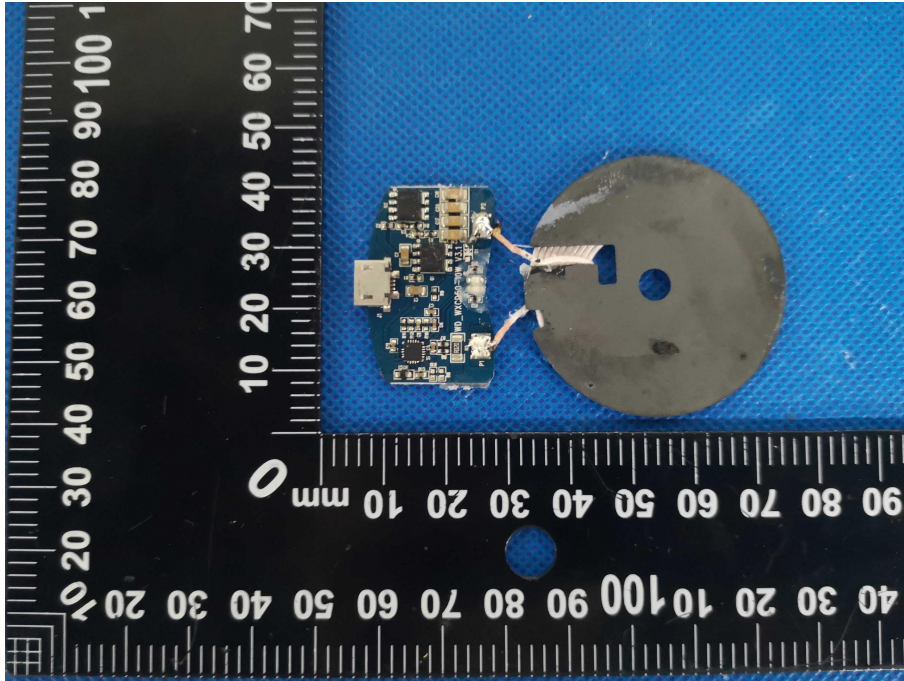

*****END OF REPORT*****